

Atlas TTC305



Fully Automatic, Heavy Duty Truck Tire Changer



Atlas Automotive Equipment
www.atlasautoequipment.com
(866) 898-2604

PRINTING CHARACTERS AND SYMBOLS

Throughout this manual, the following symbols and printing characters are used to facilitate reading:

	Indicates the operations which need proper care
	Indicates prohibition
	Indicates a possibility of danger for the operators
BOLD TYPE	Important information

	WARNING: before operating the machine, read the manual carefully for all proper operations and better functioning.
---	---

CONTENTS

1	INTRODUCTION	4
	1.1 - INTRODUCTION	4
	1.2 MACHINE IDENTIFICATION DATA	4
	1.3 MANUAL KEEPING	4
2	GENERAL INFORMATION	5
	2.1 INTENDED USE	5
	2.2 GENERAL SAFETY PRECAUTIONS	5
	2.3 SAFETY DEVICES	5
	2.4 PRODUCT DESCRIPTION	6
	2.5 TECHNICAL SPECIFICATION	6
	2.6 IDENTIFYING WARNING SIGNS	7
3	TRANSPORTATION AND UNPACKING	8
	3.1 TRANSPORTATION	8
	3.2 UNPACKING	8
4	INSTALLATION	9
	4.1 INSTALLATION SPACE REQUIRED	9
	4.2 WORKPLACE REQUIRED	9
	4.3 FOUNDATION REQUIREMENT	9
	4.4 ELECTRIC HOOK UP	10
5	OPERATION	11
	5.1 CONTROLS	11
	5.2 CORRECT OPERATION CHECKS	12
	5.3 LOCKING THE WHEEL	13
	5.4 LIGHT-ALLOY RIM LOCKING	14
	5.5 DEMOUNTING TUBELESS TIRES	14
	5.6 MOUNTING TUBELESS TIRES	15
6	ORDINARY MAINTENANCE	16
7	TROUBLE SHOOTING	17
8	MOVING, STORING AND SCRAPPING	18
	8.1 MOVING THE MACHINE	18
	8.2 STORING	18
	8.3 SCRAPPING A MACHINE	18
9	OPTIONAL ACCESSORIES	19
10	HYDRAULIC SCHEME AND ELECTRIC DIAGRAM	20
11	PARTS LIST	22

CHAPTER 1 – INTRODUCTION

1.1 INTRODUCTION

Thank you for purchasing a product from the line of truck tire changers. The machine has been manufactured in accordance with the very best quality principles. Follow the simple instructions provided in this manual to ensure the correct operation and long life of the machine. Read the entire manual thoroughly and make sure you understand it.

1.2 MACHINE IDENTIFICATION DATA

A complete description of the “Tire Changer Model” and the “Serial number” will make it easier for our technical assistance to provide service and will facilitate delivery of any required spare parts. For clarity and convenience, we have inserted the data of your machine in the box below. If there is any discrepancy between the data provided in this manual and that shown on the name plate fixed to the wheel balancer, the latter should be taken as correct.

LOGO		
Type:		
Volt	Amp	Kw
Ph	Hz	
Year of manufacturing:		

1.3 MANUAL KEEPING

For a proper use of this manual, the following is recommended:

- Keep the manual near the lift, in an easily accessible place.
- Keep the manual in an area protected from the damp.
- Use this manual properly without damaging it.
- Any use of the machine made by operators who are not familiar with the instructions and procedures contained herein shall be forbidden.

This manual is an integral part of the manual: it shall be given to the new owner if and when the machine is resold.

	The illustrations have been made out of prototypes pictures. It is therefore possible that some parts or components of standard production differ from those represented in the pictures.
---	--

TO THE READER

Every effort has been made to ensure that the information contained in this manual is correct, complete and up-to-date. The manufacturer is not liable for any mistakes made when drawing up this manual and reserves the right to make any changes due the development of the product, at any time

CHAPTER 2 – GENERAL INFORMATION

2.1 INTENDED USE

- This tire changer has been designed and manufactured exclusively to be put on a can for removing and mounting truck, bus and commercial van tires from/onto rim bores from 8" to 23" and a tire at maximum diameter of 55".
- In particular the manufacturer cannot be held responsible for any damage caused through the use of this tire changer for purposes other than those specified in this manual, and therefore inappropriate, incorrect and unreasonable.

2.2 GENERAL SAFETY PRECAUTIONS

- The machine should only be used by duly authorized and trained personnel.
- The machine should not be used for purposes other than those described in the instruction manual.
- Under no way should the machine be modified except for those modifications made explicitly by the manufacturer.
- Never remove the safety devices. Any work on the machine should only be carried out by specialist personnel.
- Any tampering or modification to the equipment carried out without the manufacturer's prior authorization will free him from all responsibility for damage caused directly or indirectly by the above actions.
- Removing or tampering with safety devices immediately invalidates the guarantee.
- The tire changer comes complete with instruction and warning transfers which are designed to be long-lasting. If they should for any reason be damaged or destroyed, please ask immediately for replacements from the manufacturer.
- The machine operator should avoid wearing clothes with flapping edges. Make sure that unauthorized personnel do not approach the machine during the work cycle.

2.3 SAFETY DEVICES

The tire changer has a number of safety devices designed to guarantee the upmost safety:

- **Check valve on the spindle opening hydraulic line** (inside the swivel connector, see fig. B/1). This prevents the wheel from falling from the spindle if the hydraulic line is accidentally broken.
- **Pressure relief valve set at 130 bar \pm 10%** (see fig. B/2). This limits the pressure in the hydraulic line and ensures correct operation of the plant.
- **Pump motor overload cut-off** (inside the electric enclosure). This cut prevents the motor from burning out if it overheats.
- **Check valve on the chuck arm lifting hydraulic line.** It prevents the chuck arm from descending when any accidental break occurs in the hydraulic line. .

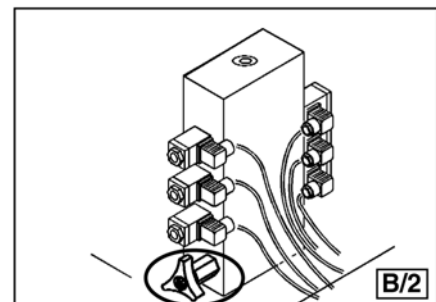
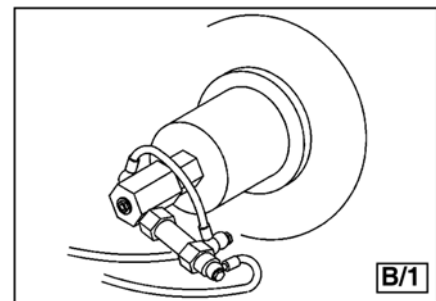

2.4 PRODUCT DESCRIPTION

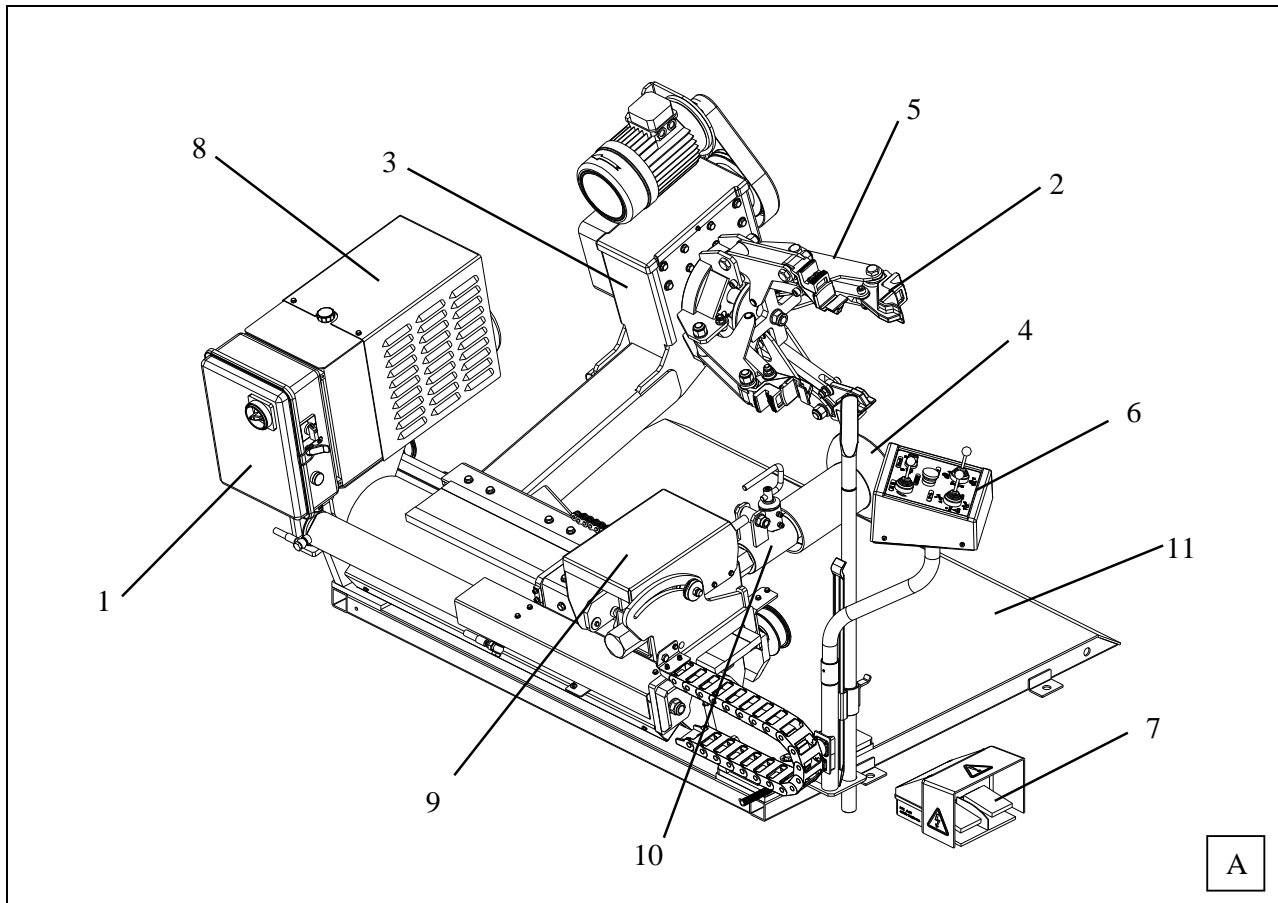

- | | |
|-------------------------|-------------------------|
| 1. Electric system | 7. Foot pedal |
| 2. Jaw | 8. Hydraulic power unit |
| 3. Chuck arm | 9. Carriage |
| 4. Tool roller | 10. Tool holder arm |
| 5. Self-centering chuck | 11. Frame plate |
| 6. Control unit | |

2.5 TECHNICAL SPECIFICATION

Pump motor	2 HP 220V +/- 5% (209-231volts) 1 phase. A 30 amp breaker is required.
Handles rim from	13" – 26"
Max. tire diameter	55"
Max. tire width	30 1/2"
Max. wheel weight	838 LBS
Gross weight	1490
Noise level in working condition	< 70 dB (A)

CHAPTER 3 – TRANSPORTATION AND UNPACKING

3.1 TRANSPORTATION

- The machine must be transported in its original packaging and kept in the position shown on the package itself.
- The packaged machine may be moved by means of a fork lift truck of suitable capacity. Insert the forks at the points shown in fig. A/2.

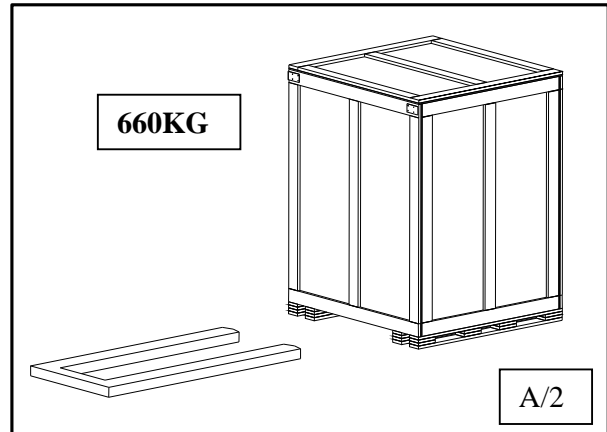

3.2 UNPACKING

- Remove the packing materials.
- After removing the packaging from the machine, make sure to check it without any damage.



If in doubt do not use the machine and contact your retailer.

CHAPTER 4 – INSTALLATION

4.1 INSTALLATION SPACE REQUIRED



When choosing the place of installation, make sure that it complies with current safety at work regulations.

- The machine must be located on a flat floor of solid construction, preferably concrete. If the floor is uneven or broken, the machine will be not stable and the platform roller cannot move freely.
- If the machine is installed outside it must be protected by a lean-to.
- The following work environment conditions are applicable:
 - Relative humidity from 30-95% without condensation;
 - Temperature from 32-130°F.

4.2 WORKPLACE REQUIRED

- Maximum machine space requirements are with a minimum distance from walls as shown in the diagram (see fig. B/5).

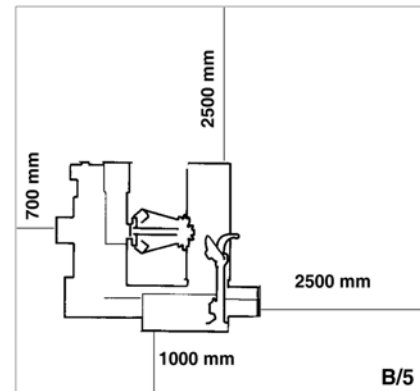

These measurements are also the tire changer working area. Persons other than specially trained and authorized operators are extremely forbidden to enter this area.

- Position the tire changer with the tool holder arm (10/fig. A) lowered all the way and the jaws (2/fig. A) closed.

4.3 FOUNDATION REQUIREMENT

The tire changer should be installed on a leveled concrete floor at least 20cm thick with a minimum concrete quality of B25 in accordance with DIN 1045 requirements (foundations).

If a floor of this type is not available on site, fastening points of the specified concrete quality are acceptable.

- Surface, on which the tire changer is to be installed, must be flat and well leveled in all directions..
- Inclination up to 0.25% relative to the horizontal can be compensated using suitable shims, wedges or the alike.

4.4 ELECTRIC HOOK UP

	Any electric connection job must be carried out by professionally qualified personnel.
---	---

- Check to make sure the characteristics of your systems correspond to those required by the machine. The supply voltage (and main frequency) is given on the machine nameplate. It cannot be changed.
- Connect the machine to the generator unit. If the machine does not include the electric plug, the user must set one, which must conform to the voltage of the machine, in compliance with the regulations in force.
- The machine should not be started up without proper grounding.

	It is absolutely essential that: The current intake is adequately protected against over currents with fuses or automatic magneto-thermic switch with rated value as shown in the table.
---	---

Power supply	Rated current	
	Fuse	Switch
220V/230V – 3ph – 50/60Hz	25A AM	25A
380V/440V – 3ph – 50/60Hz	16A AM	16A

- Open the control panel;
- Switch the breaker on (fig. B/3)
- Switch on the electric panel (fig. B/7) and check that the gearbox motor rotation corresponds to the indicating arrow (fig. B/6).
- If not, switch two wires in the plug.

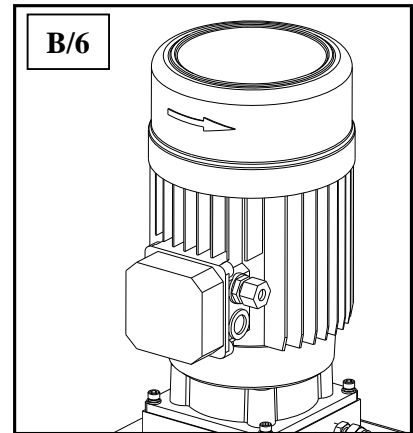
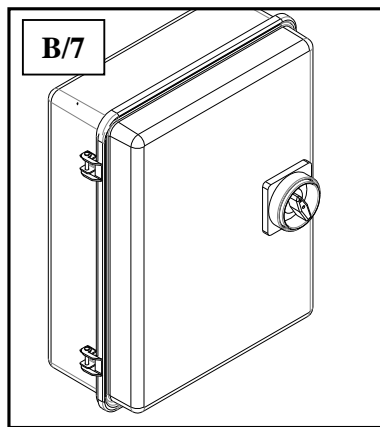
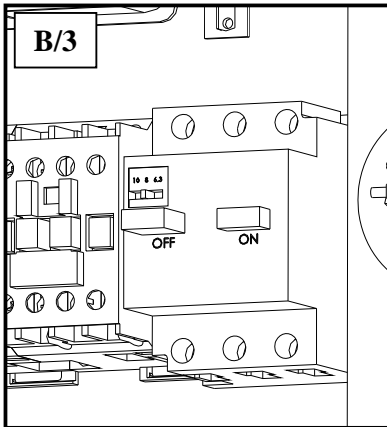

CHAPTER 5 – OPERATION

5.1 CONTROLS

The control unit (fig. C) can be operated as follows:

	Do not permit the electric control panel to get wet!
---	---

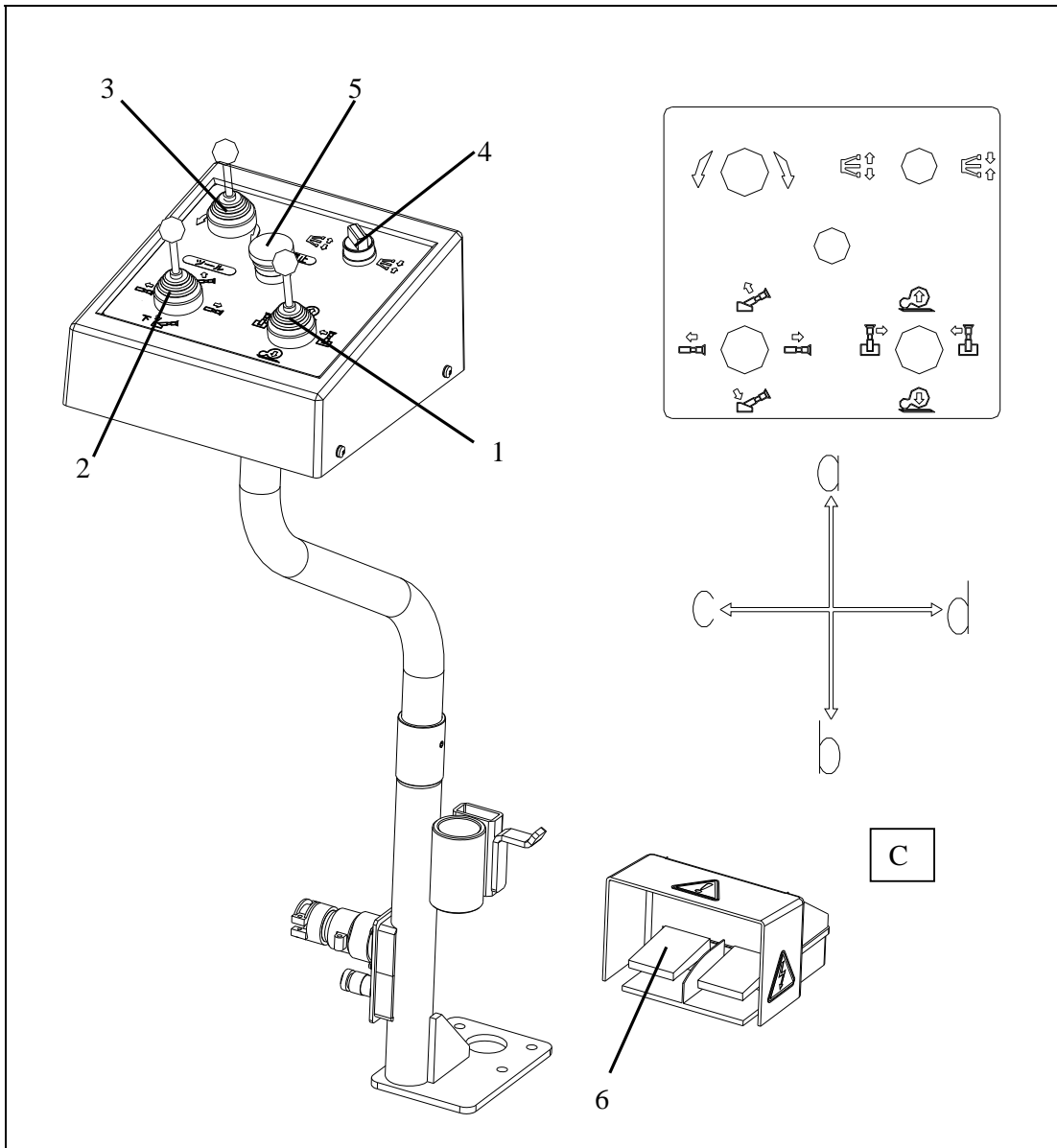

➤ **Joystick 1 (1/fig. C):**

- Move it to position [a] to raise the chuck arm (3/fig. A).
- Move it to position [b] to lower the chuck arm.
- Move it to position [c] to moves the carriage (9/fig. A) and the chuck arm towards each other.
- Move it to position [d] moves the carriage and the chuck arm away from each other.

➤ **Joystick 2 (2/fig. C):**

- Move it to position [a] to raise the tool holder arm (10/fig. A) out of working position.
- Move it to position [b] to lower the tool holder arm to the working position.
- Move it to position [c] to retract the tool roller (4/fig. A) back.
- Move it to position [d] to extend the tool roller forward.

➤ **Joystick 3 (3/fig. C):**

- Move it to position [c] or [d] to rotate the self-centering chuck (5/fig. A) in the same direction as shown by the arrows on the control panel.

This operation can be carried out by depressing the foot pedal.

➤ **Chuck switch (4/fig. C):**

- Move it to position [c] to open the self-centering chuck.
- Move it to position [d] to close the self-centering chuck.

➤ **Emergency button (5/fig. C):**



- For emergencies, press it to cut out the tire changer power supply.

➤ **Foot pedal (6/fig. C):**

- When pressed on the left or right side rotates the self-centering chuck in the same direction as shown by the arrows placed on the foot pedal.

This operation can be carried out by operating the joystick 3.

5.2 CORRECT OPERATION CHECKS

	Before using the tire changer, make sure that it is positioned correctly on the ground.
	Do not move your face close to the tool when you raise it.
	When the chuck arm is lowered, there is always a potential for crushing anything in its movement range. Always work from position given in the instructions keep well out of working range of the various moving arms.

Before use the tire changer, a number of checks should be made to ensure it works correctly.

Operate the joysticks and the switches described in the chapter 5.1 and be sure that every control works correctly.

Check to be certain the hydraulic circuit is working correctly:

- Move the chuck switch (4/fig. C) towards the top until the chuck is fully extended.
- Hold the switch lever in this position (top) and check if the pressure shown on the gauge on the swivel fitting is 130bar \pm 10%. **DO NOT USE THE MACHINES IF THE PRESSURE SHOWN IS NOT AS INDICATED HERE AND THEN CALL FOR THE SERVICE.**

5.3 LOCKING THE WHEEL

	<p>When the chuck arm is lowered, there is always a potential for crushing anything in its movement range. Always work from position given in the instructions keep well out of working range of the various moving parts.</p>
---	--

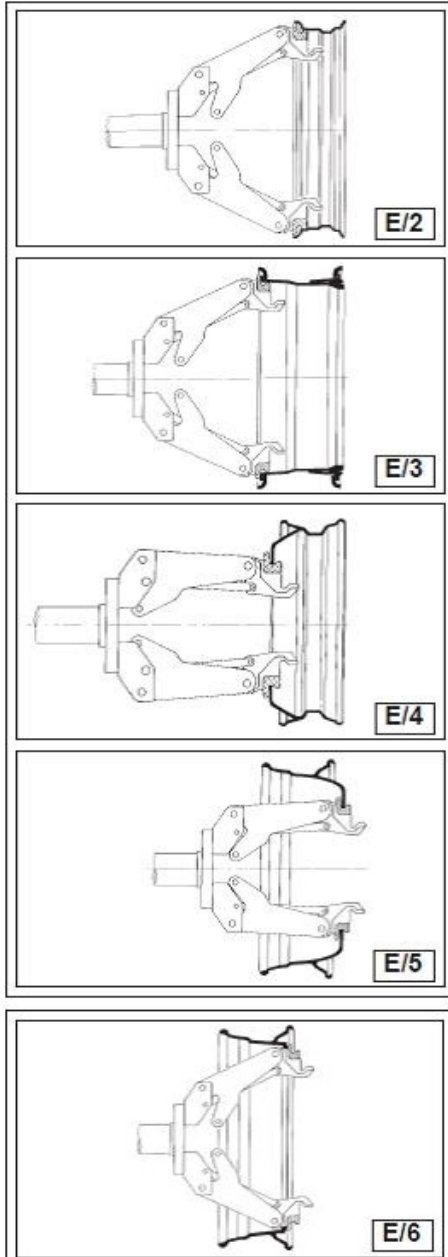



	<p>In locking the wheel, make sure that clamps are properly positioned on the rim, so as to prevent the tire from falling.</p>
---	---

- Operate the joystick 2 (2/fig. C) to raise the tool holder arm (10/fig. A) out of the working position.

	<p>This operation can be extremely dangerous. Do it manually only if you are certain you can keep the wheel balanced. For large and heavy tires an adequate lifting device must be used.</p>
---	---

- Operate the joystick 1 (1/fig. C) to raise or lower the chuck arm until the chuck is centered with the rim.
- With the jaws (2/fig. A) are closed, bring the wheel up to the chuck.
- Operate the chuck switch (4/fig. C) to open the chuck and lock the rim internally in the best position based on the type of the rim according to figs E/1-E/2-E/3-E/4-E/5 and E/6.

	<p>Always remember that the safest locking is on the central FLANGE.</p> <p>For rims with channel, clamp the wheel so that the channel is near the outside of the rim (fig. E/1).</p>
---	---

	<p>Do not leave the work area with a wheel clamped on the tire changer and lifted up from the floor.</p>
---	---

5.4 LIGHT-ALLOY RIM LOCKING

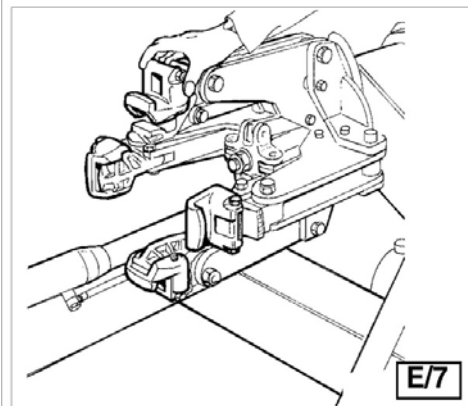

The jaw protection kit CC-F100100 can be available upon request, are specially designed for operating on light alloy rims without damaging them.

The protections are to be inserted (bayonet-like mounting) into the clamp support of the self-centering chuck (see fig. E/7).

Lock the rim as illustrated in fig. E/8. The specially-made pliers YC8-F200000 should be attached to the outside edge of the alloy rim at the highest point.

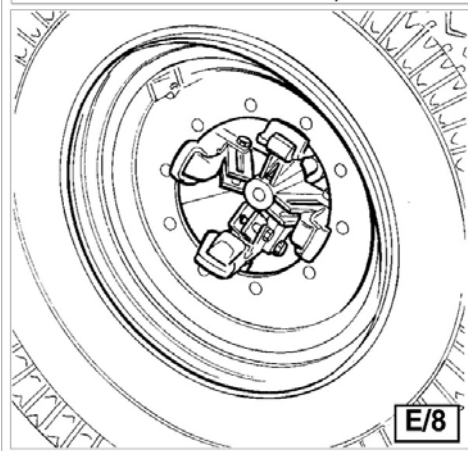

5.5 DEMOUNTING TUBELESS TIRES

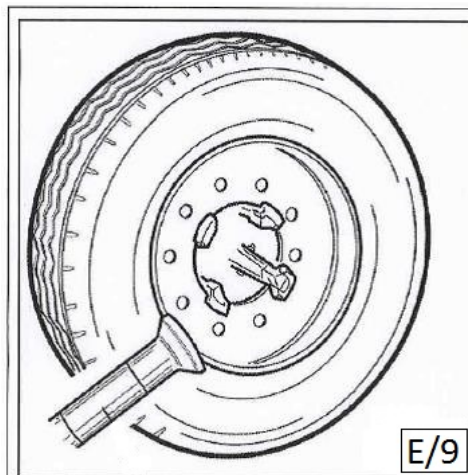

- Before removing the tire, lubricate the beads carefully to protect them from being possible damages to facilitate the removing operations.
- Lock the wheel on the self-centering chuck, as previously described, and ensure that the tire is deflated.



Always check to be certain that the arm is corrected hooked to the carriage.



A mechanical lifting device must be used when handling wheels weighing more than 110kg.

- Lower the tool-holder arm (10/fig. A) into its working position.
- Operate the joystick to move the wheel until the roller just touches the edge of the rim as shown in the figure E/9.
- Rotate the wheel and at the same time advance the roller with small movements forward according to the profile of the rim (ref. fig. E/10).

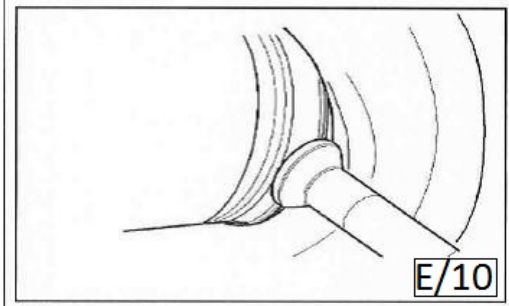

- Continue until the first bead is fully detached. To facilitate this operation, lubricate the bead and the edge of the rim with tire lubricant whilst the wheel is rotated.



To avoid all risks, rotate the wheel clockwise when operating on the outside plane and anticlockwise when operating on the inside plane.

- Bring the tool-holder arm (10/fig. A) away from the rim. Raise the tool holder arm to its non-working position, shift it and re-hook it in its second work position.



Do not keep your hands on the tool when setting it in working position so as to avoid any possible crushing between the tire and the tool.

- Repeat the operation previously described until the second bead is completely detached.
- Go on pushing the tire until the rim comes completely out.

5.6 MOUNTING TUBELESS TIRES

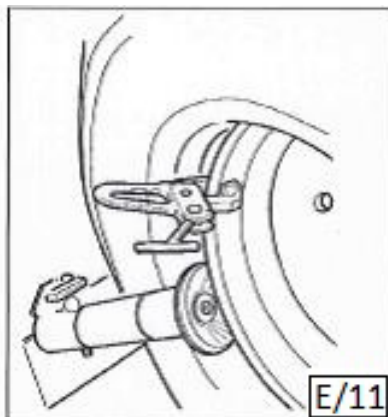

- Make sure that the rim is locked on the self-centering chuck.
- Lubricate the beads and rim carefully to facilitate the mounting operations.
- Fix the pliers at the outer rim edges at its highest point. Make sure the clip is firmly attached to the rim.
- Lower the chuck to allow locking the first bead with the pliers (make sure it at the high point).
- Lift the rim with the tire fixed and turn it anticlockwise about 15-20 cm. The tire will be positioned tilted across the rim.
- Lower the tool-holder arm into its working position.
- Operate the joystick 1 to position the roller against the second

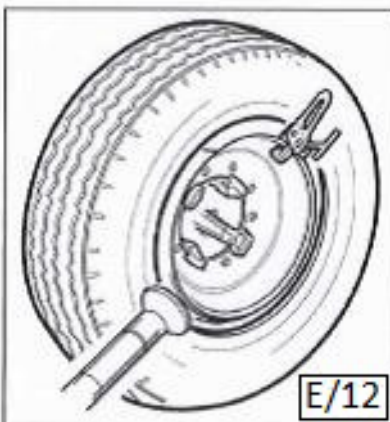

- tire bead and turn the tire until the pliers is at the lowest position. The first bead should be set on the rim at this time.
- Position the roller at a distance of 4-5mm from the rim and press on the second tire bead in order to fit the pliers (E/11).
- Turn clockwise and lubricate the beads and the rim with the proper grease. At the same time, advance the roller with small movements towards to the rim center until the tire is completely set on the rim as shown in the figure E/12.
- Remove the pliers out of the rim and bring the tool-holder arm out of the working position.
- Lower the chuck, and then close the chuck jaw to set the wheel on the frame plate vertically.



A mechanical lifting device must be used when handling wheels weighing more than 240 lbs.

Tire inflation must be done by placing the tire inside the safety cage.

CHAPTER 6 - ORDINARY MAINTENANCE



Each maintenance operation must be effected only after the disconnection of the plug from electric network.

Refer to the user and maintenance manuals for details on the routing maintenance of the generator and the compressor.

To ensure that this tire changer works perfectly over the years, carry out the routine maintenance schedule described below:

1) Lubricate the following parts from time to time, after a thorough cleaning with naphtha:

- the various swivels on the spindle
- the tool bracket slide runner
- the carriage guide plate.

2) Grease the chuck arm cylinder from time to time and also its swivel using ordinary lubricating grease.

3) From time to time check the oil level in the hydraulic power pack. Use the dipstick under the reservoir cap.

If necessary top up with Esso Nuto H46 or similar hydraulic oil (eg, Agip Oso 46, Shell Tellus Oil 46, Mobil DTE 25, Castrol Hyspin AWS 46, Chevron RPM EP Hydraulic Oil 46, BP Energol HLP).

4) From time to time check the oil level in the gear unit which, when the tool carrier bracket is completely lowered at end travel, should not show the sight glass on the gear casing as completely empty. If necessary top up with Esso Spartan EP 320 or similar oil (eg, Agip F1 REP 237, BP GRX P 320, Chevron Gear Compound 320, Mobil Gear 632, Shell Omala Oil 320, Castrol Alpha SP 320).



If the oil in the gear unit or the hydraulic power pack has to be changed, note that the gear unit casing and the power pack reservoir have specific drain plug.



Dispose of the used oil following the present legislation on the matter.

CHAPTER 7 - TROUBLE SHOOTING

TROUBLE:	POSSIBLE CAUSE:	SOLUTION:
After having switched on the power switch, the pilot lamp does not light on and no control can function.	The power plug is not inserted.	Insert the plug correctly in its socket.
	No power from the mains electric supply.	Reset the mains electric supply.
After having switched on the power switch, the pilot lamp light on but the motor on the hydraulic power pack does not function.	The circuit breaker is not switched on.	Switch on the circuit breaker.

	<p>If, despite of the above mentioned indications the tire changer does not work properly, do not use it and call for technical assistance.</p>
---	--

CHAPTER 8 – MOVING, STORING AND SCRAPPING

8.1 MOVING THE MACHINE

To move the machines, follow these instructions:

- 1) Completely fold down the tire changer.
- 2) Close completely the jaws of the chuck.
- 3) Unscrew the screws that secure the tire changer on the van.
- 4) Use a forklift truck of suitable loading capacity, take the tire changer off the van and put it away in a sheltered and covered place.

8.2 STORING

If the machine as to be stored for a long time (3-4 months) you have to:

- 1) Grease all the parts that could be damaged if they dry out:
 - the self-centering chuck
 - the tool holding arm
 - the slides of the carriage
 - the tool
- 2) Empty oil/hydraulic fluid reservoirs and wrap the machine in a sheet of protective plastic to prevent dust from reaching the internal working parts.

If the machine as to working again after a long storing period, it is necessary to:

- fill the oil into the reservoirs again.

8.3 SCRAPPING A MACHINE

When your machine's working life is over and it can no longer be used, it must be made inoperative by removing any connection to power sources.

These units are considered as special waste material, and should be broken down into uniform parts and disposed of in compliance with current laws and regulations. If the packing are not polluting or non-biodegradable, deliver them to appropriate handling station.



If this machine catches fire, use dust or CO2.

CHAPTER 9 – OPTIONAL ACCESSORIES

The following optional accessories are available for the tire changer:

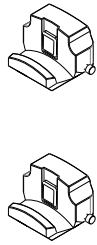
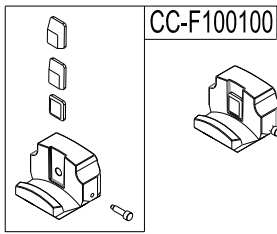

CC-F100100 Set of 4 jaws for alloy rims

Mounted on the jaws of the chuck, they are used to operate on alloy rims without damaging them.

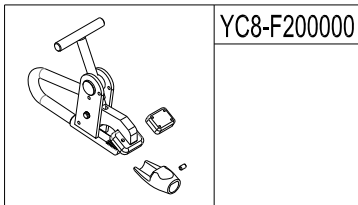

YC8-F200000 Pliers for alloy rims

It is used to work with alloy rims without damaging them.

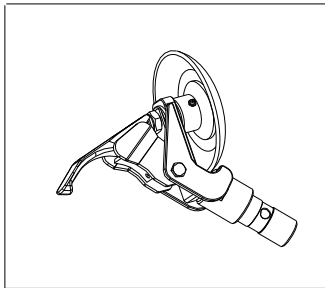

CC-620000 Double tools

CHAPTER 10 - HYDRAULIC SCHEME AND ELECTRIC DIAGRAM

HYDRAULIC SCHEME

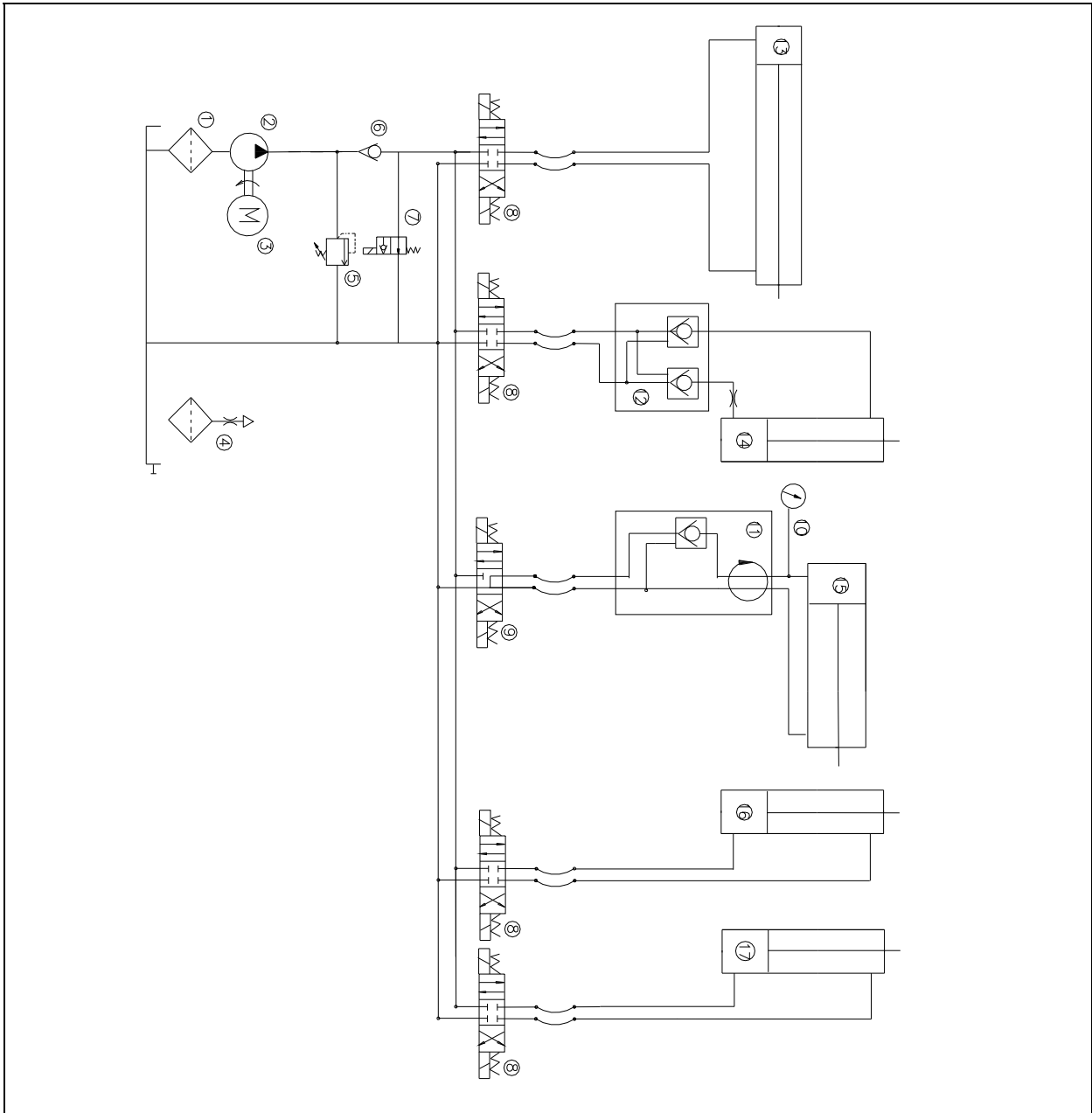

1	Oil filter	10	Pressure gauge
2	Gear pump	11	Stop valve
3	Pump motor	12	Stop valve
4	Oil level plug	13	Carriage cylinder
5	Pressure overload valve	14	Chuck arm cylinder
6	Check valve	15	Chuck opening/closing cylinder
7	2/2 solenoid valve normally open	16	Tool moving cylinder
8	Modular directional solenoid valve	17	Tool tilting cylinder
9	Modular directional solenoid valve		

ELECTRIC DIAGRAM

38V-400V/3PH

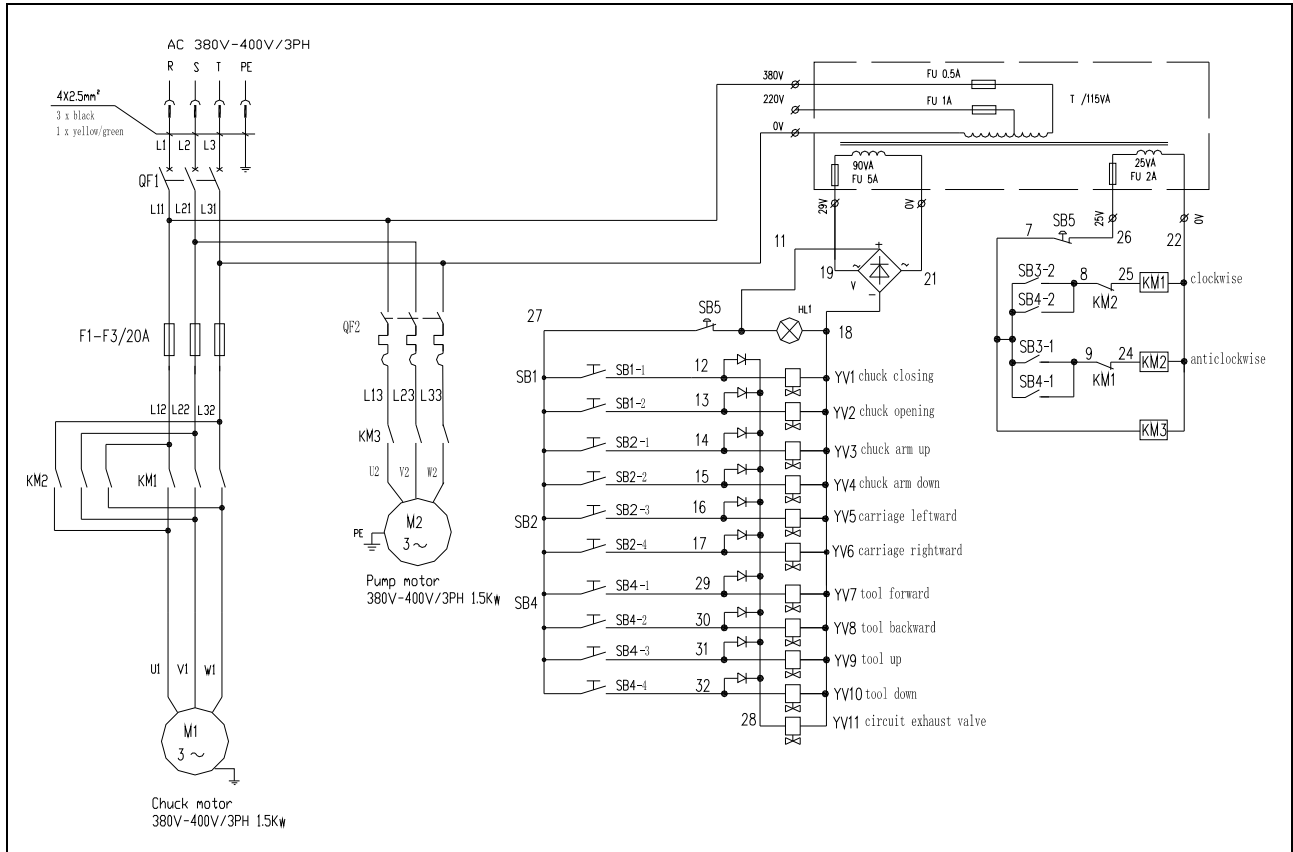

QF1	Power main switch
QF2	Circuit breaker
M1	Chuck motor
M2	Pump motor
KM1	Contactors AC – clockwise direction
KM2	Contactors AC – anticlockwise direction
KM3	Contactors AC – emergency stop
HL1	Pilot lamp
V	Rectifier bridge
T	Transformer
SB1	Chuck switch
SB2	Joystick 1
SB3	Joystick 3/foot pedal
SB4	Joystick 2
SB5	Emergency stop knob
YV1	Solenoid valve – chuck closing
YV2	Solenoid valve – chuck opening
YV3	Solenoid valve – chuck arm lifting
YV4	Solenoid valve – chuck arm lowering
YV5	Solenoid valve – carriage moving toward chuck
YV6	Solenoid valve – carriage moving away from chuck
YV7	Solenoid valve – tool forwarding
YV8	Solenoid valve – tool backwarding
YV9	Solenoid valve – tool arm lifting
YV10	Solenoid valve – tool arm lowering
YV11	Circuit exhaust solenoid valve

PARTS LIST

GENERAL BREAKDOWN

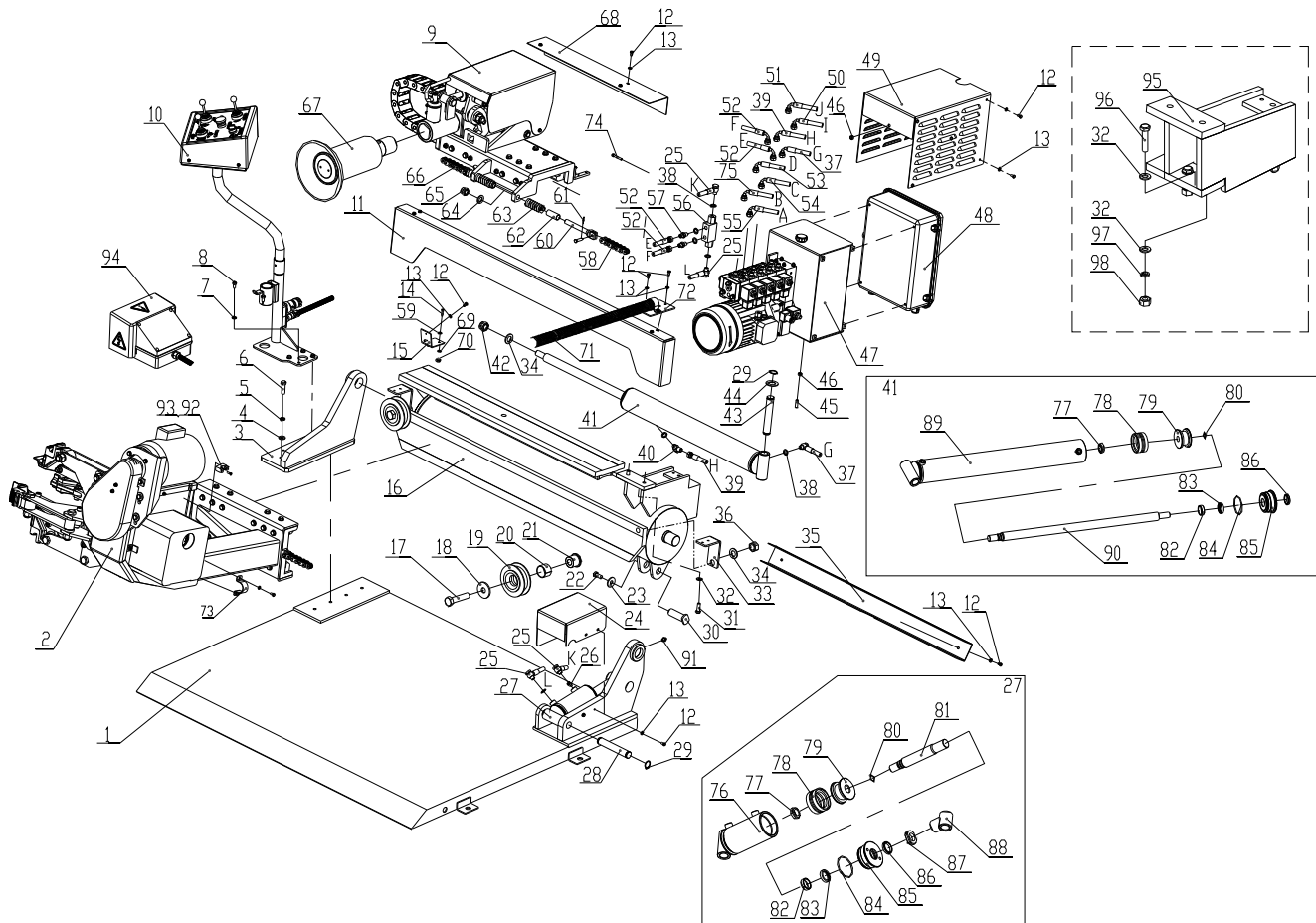

GENERAL BREAKDOWN

ITEM	PART NO.	DESCRIPTION	QTY
1	C51B110000	Frame	1
2	C51B300000B	Self-centering chuck unit	1
3	C51B010000	Guide support	1
4	0205013	Washer D.12 - GB/T97.1	4
5	0208009	Locking washer D.12 - GB/T93/	4
6	0201148	Screw M12X40 - GB/T5783	4
7	0205008	Washer D.8 - GB/T97.1	4
8	0201026	Screw M8X16 - GB/T5783	4

ITEM	PART NO.	DESCRIPTION	QTY
9	C51B400000	Carriage unit	1
10	C51BD12000	Control unit	1
11	C51B000018	Chain protection	1
12	0201011	Screw M6X12 - GB/T5783	18
13	0205006	Washer D.6 - GB/T97.1	23
14	0202021	Screw M5X20 - GB/T70.1	2
15	C51B000016	Support	1
16	C51B200000	Guide	1
17	0201185	Screw M20X90 - GB/T5783	2
18	C51B000005	Pulley spacer	2
19	C51B000003	Chain pulley	2
20	0210054	Bush SF-1/4028	2
21	C51B000004	Pulley pin	2
22	0201078	Screw M12X25 - GB/T5783	1
23	0205014	Washer D.12 - GB/T96/12	1
24	C51B000013	Chuck arm cylinder cover	1
25	304-JJ1300	Hydraulic hose L=1300	2
26	BZ-GZ-003	Flow restrictor	1
27	C51BY30000	Chuck arm cylinder	1
28	C51B000007	Cylinder lower pin	1
29	0212004	Seeger D.25 - GB/T894.1	4
30	C51B000006	Cylinder upper pin	1
31	0201049	Screw M10X30 - GB/T5783	2
32	0205011	Washer D.10 - GB/T97.1	8
33	C51B000017	Chain protection support	2
34	0205022	Washer D.20 - GB/T97.1	3
35	C51B000010	Hose cover	1
36	0203020	Nut M20 - GB/T6170	2
37	304-WJ950	Hydraulic hose L=950	1
38	0313001	Washer 1/4	8
39	304-ZW1600	Hydraulic hose L=1600	1
40	0303030	Banjo union 1/4	1
41	C51BY40000	Carriage cylinder	1
42	0204027	Self-locking nut M20 - GB/T889.1	1
43	C51B000008	Carriage cylinder pin	1
44	YC8-4399289	Washer	2
45	0209048	Screw M8X30 - GB/T77	1

ITEM	PART NO.	DESCRIPTION	QTY
46	0203008	Nut M8 - GB/T6170	2
47	C51BY10000	Hydraulic power unit	1
48	C51BD11000	Electric unit	1
49	C51B000019	Power unit cover	1
50	304-ZW3070	Hydraulic hose L=3070	1
51	304-ZW3170	Hydraulic hose L=3170	1
52	304-ZW250	Hydraulic hose L=250	2
53	304-ZW3000	Hydraulic hose L=3000	1
54	304-WJ3200	Hydraulic hose L=3200	1
55	304-WJ1800	Hydraulic hose L=1800	1
56	0307042	Stop valve BP25000000	1
57	0303065	Union 1/4	2
58	0215094	Chain BL644X58	1
59	0205005	Washer D.5 - GB/T96	2
60	C51B000001	Chain tensioner	2
61	0213038	Split pin 2.5X25 - GB/T91	4
62	C51B000002	Spring guiding pin	2
63	C51B000023	Spring	2
64	0205020	Washer D.16 - GB/T97.1	2
65	0204008	Self-locking nut M16 - GB/T889.1	2
66	0215093	Chain BL644X46	1
67	C51B500000	Press roller unit	1
68	C51B000009	Cylinder protection	1
69	0205004	Washer D.5 - GB/T97.1	2
70	0204002	Self-locking nut M5 - GB/T889.1	2
71	C51B000022	Pipe conduit	1
72	C51B000020	Support	1
73	C51B000021	Pipe U bolt	2
74	0202035	Screw M6X40 - GB/T70.1	1
75	304-WJ1850	Hydraulic hose L=1850	1
76	C51BY32000	Chuck arm cylinder liner	1
77	0204048	Nut M22X1.5 - GB/T6173	2
78	0312014	Gasket 70X50X22.4	2
79	YA-70-3	Piston	2
80	0309022	O-ring 24X2.4	2
81	C51BY38004	Cylinder shaft	1
82	0305007	Guiding ring 30X10X2.5	2

ITEM	PART NO.	DESCRIPTION	QTY
83	0310009	Seal 30X38X7	2
84	0309050	O-ring 70X3.1	2
85	C51AY38005	Cylinder guiding cover	2
86	0311005	Scraper 30X38X5/6.5	2
87	0204072	Nut M27X1.5 - GB/T812	1
88	C51B000014	Cylinder upper pin support	1
89	C51AY42000	Carriage cylinder liner	1
90	C51BY48001	Cylinder shaft	1
91	0215020	Greaser M10X1	2
92	0206041	Screw M5X12 - GB/T818	2
93	0508304	Pipe clamp M18	2
94	0505033	Pedal control unit	1
95	C51B220100	Motor support extension	1
96	0201051	Screw M10X45 - GB/T5782	3
97	0208007	Locking washer D.10 - GB/T93	3
98	0203032	Nut M10 - GB/T6170	3

SELF-CENTERING CHUCK UNIT

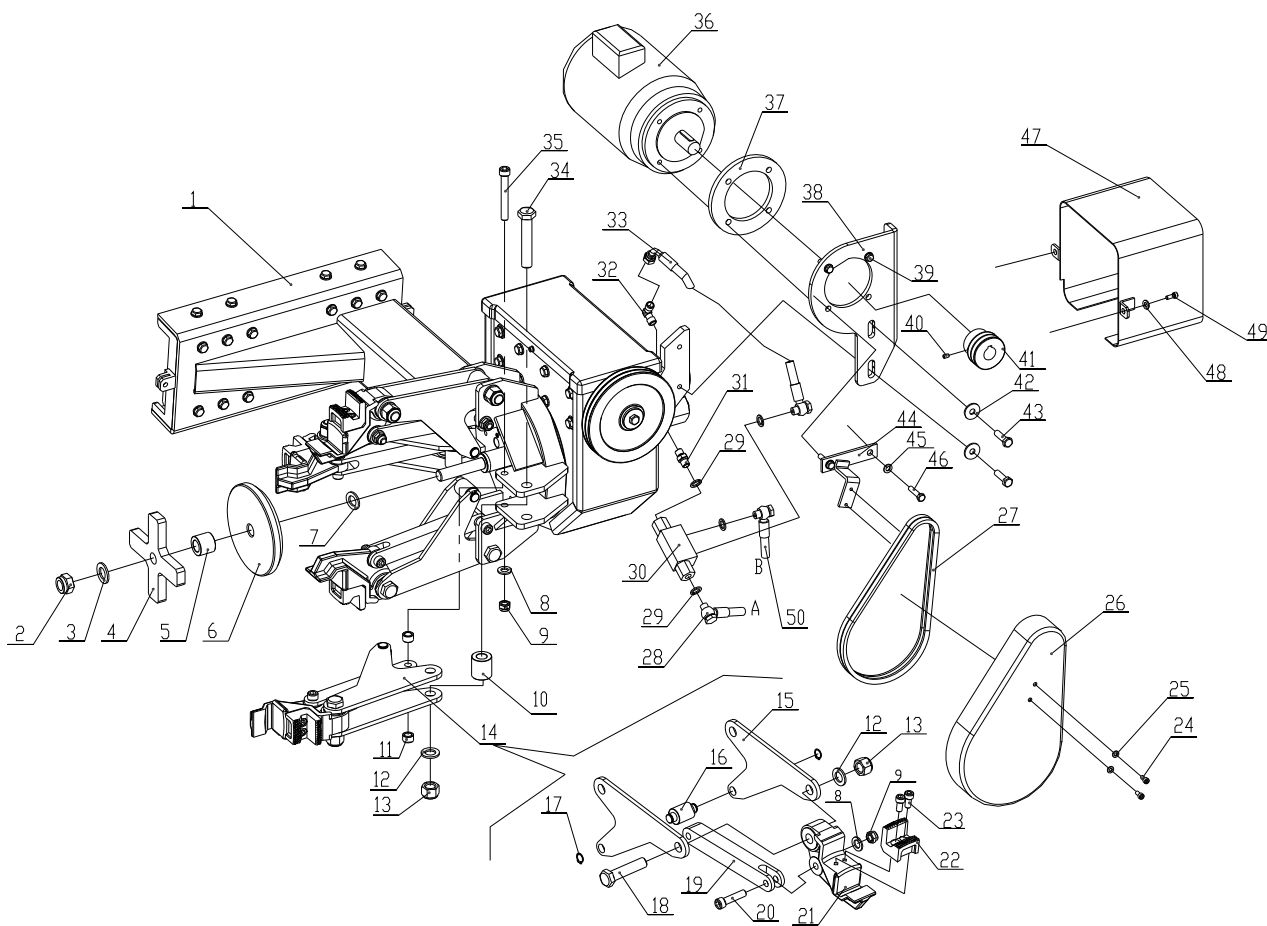

SELF-CENTERING CHUCK UNIT

ITEM	PART NO.	DESCRIPTION	QTY
1	C51B300000A	Chuck arm unit	1
2	0204029	Self-locking nut M20X1.5 - GB/T889.2	1
3	0205022	Washer D.20 - GB/T97.1	1
4	CC-580102	Cross piece	1
5	CC-580103	Spacer	1
6	CC-580101	Chuck opening control plate	1
7	CC-580104	Spacer A	1
8	0205013	Washer D.12 - GB/T97.1	8
9	0204007	Self-locking nut M12 - GB/T889.1	8
10	CC-510204	Spacer	4
11	CC-510205	Spacer	8
12	0205021	Washer D.18 - GB/T97.1	8
13	0204010	Self-locking nut M18X1.5 - GB/T889.2	8

ITEM	PART NO.	DESCRIPTION	QTY
14	C51B340000	Self-centering clamp unit	4
15	C51B340001	Clamp arm	8
16	CC-510203	Pin	4
17	0212002	Seeger D.16	8
18	0201118	Screw M18X1.5X80 - GB/T5785	4
19	C51B340002	Clamp lever	4
20	0202072	Screw M12X50 - GB/T70.1/12.9	4
21	CC-510102	Clamp support	4
22	CC-510101	Clamp	4
23	0202060	Screw M10X20 - GB/T70.1	8
24	0202024	Screw M6X12 - GB/T70.1	2
25	0205006	Washer D.6 - GB/T97.1	2
26	CC-840100A	Belt casing	1
27	0511077	Driven belt V800	2
28	304-WJ1800	Hydraulic hose L=1800	1
29	0313001	Washer 1/4	4
30	0307020	Stop valve BP17000000	1
31	0303065	Union 1/4	1
32	0303010	90° union 1/4	1
33	302-WJ310	Hydraulic hose L=310	1
34	0201105	Screw M18X1.5X100 - GB/T5785	4
35	0202095	Screw M12X90 - GB/T70.1	4
36	0509026	220/380V/50/60HZ/1.5KW 4P	1
37	CC-830102V	Spacer	1
38	C51B331000	Motor support	1
39	0201031	Screw GB/T5783/M8X30	2
40	0209046	Screw M8X10 - GB/T80	1
41	YC8-3000975	Belt pulley	1
42	0205010	Washer D.10 - GB/T96	2
43	0201117	Screw M8X35 - GB/T5783	2
44	C51B330001	Support	1
45	0205008	Washer D.8 - GB/T97.1	4
46	0201050	Screw M10X35 - GB/T5783	2
47	C51B350000	Pivot union cover	1
48	0205008	Washer D.8 - GB/T97.1	2
49	0202040	Screw M8X16 - GB/T70.1	2
50	304-WJ1850	Hydraulic hose L=1850	1

CHUCK ARM UNIT

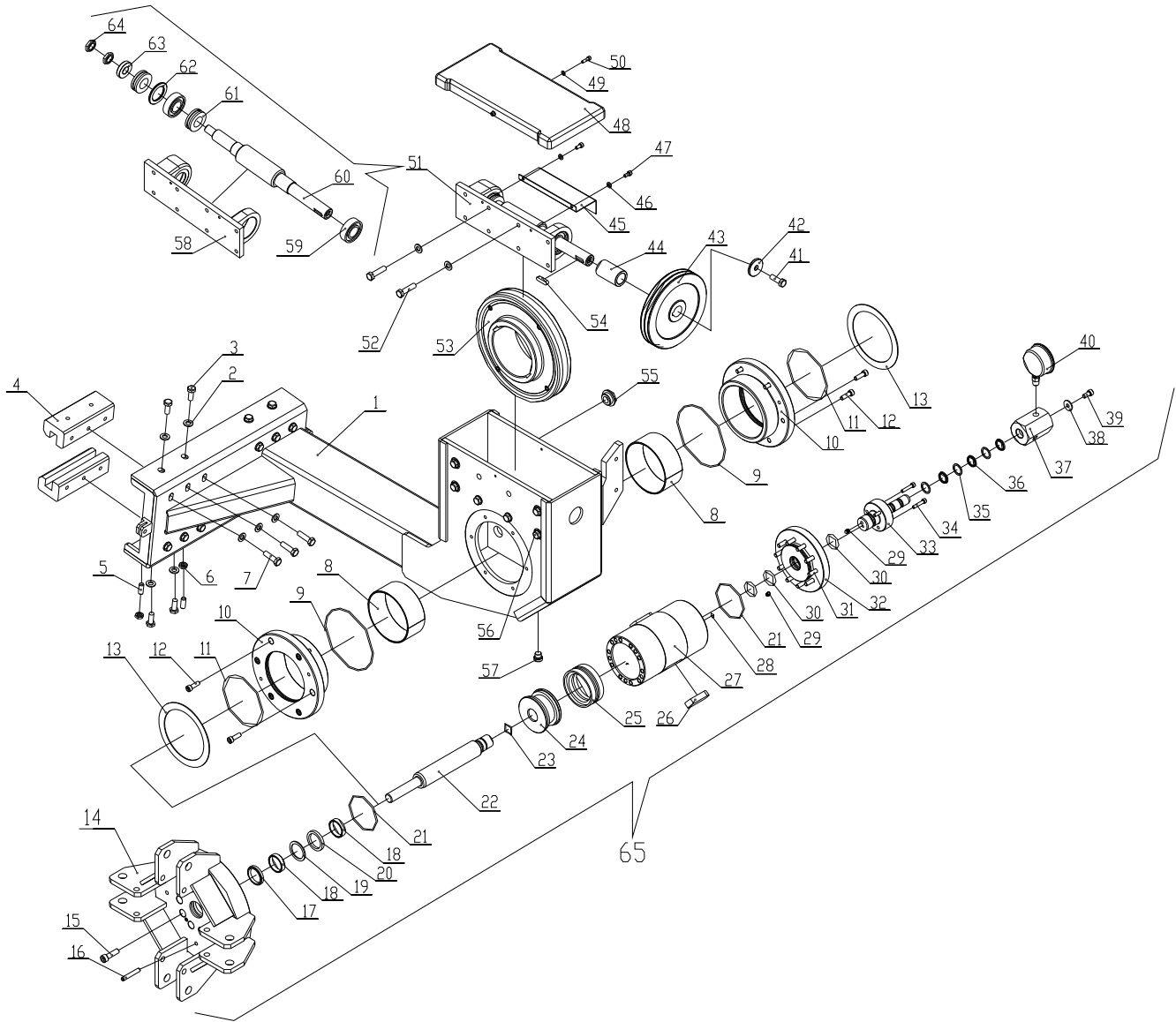

CHUCK ARM UNIT

ITEM	PART NO.	DESCRIPTION	QTY
1	C51B310000	Chuck arm	1
2	0205011	Washer D.10 - GB/T97.1	28
3	0201064	Screw M10X25 - GB/T5783	8
4	CC-201010	Carriage slider	4
5	0209024	Screw M10X25 - GB/T77	4
6	0204012	Nut M10 - GB/T6172.1	4
7	0201050	Screw M10X35 - GB/T5781	12

ITEM	PART NO.	DESCRIPTION	QTY
8	0210037	Bush SF-1/11550	2
9	0309047	O-ring 145X3.1	2
10	CC-810101	Flange	2
11	0309012	O-ring 120X3.1	2
12	0202047	Screw M8X25 - GB/T70.1	12
13	CC-810104	End bearing	2
14	CC-520100	Chuck turntable	1
15	0202079	Screw M10X35 - GB/T70.1	10
16	0213067	Pin 8X50 - GB/T120.2/	5
17	0311006	Scraper 35X43	1
18	0305007	Guiding ring 35X10X2.5	2
19	C-2C120-85-9	Seal ring 35X45X2	1
20	0310010	Seal 35X45X6	1
21	0309076	O-ring 85X3.1	2
22	C-2C120-85-2	Chuck cylinder shaft	1
23	0309023	O-ring 28X3.1	1
24	C-2C120-85-3	Piston	1
25	0312017	Gasket 85X65	1
26	0213029	Tab 20X60 - GB/T1096	2
27	C-2C120-85-1	Chuck cylinder liner	1
28	0309007	O-ring 11X1.9	1
29	0305001	Plug QD07	2
30	0309026	O-ring 36X3.5	3
31	0202042	Screw M8X40 - GB/T70.1	10
32	C-2C120-85-4	Cylinder back cover	1
33	C-2C120-85-5	Pivot union pin	1
34	0202026	Screw M6X30 - GB/T70.1	3
35	C-2C120-85-7	Seal ring 20X26X1.5	3
36	0313014	Seal 20X3.55	3
37	C-2C120-85-6	Pivot union body	1
38	0205009	Washer D.8 - GB/T96	1
39	0202040	Screw M8X16 - GB/T70.1	1
40	0305056	Pressure gauge 60X250	1
41	0201062	Screw M10X20 - GB/T5783	1
42	YC8-3001068	Washer	1
43	YC8-3001052b	Driven pulley	1
44	CC-410103	Bush	1

ITEM	PART NO.	DESCRIPTION	QTY
45	YC8-3001010	Oil screen	1
46	0205006	Washer D.6 - GB/T97.1	2
47	0202024	Screw M6X12 - GB/T70.1	2
48	C51B300001	Cover	1
49	0205004	Washer D.5 - GB/T97.1	2
50	0202021	Screw M5X20 - GB/T70.1	2
51	C51B320000	Worm unit	1
52	0201068	Screw M10X40 - GB/T5781	2
53	CC-410101A	Helical gear	1
54	0213025	Tab 8X30 - GB/T1096	1
55	0215024	Oil indictor M27X1.5	1
56	0201051	Screw M10X45 - GB/T5781	6
57	0305016	Oil plug 1/4	1
58	C51B320001	Worm support	1
59	0214019	Bearing 6205	2
60	CC-410102	Worm	1
61	0214009	Thrust bearing 51205	2
62	CC-410104	Washer	1
63	YC8-3001114	Spacer	1
64	0204014	Nut M16X1.5	2
65	C-2C120-85-0	Chuck cylinder unit	1

CARRIAGE UNIT

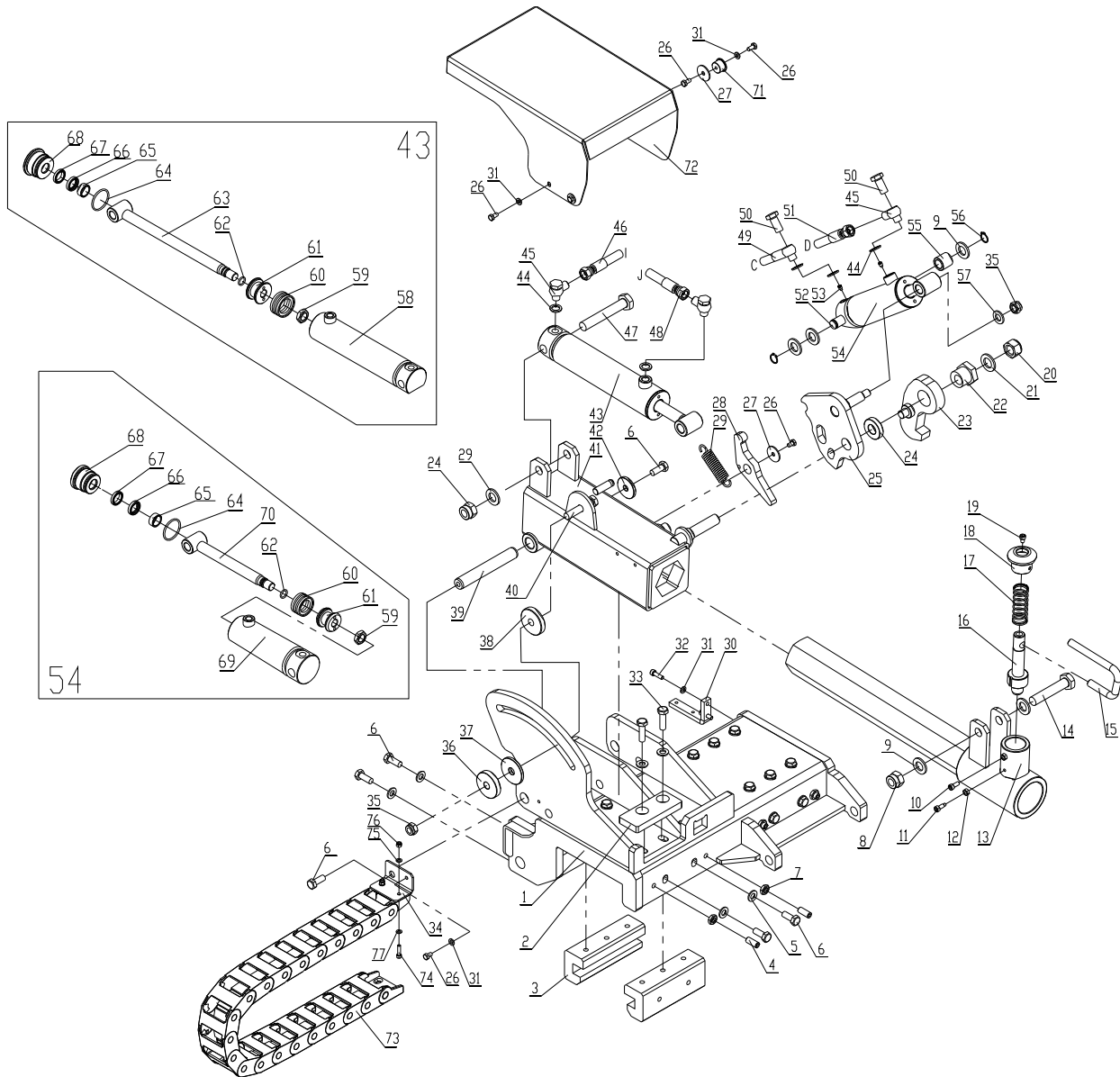

CARRIAGE UNIT

ITEM	PART NO.	DESCRIPTION	QTY
1	C51B410000	Carriage	1
2	C51B400010	Rubber pad	1
3	CC-201010	Slider	4
4	0209024	Screw M10X25 - GB/T77	4
5	0205011	Washer D.10 - GB/T97.1	20
6	0201064	Screw GB/T5783/M10X25	10
7	0204012	Nut M10 - GB/T6172.1	4

ITEM	PART NO.	DESCRIPTION	QTY
8	0204008	Self-locking nut M16 - GB/T889.1	2
9	0205020	Washer D.16 - GB/T97.1	6
10	0202025	Screw M6X14 - GB/T70.1	1
11	C56B410005	Guide screw	1
12	0203004	Nut M6 - GB52	2
13	C51B430000	Hexagonal arm	1
14	0201200	Screw M16X80 - GB/T5782	1
15	C51B400008	Handle	1
16	C51B400007	Positioning pin	1
17	C56B412003	Spring	1
18	C56B412002	Spring cap	1
19	0202037	Screw M6X8 - GB/T70.1	1
20	0204009	Self-locking nut M18 - GB/T889.1	1
21	0205021	Washer D.18 - GB/T97.1	1
22	CC-610001	Off-center bush	1
23	C51B450000	Hook	1
24	C51B400003	Spacer	1
25	C51B440000	Cam	1
26	0201011	Screw M6X12 - GB/T5781	6
27	C51B400004	Washer	2
28	C51B400002	Cam limiter	1
29	C51B400011	Spring	1
30	C51B400009	Cylinder protection support	1
31	0205006	Washer D.6 - GB/T97.1	6
32	0202033	Screw M6X20 - GB/T70.1	2
33	0201050	Screw M10X35 - GB/T5783	12
34	C51B000015	Chain holding plate	1
35	0204007	Self-locking nut M12 - GB/T889.1	2
36	C56B320005	Spacer	1
37	C56B320006	Nylon washer	1
38	C56B320007	Nylon washer	1
39	C51B400001	Pin	1
40	0201081	Screw M12X60 - GB/T5782	1
41	C51B420000	Post	1
42	YC8-3001068	Washer	1
43	C51BY20000	Tool moving cylinder unit	1
44	0313001	Washer 1/4	5

ITEM	PART NO.	DESCRIPTION	QTY
45	0303030	Banjo union 1/4	3
46	304-ZW3070	Hydraulic hose L=3070	1
47	0201101	Screw M16X100 - GB/T5782	1
48	304-ZW3170	Hydraulic hose L=3170	1
49	304-WJ3200	Hydraulic hose L=3200	1
50	BZ-720B-0401	Banjo bolt	2
51	304-ZW3000	Hydraulic hose L=3000	1
52	C51B400005	Cylinder lower pin	1
53	BZ-GZ-003	Flow restrictor	2
54	C51BY60000	Tool tilting cylinder unit	1
55	C51B400006	Spacer B	1
56	0212002	Seeger D.16 - GB/T894.1	2
57	0205013	Washer D.12 - GB/T97.1	2
58	C51BY21000	Moving cylinder liner	1
59	0204014	Nut M16X1.5 - GB/T6173	2
60	0312004	Gasket 45X31X15.5	2
61	C51BY28002	Piston	2
62	0309019	O-ring 18X2.4	2
63	C51AY22000	Cylinder shaft	1
64	0309060	O-ring 45X3.1	2
65	0305007	Guiding ring 20X10X2.5	2
66	0310006	Seal 20X28X5.7	2
67	0311022	Scraper 20X28X4.5/6	2
68	C51BY28001	Cylinder guiding cover	2
69	C51BY61000	Tilting cylinder liner	1
70	C51BY62000	Cylinder shaft	1
71	C51B000012	Cover pin	1
72	C51B000011	Top cover	1
73	0511187	Plastic chain	1
74	0202021	Screw M5X20 - GB/T70.1	2
75	0205004	Washer D.5 - GB/T97.1	2
76	0204002	Self-locking nut M5 - GB/T889.1	2
77	0205005	Washer D.5 - GB/T96	2

CONTROL UNIT

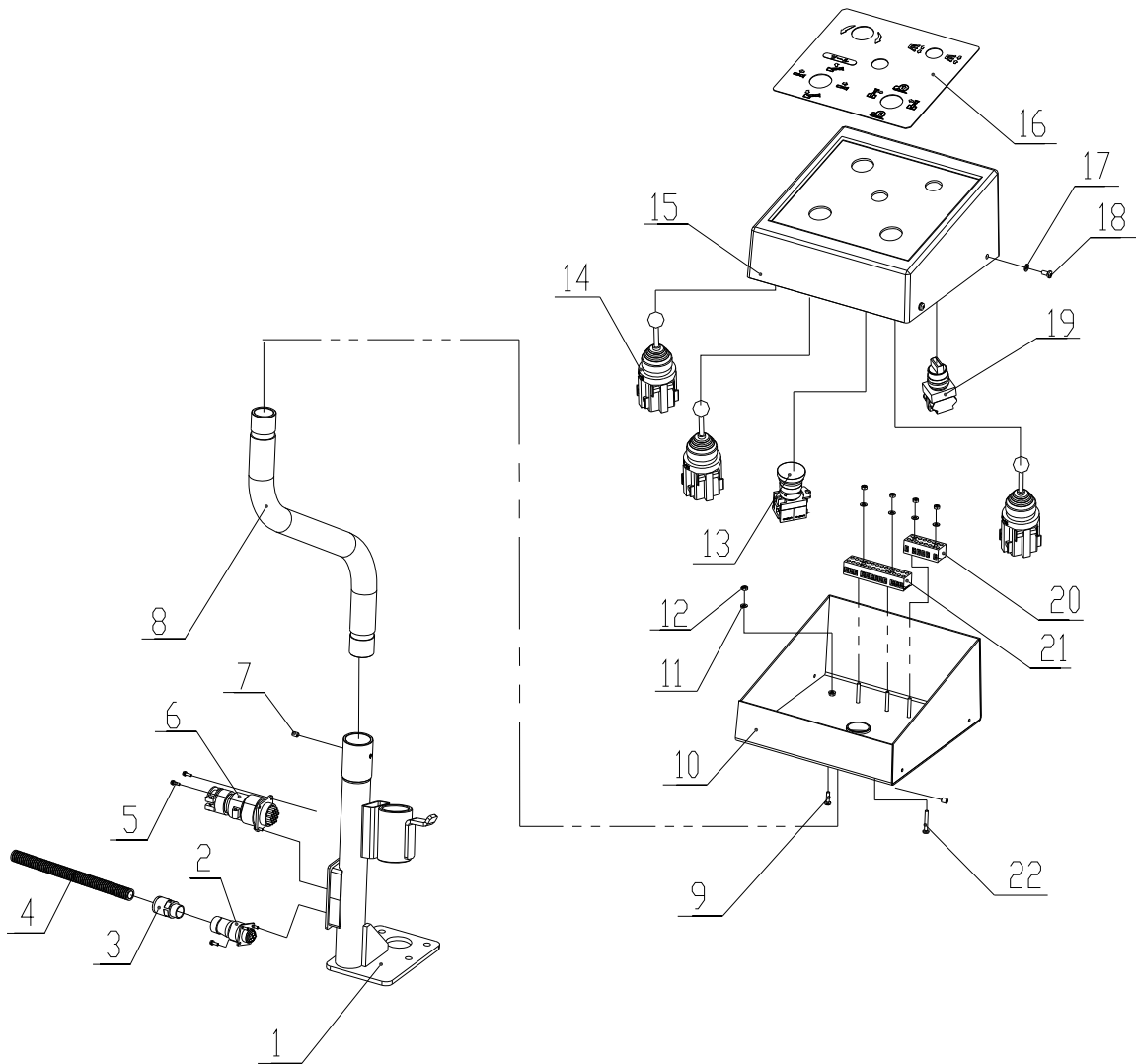

CONTROL UNIT

ITEM	PART NO.	DESCRIPTION	QTY
1	C51BD12100	Support	1
2	0508277	Cable connector with 4 pins	1
3	0508350	Conduit connector M18	1
4	0511192	Cable conduit 15.8	1
5	0508282	Cable connector with 19 pins	1
6	0201136	Screw M3X10 - GB/T9074.4	8
7	0209042	Screw M6X8 - GB/T80	4
8	C51BD12001	Pivot pipe	1

ITEM	PART NO.	DESCRIPTION	QTY
9	0206015	Screw M4X16 - GB/T818	1
10	C51BD12200	Casing	1
11	0205002	Washer D.4 - GB/T97.1	6
12	0203002	Nut M4 - GB52	6
13	0502044	Emergency stop knob	1
14	0505045	Manipulator	3
15	C51BD12002	Casing cover	1
16	C51BD12003	Control decal	1
17	0205004	Washer D.5 - GB/T97.1	4
18	0206024	Screw M5X10 - GB/T818	4
19	0502068	Chuck opening/closing switch	1
20	0507013	Terminal board H3081-6	1
21	0507009	Terminal board H3801-12	1
22	0206018	Screw M4X30 - GB/T818	4

HYDRAULIC POWER UNIT

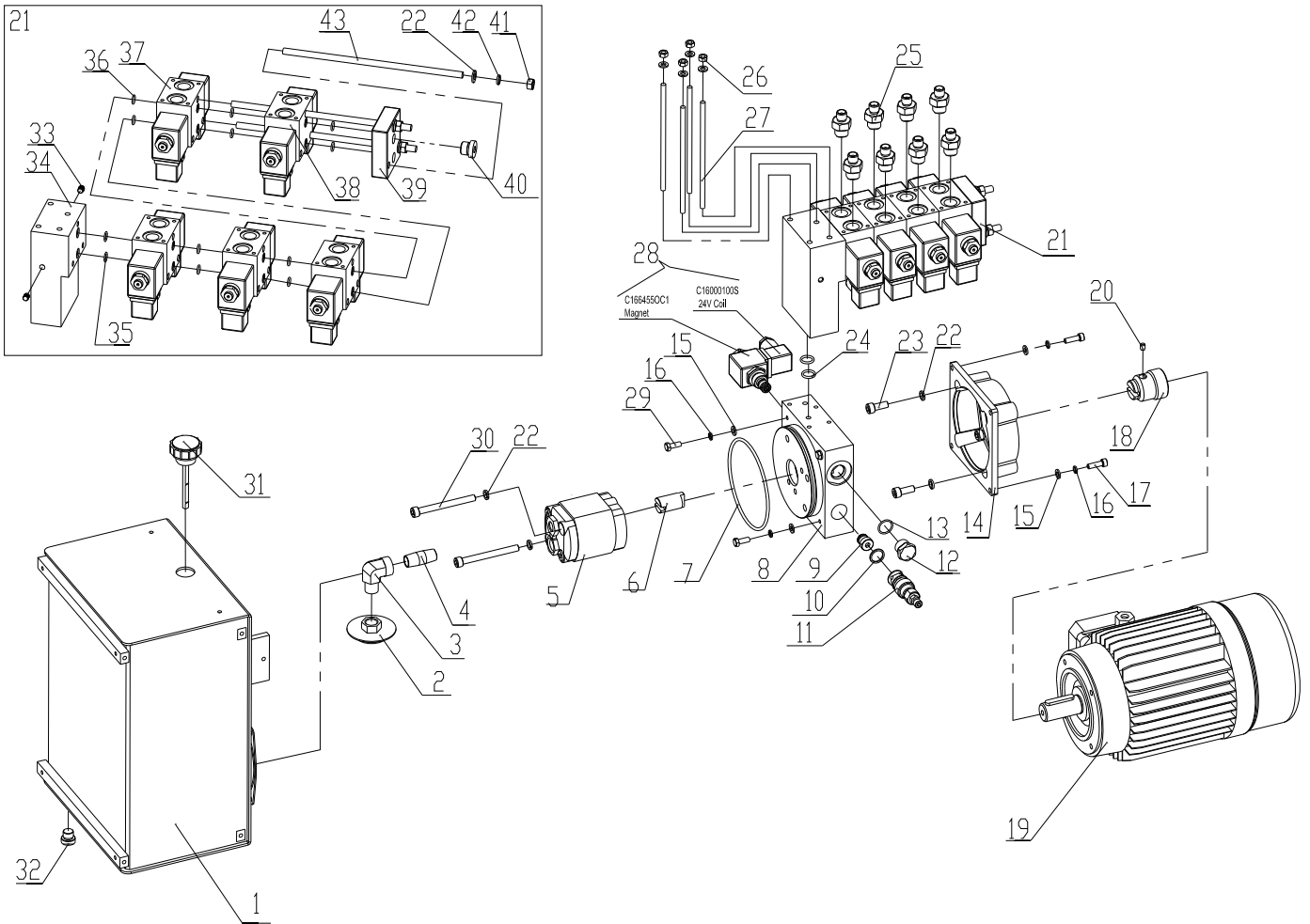

HYDRAULIC POWER UNIT

ITEM	PART NO.	DESCRIPTION	QTY
1	C51AY11000	Oil tank	1
2	0305010	Oil filter 3/8	1
3	0303007	Union 3/8	1
4	BZ-G18X40	Oil draining pipe	1
5	0301009	Gear pump 3.7cc	1
6	BZ-BJ36	Pump joint	1
7	0309013	O-ring 115X3.55	1
8	BZ-ZB-V6	Manifold	1
9	0307067	Non return valve	1
10	0313057	Copper washer 16X20	1

ITEM	PART NO.	DESCRIPTION	QTY
11	0307010	Pressure overload valve	1
12	BZ-SD-01	Manifold plug	1
13	0309054	O-ring 17X2	1
14	BZ-DJ-1B	Motor flange	1
15	0205006	Washer D.6 - GB/T97.1	12
16	0208005	Locking washer D.6 - GB/T93	8
17	0202033	Screw M6X20 - GB/T70.1	4
18	BZ-ZT24	Motor joint	1
19	0509026	220/380V/50/60HZ/1.5KW 4P	1
20	0209042	Screw M6X8 - GB/T80	1
21	W5-4+1	Multiple base with solenoid valves	1
22	0208006	Locking washer D.8 - GB/T93	9
23	0202045	Screw M8X20 - GB/T70.1	4
24	0309019	O-ring 18X2.4	2
25	0303048	Hose union 1/4	8
26	0203004	Nut M6 - GB/T6170	4
27	0213032	Stud M6x160 - GB/T901	4
28	0307098	2/2 solenoid valve normally open V389674A20	1
29	0201013	Screw M6X16 - GB/T5783	4
30	0202051	Screw M8X80 - GB/T70.1	2
31	0305025	Oil level plug 3/4	1
32	0305016	Tank plug 1/4	1
33	0305001	Sealing plug QD07	2
34	BZ-W-YC1	Interface block	1
35	0309014	O-ring 13X1.9	2
36		O-ring 8.5X1.80	10
37	0307096	ED06Z modular directional valve DC24V	4
38	0307097	ED08Z modular directional valve DC24V	1
39	0307108	Closing plate R933003329	1
40	0305018	Oil plug 3/8	1
41	0203029	Nut M8 - GB/T6170	3
42	0208006	Locking washer D.8 - GB/T93	3
43	0213078	Stud M8X280 - GB/T901	3

ELECTRIC UNIT

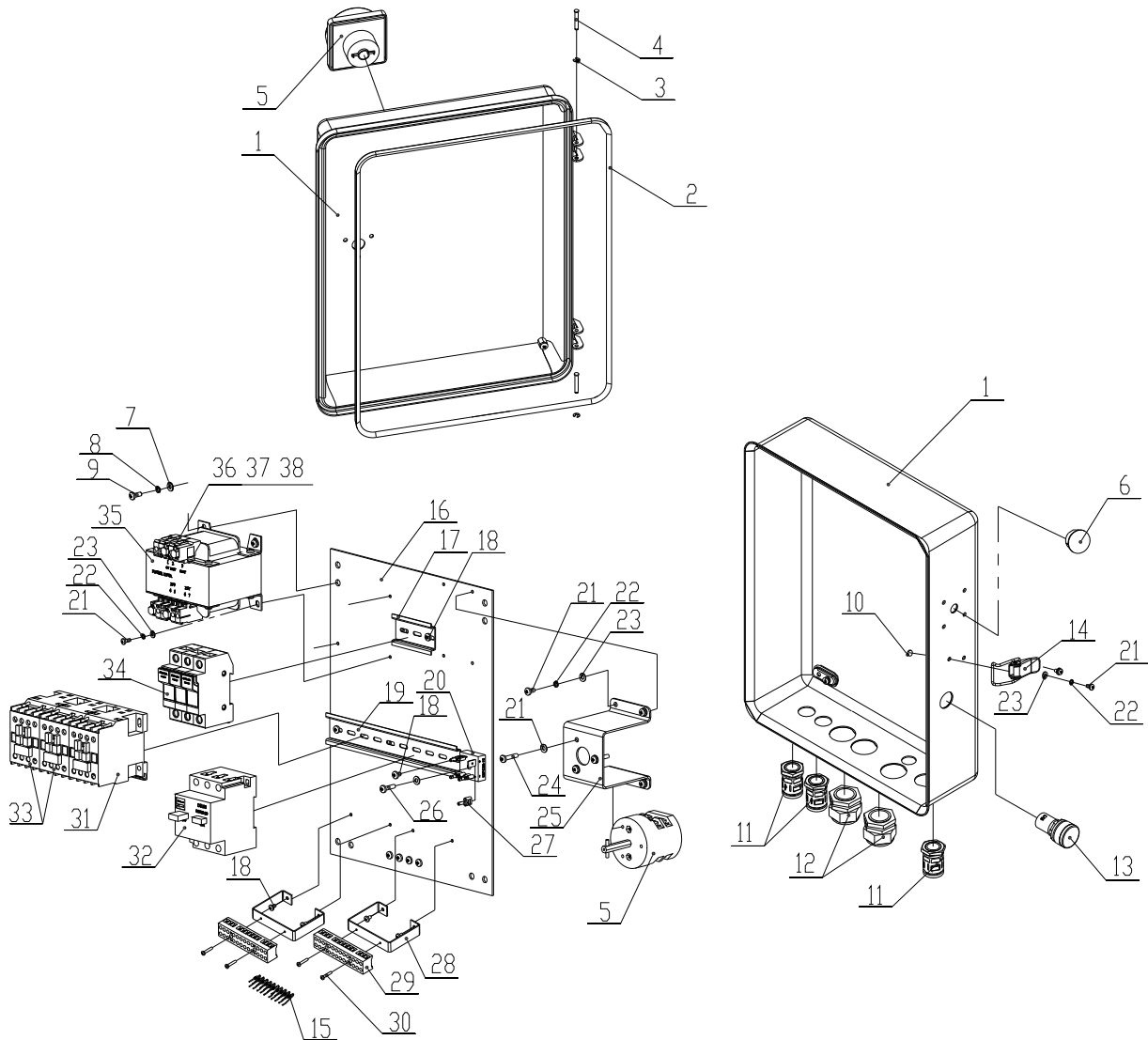

ELECTRIC UNIT

ITEM	PART NO.	DESCRIPTION	QTY
1	C51BD11100	Complete casing	1
2	0511026	Gasket	1
3	0211001	Seeger D.3.5 – GB/T896	2
4	S551-6	Pin	2
5	0505025	Power switch 20A	1
6	0508019	Plug HP-22	1
7	0205006	Washer D.6 – GB/T97.1	4
8	0208005	Locking washer D.6 – GB/T93	4

ITEM	PART NO.	DESCRIPTION	QTY
9	0206031	Screw M6X10 – GB/T818	4
10	0203002	Nut M4 - GB52	2
11	0507118	Ferrule M20	3
12	0508012	Cable holder M27	2
13	0502023	Pilot lamp AC24V	1
14	0511169	Clamp	1
15	0507027	LED IN5408	10
16	C61AD11301	Component base plate	1
17	0508330	Guide 35X60	1
18	0206019	Screw M4X6 - GB/T818	12
19	0508330	Guide 35X200	1
20	0508006	Rectifier 3510	1
21	0206023	Screw M4X8 - GB/T818	10
22	0208002	Locking washer D.4 - GB/T93	9
23	0205002	Washer D.4 - GB/T97.1	10
24	0206016	Screw M4X20 - GB/T818	4
25	C61AD11302	Switch support	1
26	0206015	Screw M4X16 - GB/T818	1
27	0507020	Reed 6.3	4
28	CC-850223	Terminal support	2
29	0507009	Terminal board H3081-12	2
30	0206002	Screw M3X16 - GB/T818	4
31	0501002	Contactactor 1210/AC24V	1
32	0501020	Breaker 6.3-10A	1
33	0501004	Contactactor 1801/AC24V	2
34	0504001	Overload cutoff 16A	3
35	0503010	Transformer 115VA 220V/380V 25V-29V	1
36	0504005	Fuse 5A/5X20	1
37	0504003	Fuse 2A/5X20	1
38	0504016	Fuse 1A/5X20	1

TOOLS AND ACCESSORIES

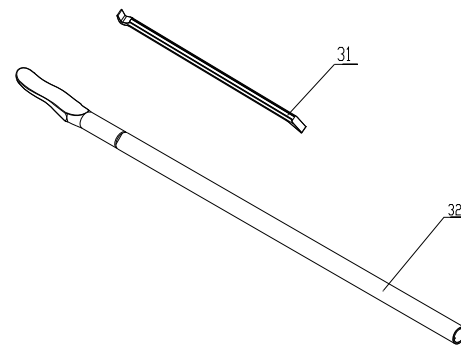
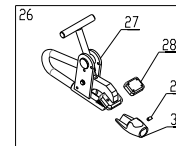
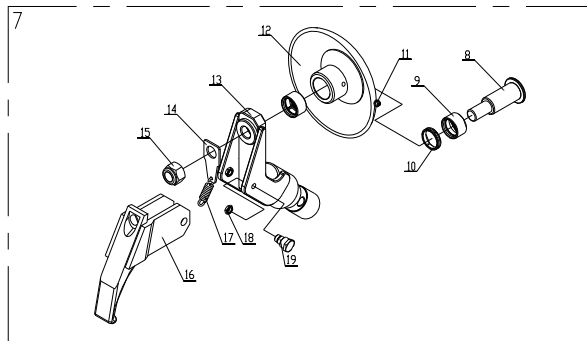
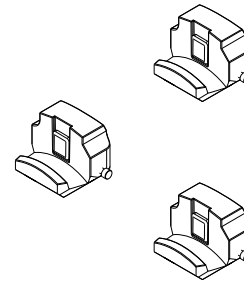
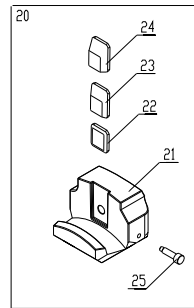
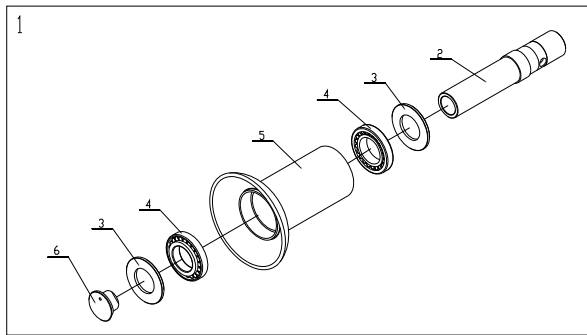

TOOLS AND ACCESSORIES

ITEM	PART NO.	DESCRIPTION	QTY
1	C51B500000	Press roller unit	1
2	C51B500001	Roller shaft	1
3	C91A000002	Washer	2
4	0214038	Bearing 30212	2
5	C51B510000	Press roller	1
6	C91A000003	Thread piece M45X1.5	1
7	CC-620000	Double tool unit	1 (Optional)
8	CC-620001	Bead breaking disc pin	1
9	CC-620002	Bead breaking disc bush	2
10	CC-620003	Spacer	1
11	0215020	Greaser 10X1	1
12	CC-620100	Bead breaking disk	1

ITEM	PART NO.	DESCRIPTION	QTY
13	CC-620200	Tool support	1
14	CC-620004	Spring connection plate	1
15	0204011	Self-locking nut M27 - GB/T889.1	1
16	CC-620300A	Short tool	1
17	CC-620005	Spring	1
18	0204014	Nut M16X1.5 - GB/T6173	2
19	CC-620007	Pin	2
20	CC-F100100	Clamp protection kit	4 (Optional)
21	CC-F100101	Clamp protection	4
22	YC8-F100102	Plastic insert 1	4
23	YC8-F100103	Plastic insert 2	4
24	YC8-F100104	Plastic insert 3	4
25	YC8-F100105	Bolt	4
26	YC8-F200000	Pliers for alloy rim	1 (Optional)
27	DB-11-00	Pliers	1
28	YC8-F201001	Plastic block	1
29	0209037	Screw M6X10 - GB/T80	1
30	YC8-F202001	Alloy protection	1
31	0511040	Short tire lever 24"	1
32	DB-12T	Long bead lifting lever	1