

# Atlas PV-9WP Addendum

## 9,000 lb. Capacity

## Two-Post Overhead Lift

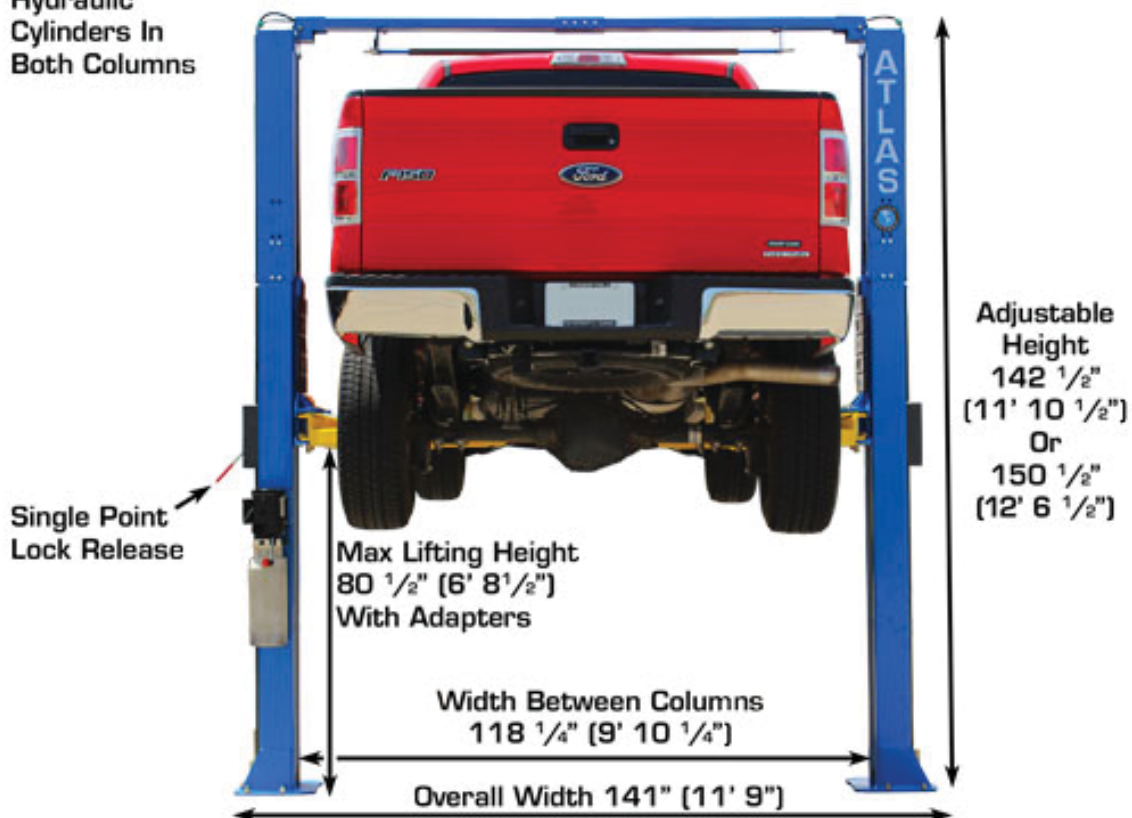


The Atlas® PV-9WP above ground hoist is 6 inches wider than the Atlas® PV-9P, giving it an overall width of 141" (11' 9") and a drive thru width of 105 1/2" (8' 9 1/2").

The extra width of the Atlas® PV-9WP two post above ground hoist allows extra wide vehicles and extra wide trailers to be pulled through.

**When establishing the installation layout, please add 6 inches between the columns to allow for the extra width of the overhead bar. (See Fig. 5 on page 10)**

Hydraulic  
Cylinders In  
Both Columns



*PV-9WP Measurements*

# Atlas PV-9WP Addendum

**9,000 lb. Capacity**

**Two-Post Overhead Lift**



(Continued)

The overhead bar width extensions pieces will come in a separate box. The contents are as follows:



**When establishing the installation layout, please add 6 inches between the columns to allow for the extra width of the overhead bar. (See Fig. 5 on page 10)**

# INSTALLATION & OPERATION MANUAL

# Atlas PV-9P & PV-9HP

9,000 lb. Capacity  
Two-Post Overhead Lift



**Atlas Automotive Equipment**  
[www.atlasautoequipment.com](http://www.atlasautoequipment.com)  
(866) 898-2604

**Read this entire manual before operation begins.**

Record below the following information which is located on the serial number data plate.

Serial No. \_\_\_\_\_

Model No. \_\_\_\_\_

Date of Installation \_\_\_\_\_

# ———— Contents ————

Specifications . . . . .	4
Installation Requirement . . . . .	6
Installation Steps . . . . .	8
Exploded View . . . . .	30
Test Run . . . . .	34
Operation Instructions. . . . .	36
Maintenance Schedule. . . . .	37
Trouble Shooting . . . . .	38
PV-9P and PV-9HP Parts List . . . . .	39
Warranty . . . . .	44

---

# Specifications

---

## Clear-Floor Direct-Driven Model Features

### Model PV-9P, PV-9HP (See Fig. 1)

- Direct drive hydraulic cylinder design, minimizes the lift wear parts and breakdown ratio
- Dual hydraulic cylinders, designed and made on ANSI standards, utilizing NOK oil seal in cylinder
- Self- lubricating UHMW Polyethylene sliders and bronze bush
- Single-point safety release with dual safety design
- Clear-floor design, provides non-obstructed floor use
- Overhead safety shut-off device prevents vehicle damage
- Standard adjustable heights accommodates variety of ceiling heights

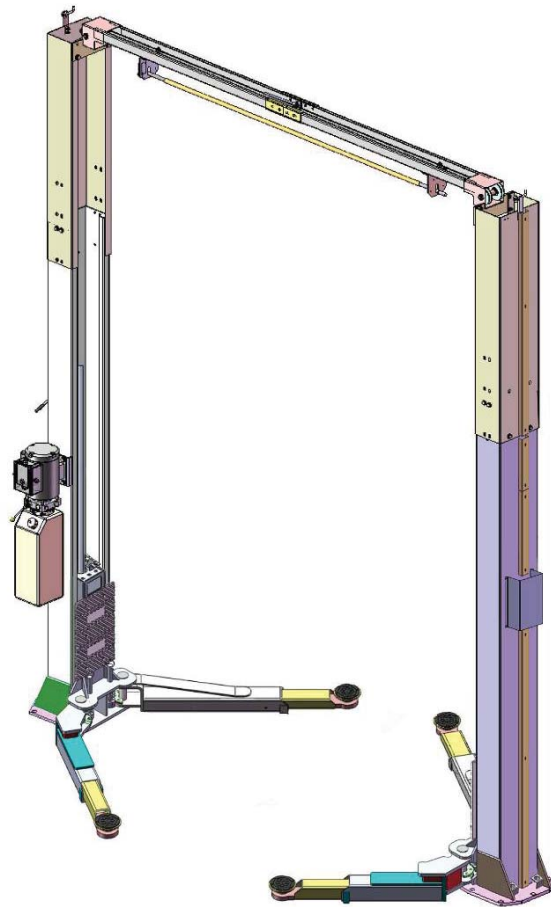


Fig. 1

# Model PV-9P PV-9HP Specifications

Model	Style	Lifting Capacity	Lifting Time	Lifting Height	Overall Height	Overall Width	Width Between Columns	Minimum Pad Height	Motor
PV-9P	Clear-floor Direct-drive	4 T 9,000 lbs	52S	1815-2044mm 71 1/2"–80 1/2"	3621/3821mm 142 1/2"/ 150 1/2"	3428mm 135"	2850mm 112 1/4"	90mm 3 1/2"	3.0 HP
PV-9HP	Clear-floor Direct-drive	4 T 9,000 lbs	52S	1815-2044mm 71 1/2"–80 1/2"	4231/4431mm 166 1/2" /174 1/2"	3428mm 135"	2850mm 112 1/4"	90mm 3 1/2"	3.0 HP

## Arm Swings View For Model PV-9P, PV-9HP

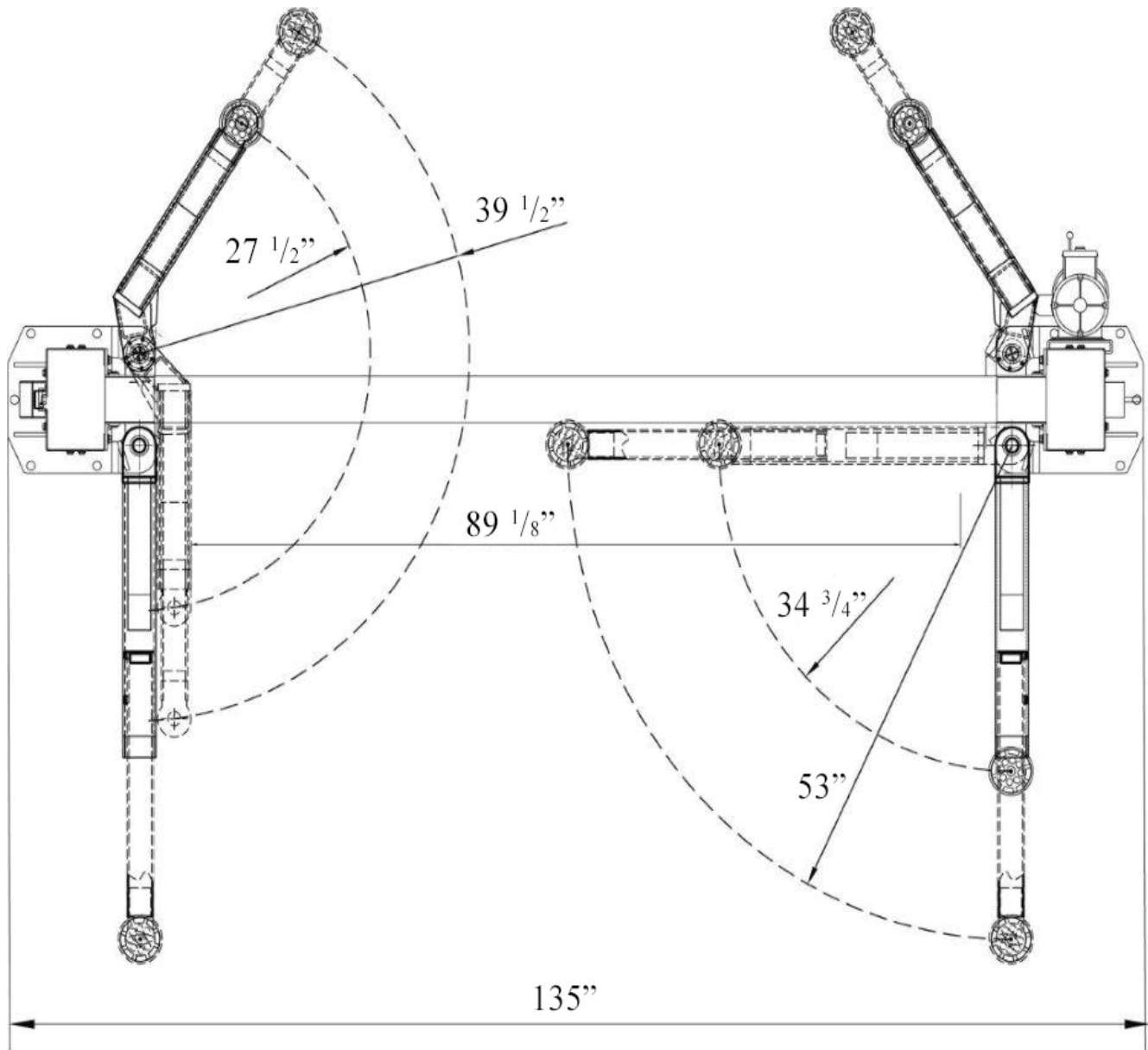


Fig. 2



# Installation Requirement

---

## Tools Required

Rotary Hammer Drill (3/4in bit)



Carpenter's Chalk



Hammer



Screw Drivers



4 Foot Level



Tape Measure (25ft)



Crescent Wrench (12")



Pliers



Ratchet & Socket (28mm)



Allen Head Wrench (3mm, 5mm, 8mm)



Wrench set (mm)  
(8#, 10#, 13#, 14#, 17#, 19#, 24#)



Vise Grips



Fig. 3



## Concrete Specifications (See Fig. 4)

Concrete specifications must be followed accordingly.

**Failure to do so may result in lift and/or vehicle falling.**

1. Concrete must have 4 inches minimum and must be totally cured before lift installation.
2. Concrete must be in good condition and must have a test strength 3,000psi minimum.
3. Floors must be level with no cracks or holes.

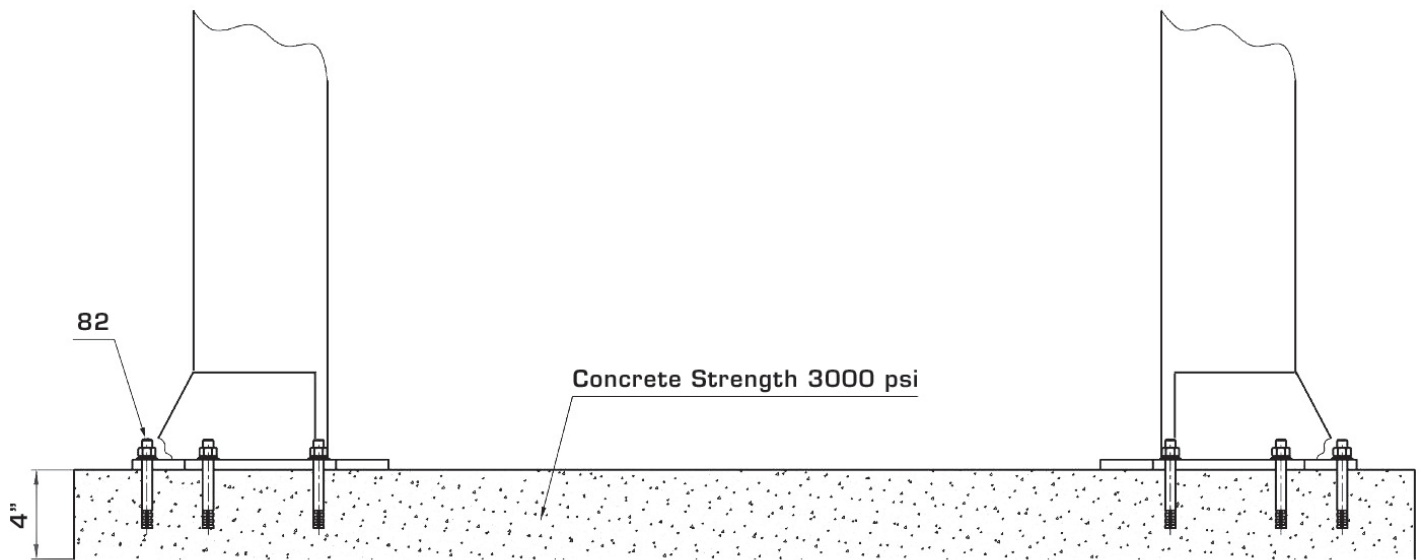


Fig. 4

## Power Supply

220 volt single phase motor on a 30 amp breaker with minimum of 10 gauge wire. Operating voltage range is 208v-230v.

# Installation Steps

## A. Location of Installation

Check and insure the installation location (concrete, layout, space size, etc.) is suitable for lift installation.

## B. Use a carpenter's chalk line to establish installation layout of base plate (See Fig.5).

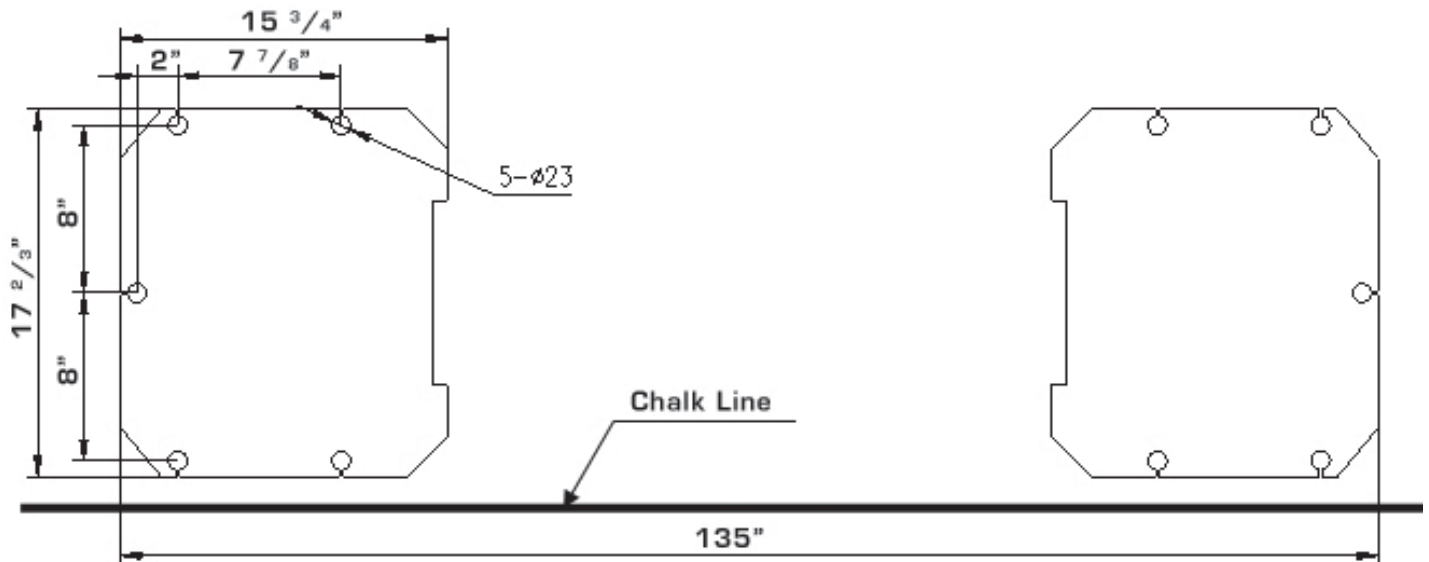


Fig. 5

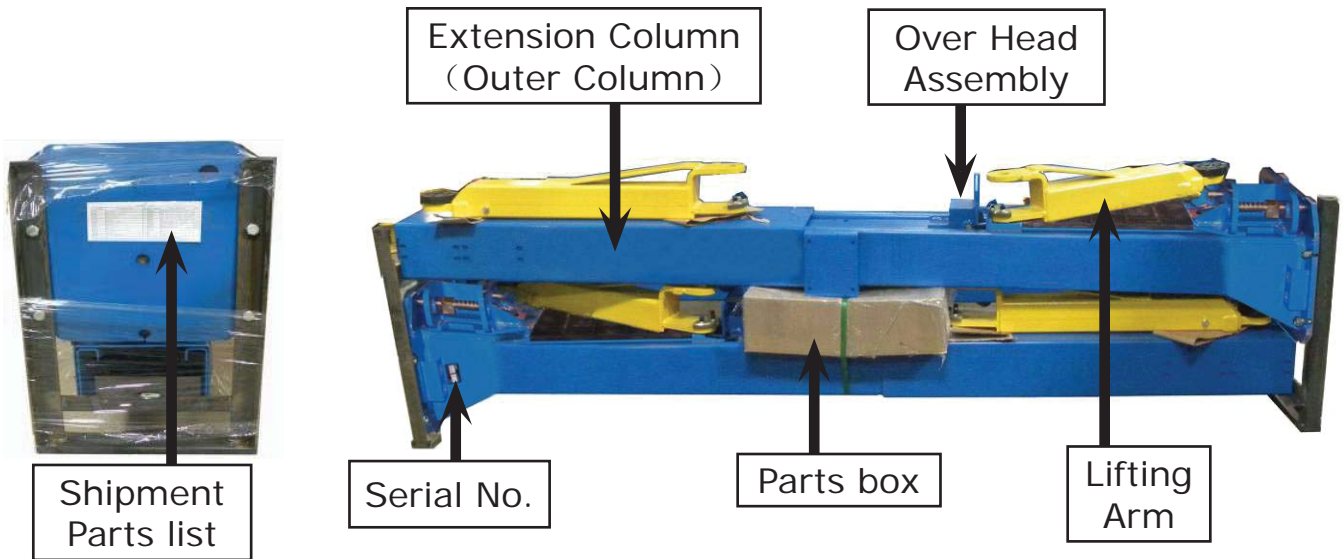
## C. Check the parts before assembly.

1. Packaged lift and hydraulic power unit (See Fig. 6).



Fig. 6

2. Move aside the lift with fork lift or hoist, and open the outer packing carefully (See Fig. 7).



**Fig. 7**

3. Loosen the screws on the upper package stand, take off the upper outer column, take out the parts in the inner column and remove the package stand
4. Move aside the parts and check the parts according to the shipment parts list (See Fig. 8, 9).



**Fig. 8 - Shipment list**



**Fig. 9 - Parts box list (93)**



## D. Install the hydraulic hose and lock release cable brackets on the extension columns (See Fig. 12).

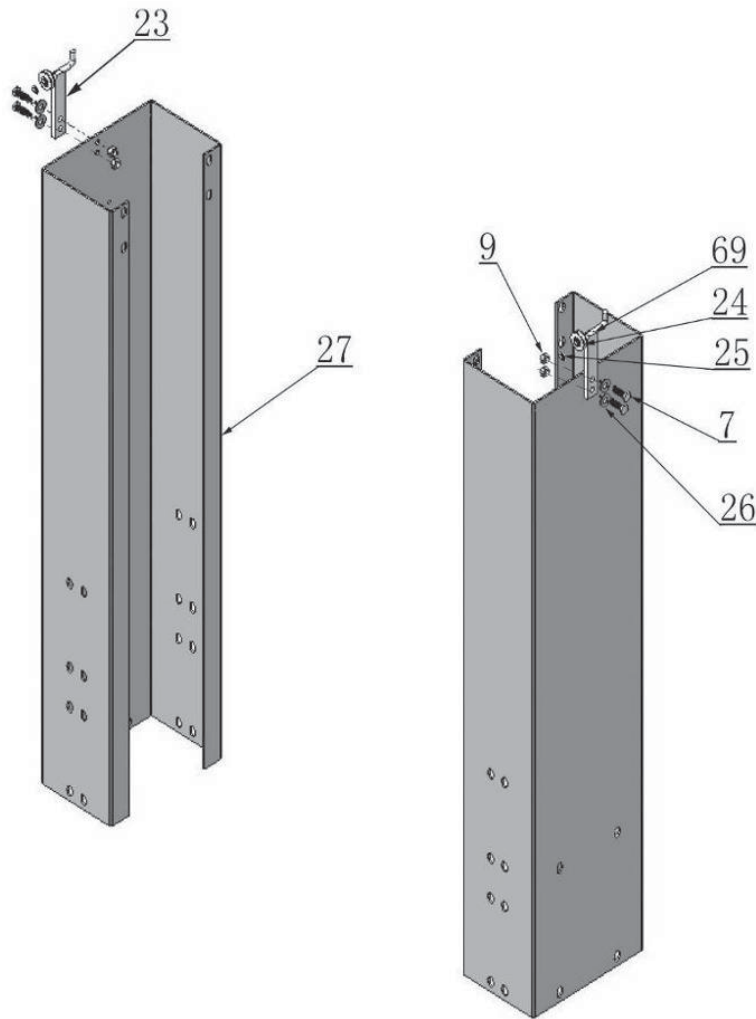


Fig. 12

## E. Position the power side column

Lay down two columns on the installation site parallel. Position the power side column according to the actual installation site. Usually, it is suggested to install power side column on the front-right side from which vehicles are driven to the lift. This lift is designed with 2-Section columns. Adjust the height according to the ceiling height and connect the inner and outer columns.

1. When the ceiling height is less than (151 1/2") for PV-9P, (175 5/8") for PV-9HP, connect the outer columns with the upper holes (**See Fig.13**).

2. When the ceiling height is over (151 1/2") for PV-9P, (175 5/8") for PV-9HP, connect the outer columns with the lower holes (See Fig.14).

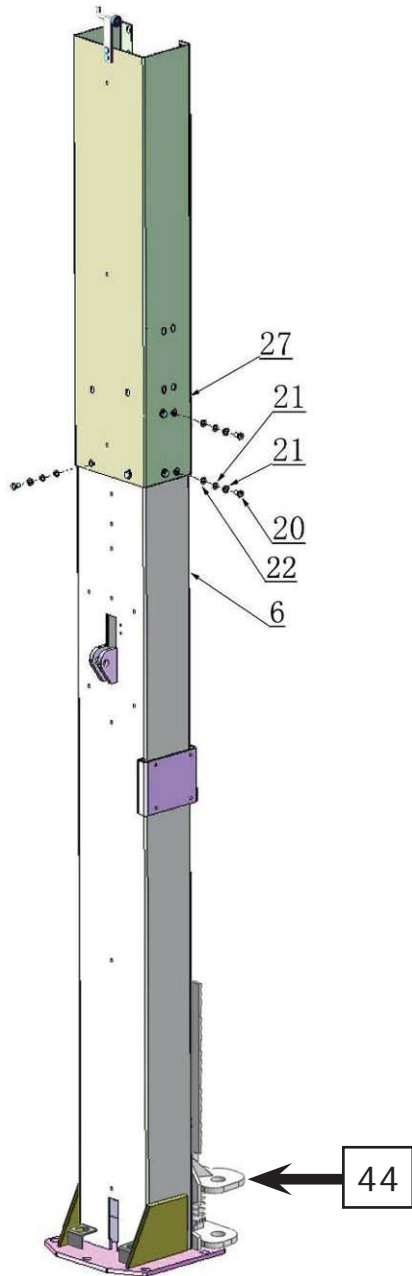


Fig. 13 - Low Setting

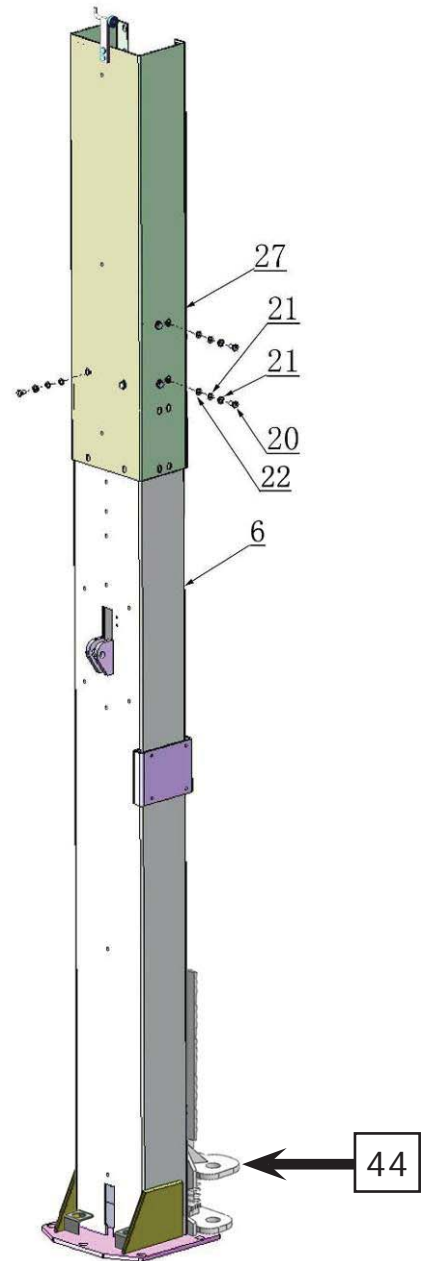
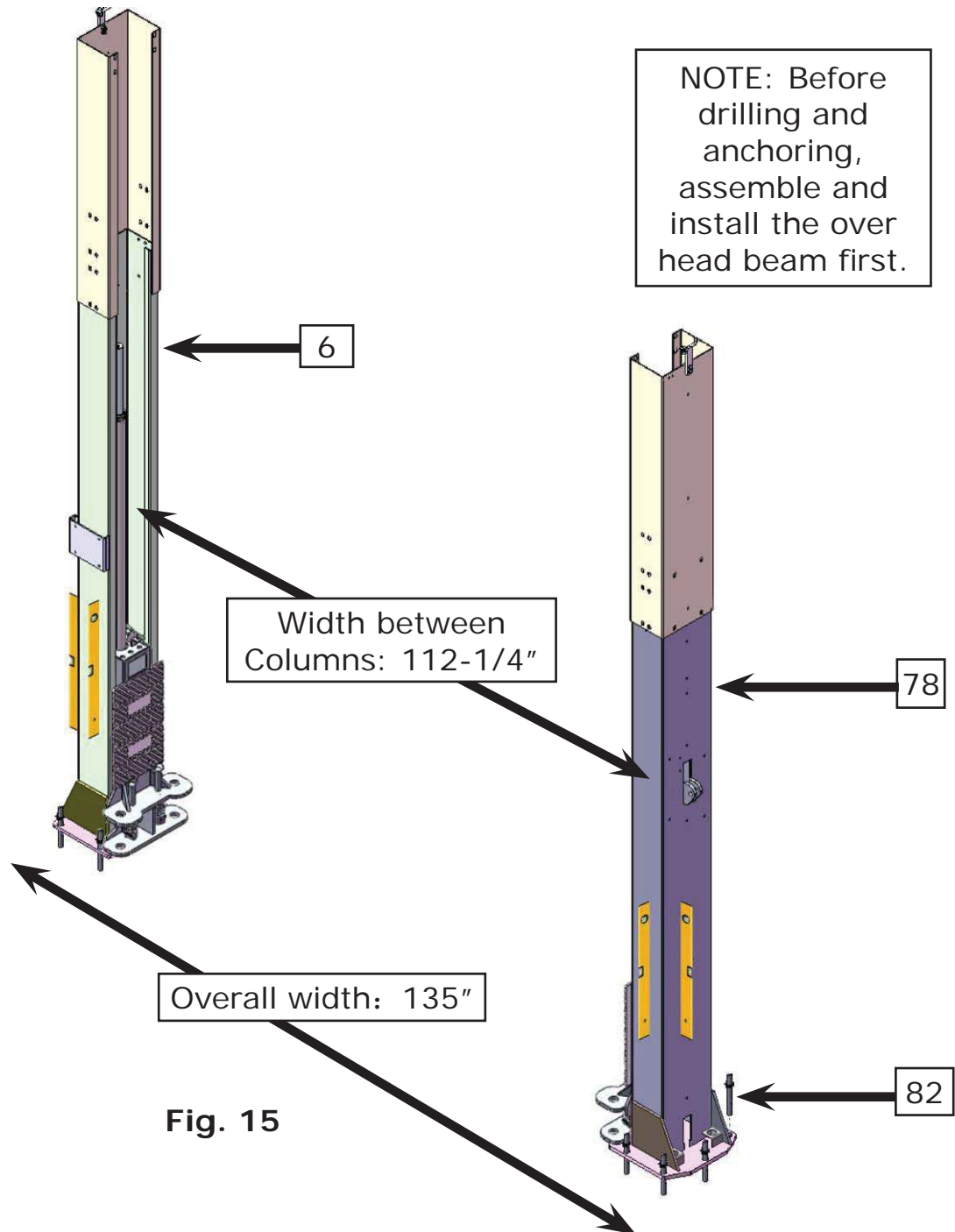


Fig. 14 - High Setting

## F. Position columns / Drill Anchor Holes / Level Columns (See Fig. 15)

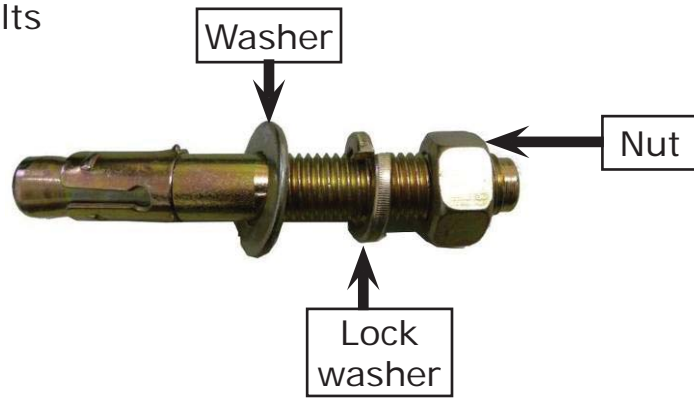
1. Position the columns on the installation layout on the base plate chalk line.



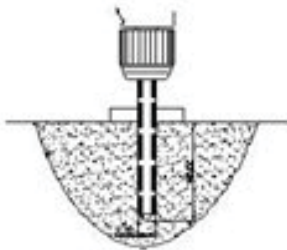
2. Check the columns plumb with a level bar, and adjust with the shims if the columns are not level.



### 3. Prepare the Anchor Bolts



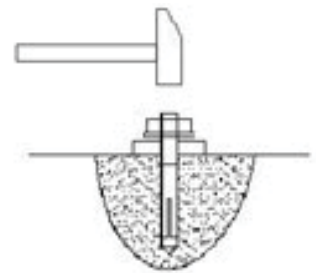
4. Use a rotary hammer drill, drill all the anchor holes and install the anchor bolts. Then tighten the anchor bolts. If the top of the anchor exceeds 2-1/4" above the floor grade, you **DO NOT** have enough embedment. Tighten the anchor bolts between 60 and 86 foot pounds.



Drilling



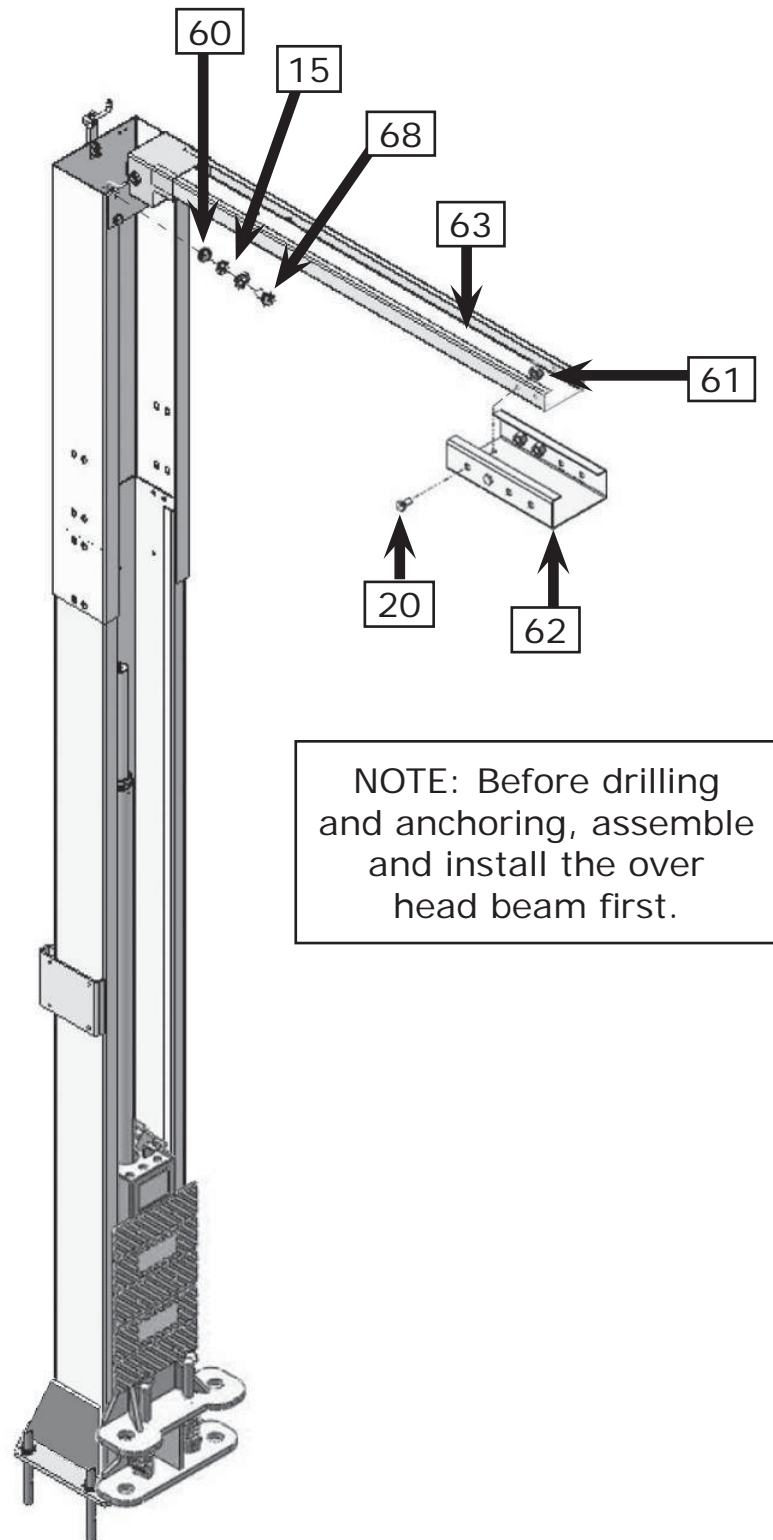
Cleaning



Bolting

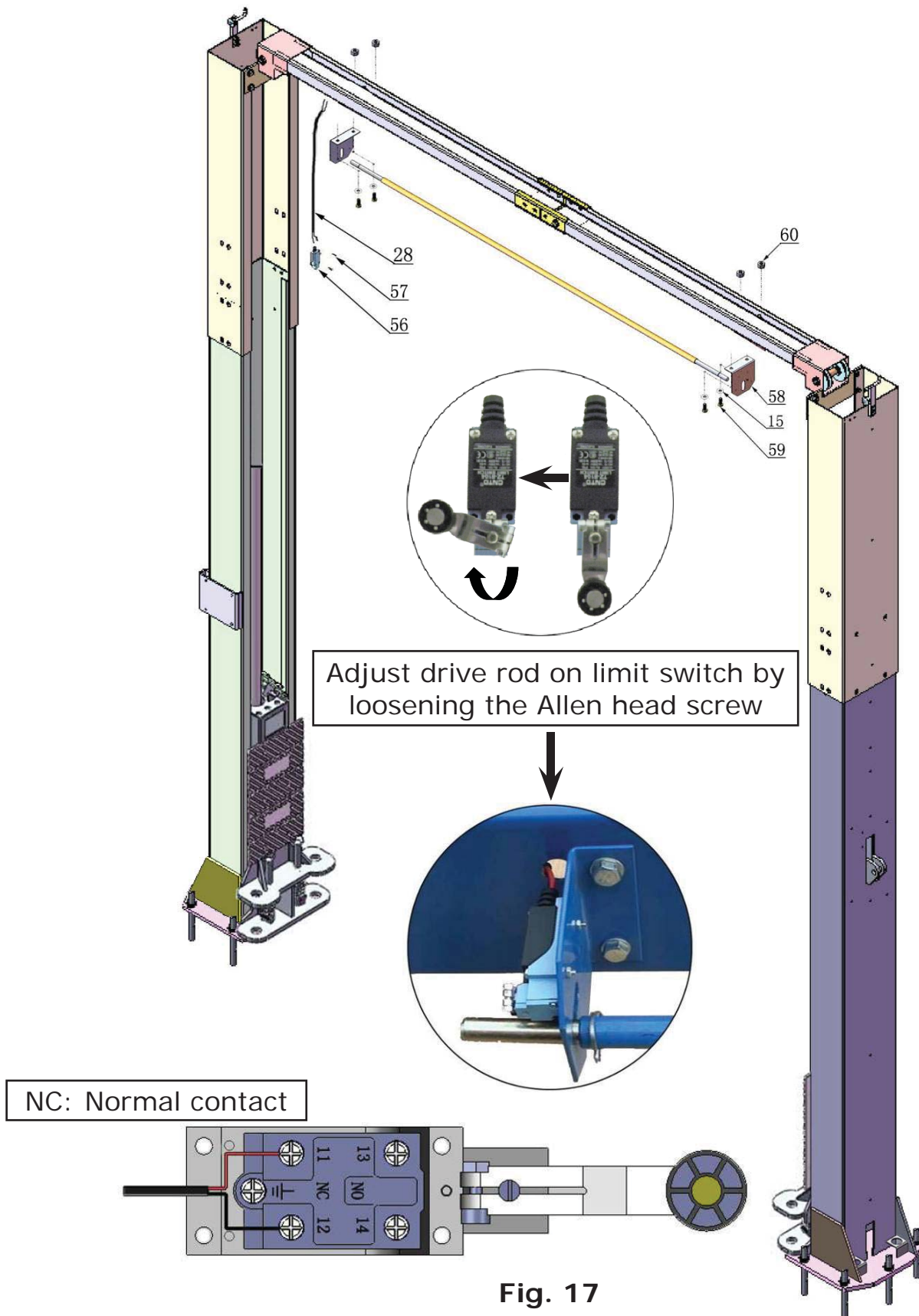
## G. Install overhead top beam

Assemble the over head beam on the ground. With another person and two ladders, walk the overhead beam up and hang it in the hooks. Install hardware and tighten bolts. **(See Fig. 16).**

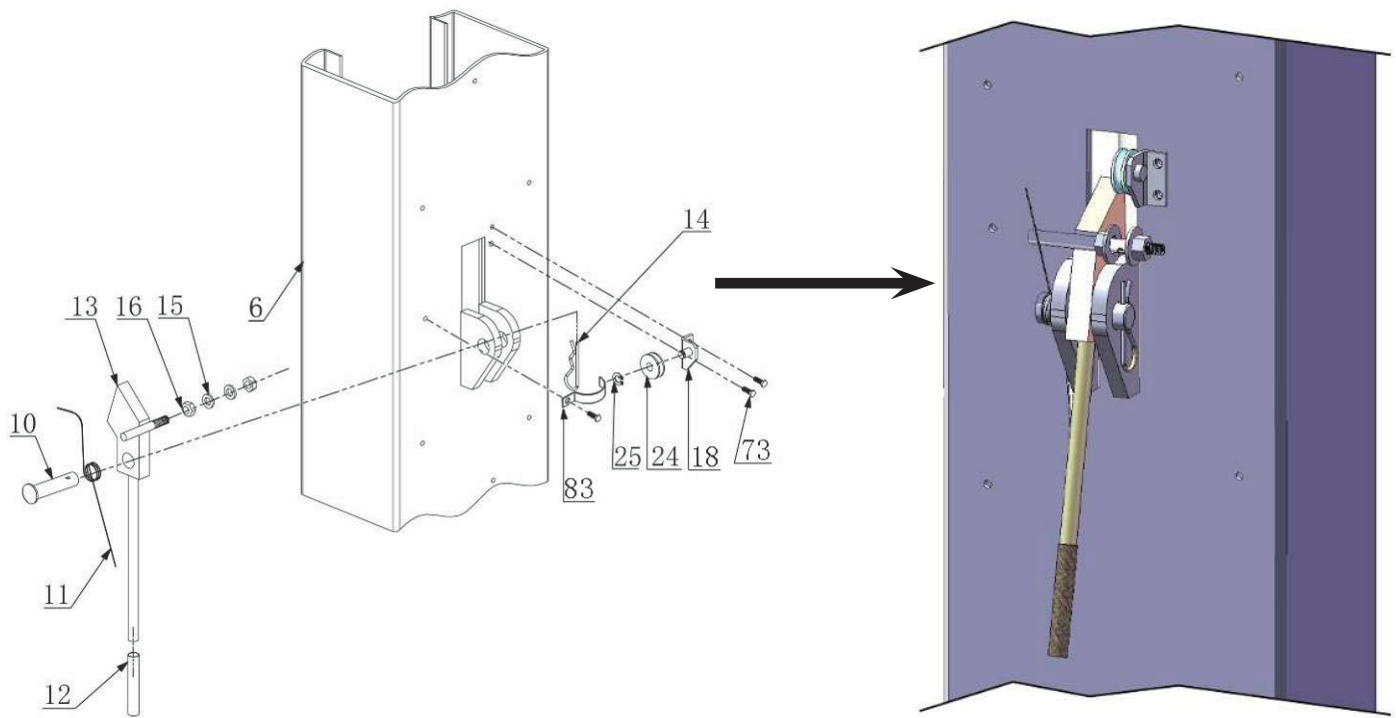


**Fig. 16**

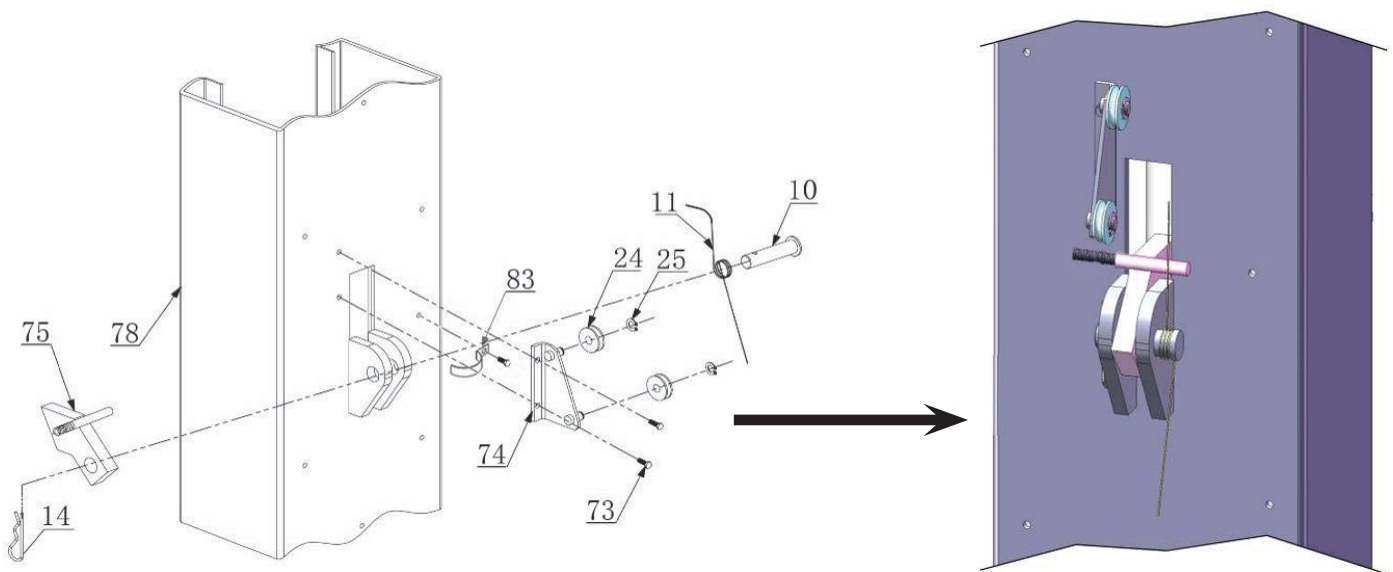
## H. Installing the limit switch control bar and limit switch (See Fig. 17).



# I. Install safety device (See Fig. 18 & Fig. 19).

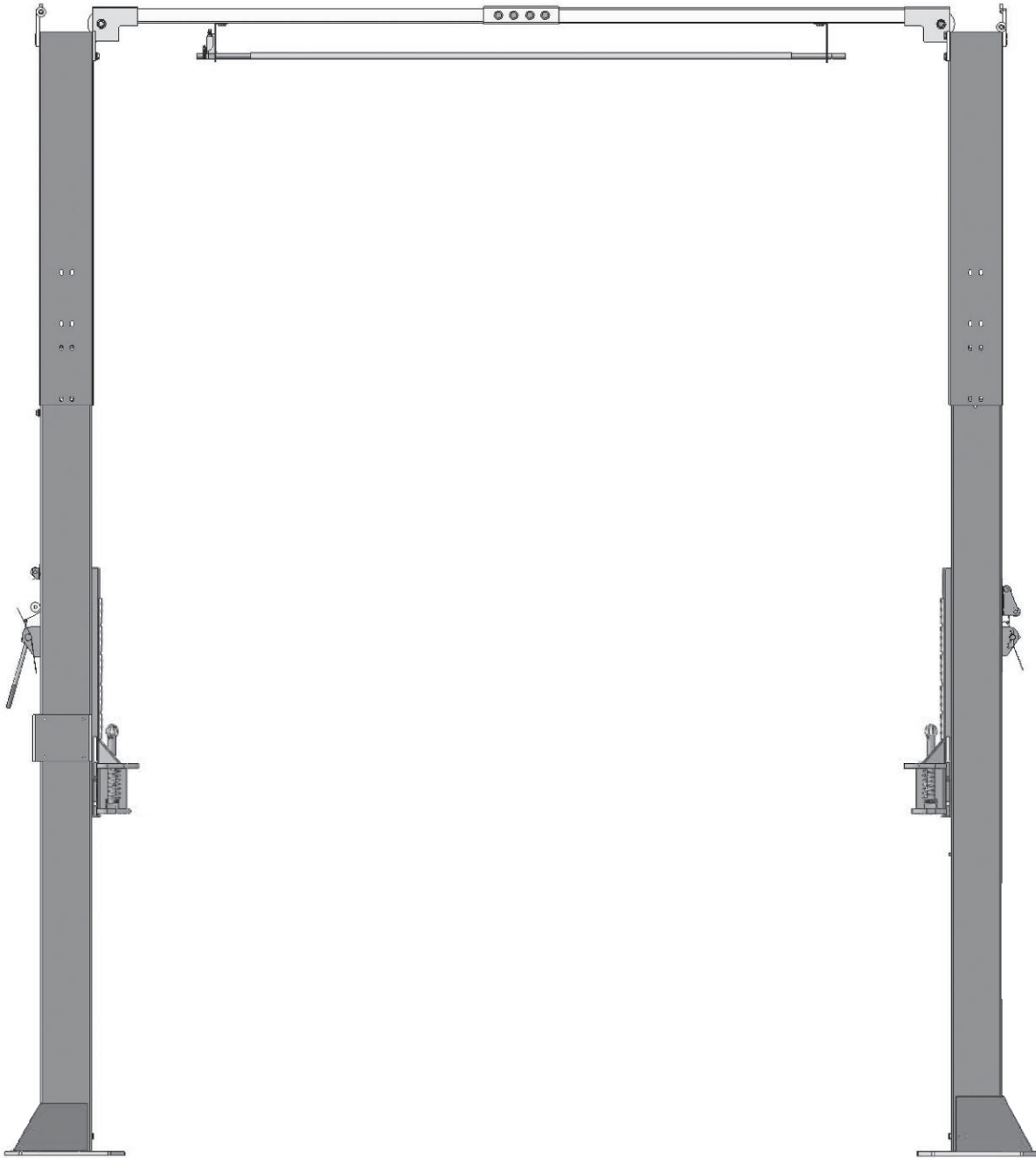


**Fig.18 - Power Side Safety Device**



**Fig. 19 - Offside Safety Device**

**J. Lift the carriages up about 3 feet by hand and lock them at the same level (See Fig. 20).**



**Fig. 20**

## K. Install cables

### 1. Low setting cable connection. (See Fig. 21).

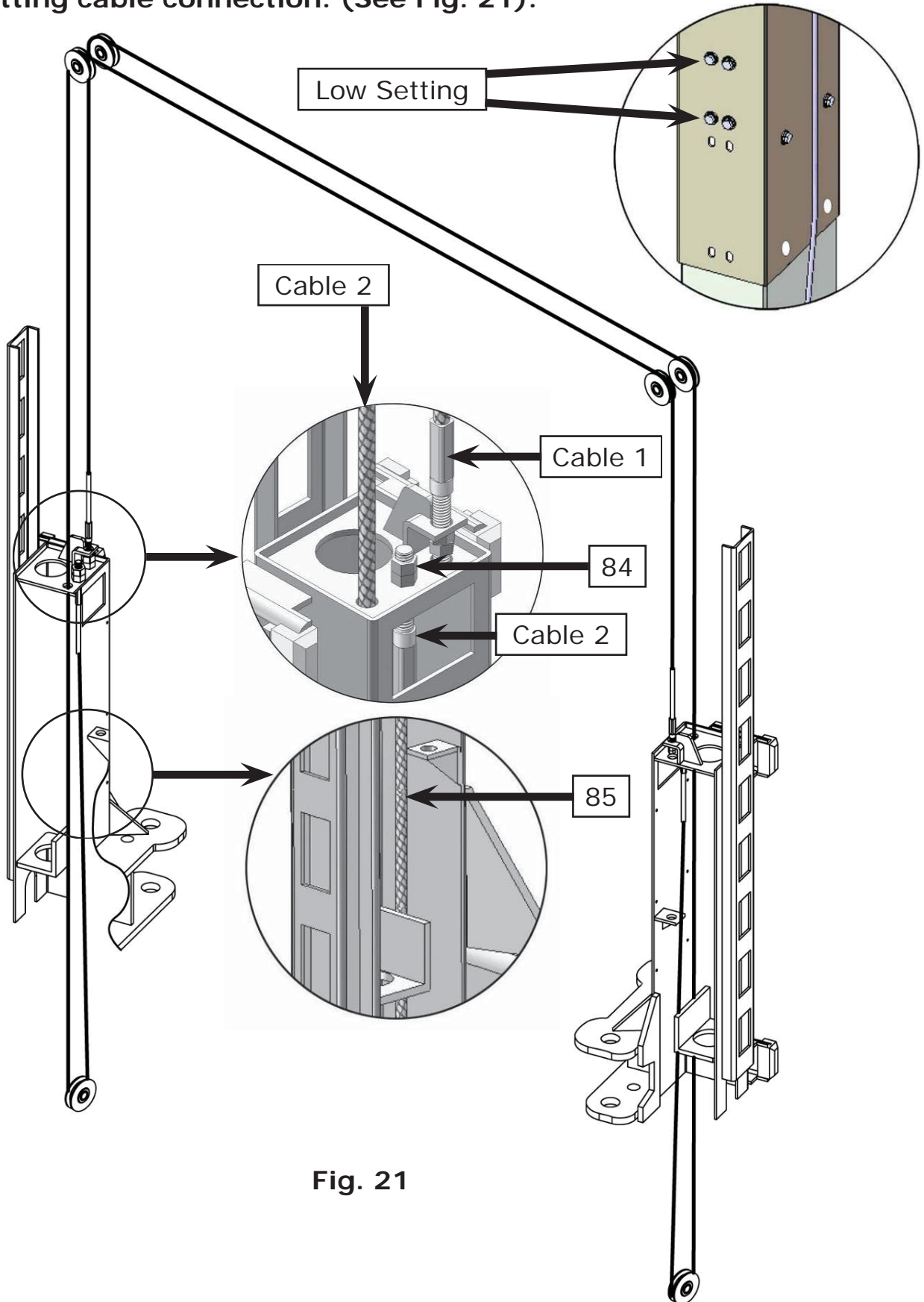
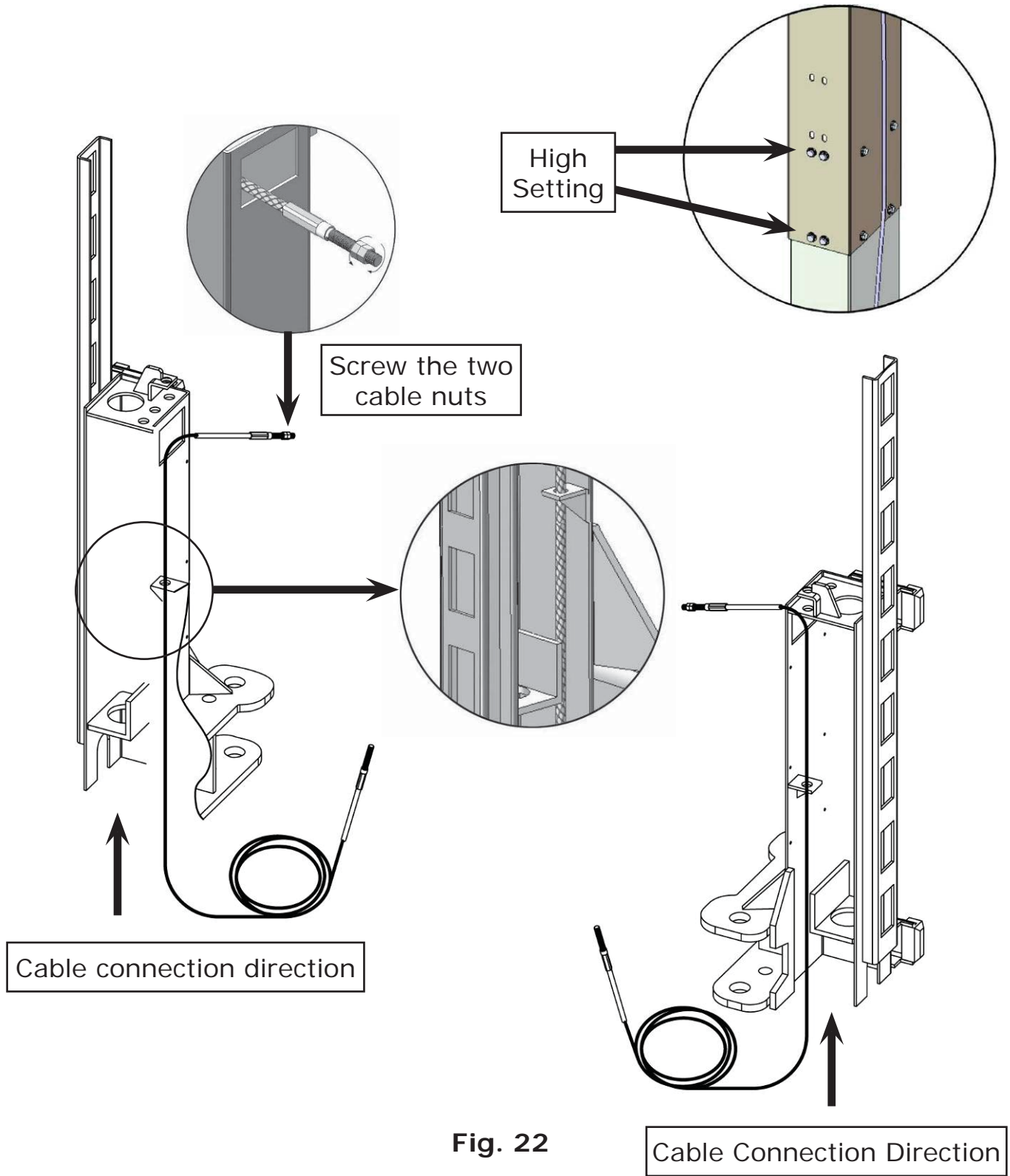


Fig. 21

## 2. High setting cable connection.

2.1. Cable passes through from the bottom of the carriages and is pulled out from the opening in the carriages. Install the two cable nuts (See Fig. 22).





2.2 Connecting cable for high setting (See Fig. 23).

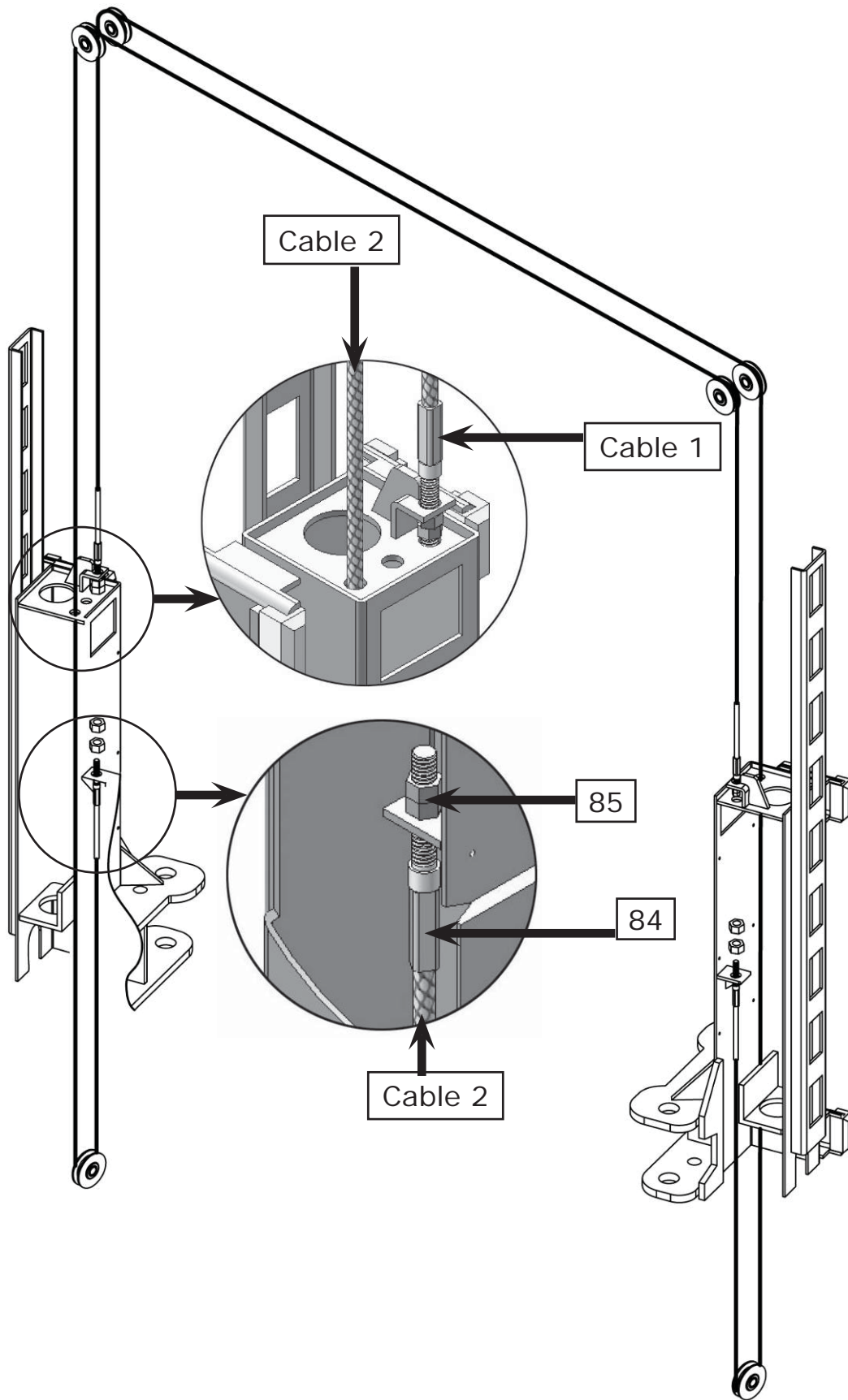


Fig. 23

## L. Install hydraulic power unit and oil hose assembly (See Fig. 24).

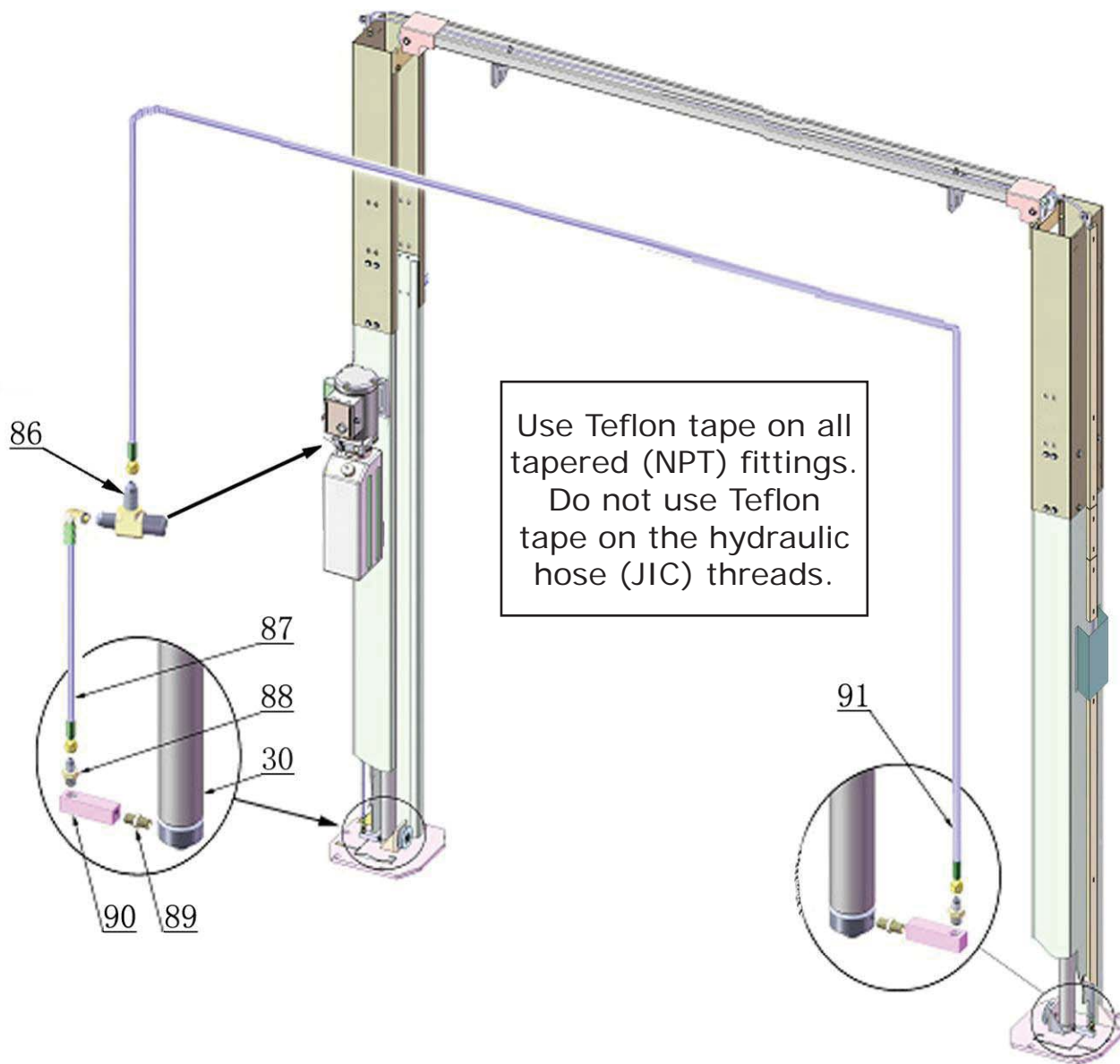


Fig. 24

Tighten all the hydraulic fittings, and fill the reservoir with approximately 3 gallons of hydraulic oil.

**Note: In consideration of Hydraulic Power Unit's durability and keeping the equipment running in good condition, please use Hydraulic Oil AW32.**

# M. Install safety cable (See Fig. 25)

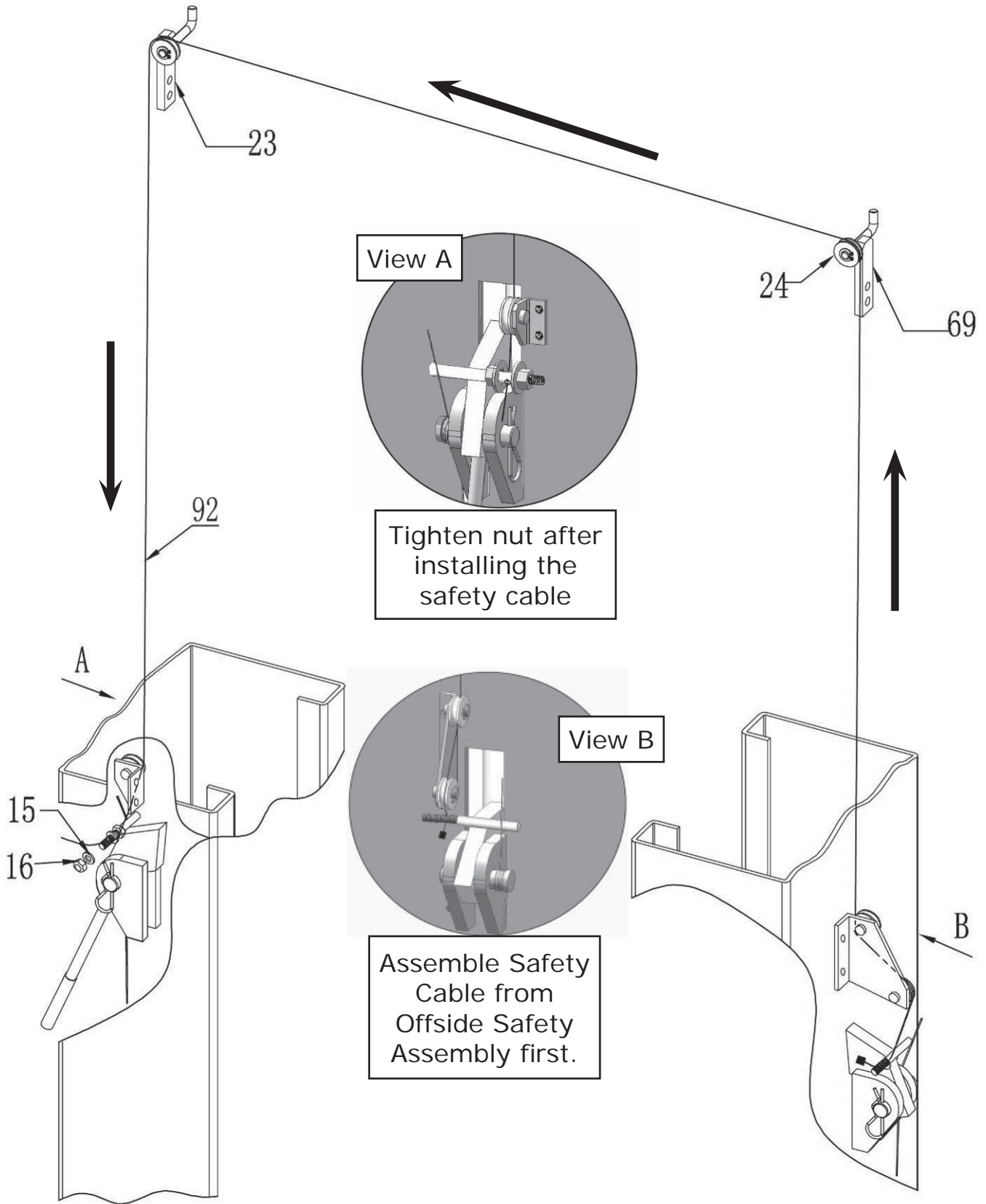


Fig. 25

## N. Oil Hose & Protective Covers

1. Install Oil Hose.

**Note:** Don't cross the oil hose and safety (See Fig. 26 & Fig. 27).

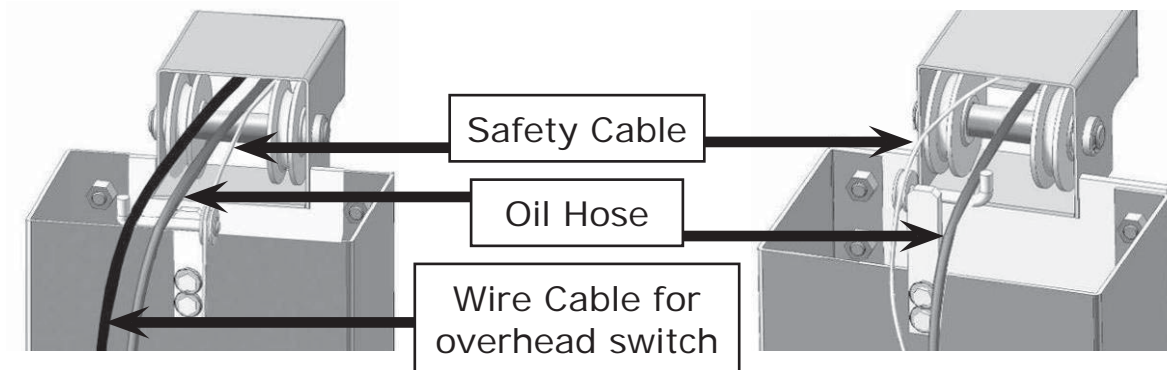
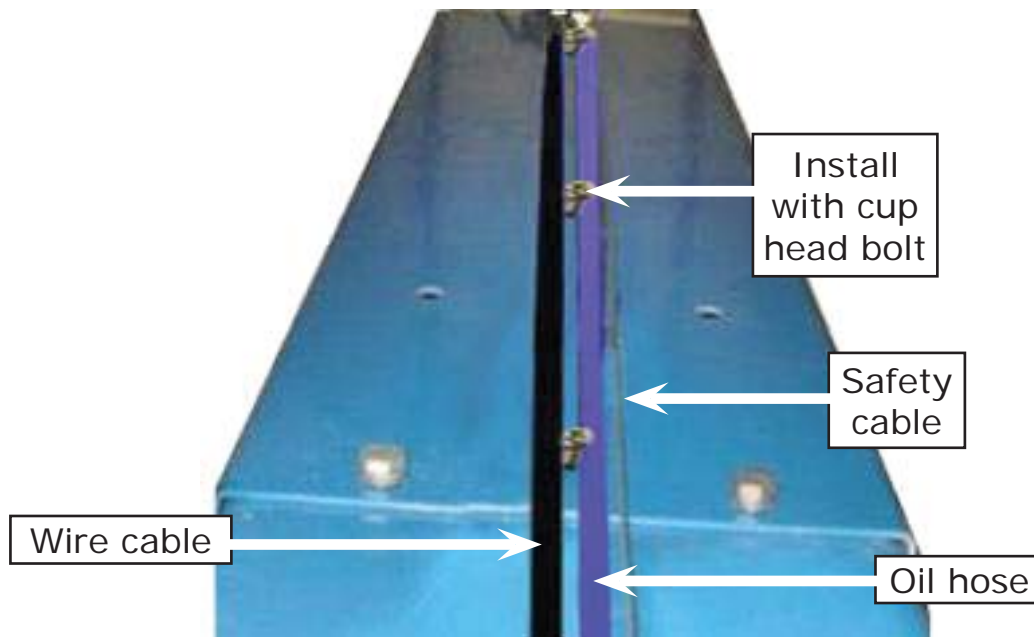


Fig. 26 - Power side Safety Device

Fig. 27 - Off side Safety Device

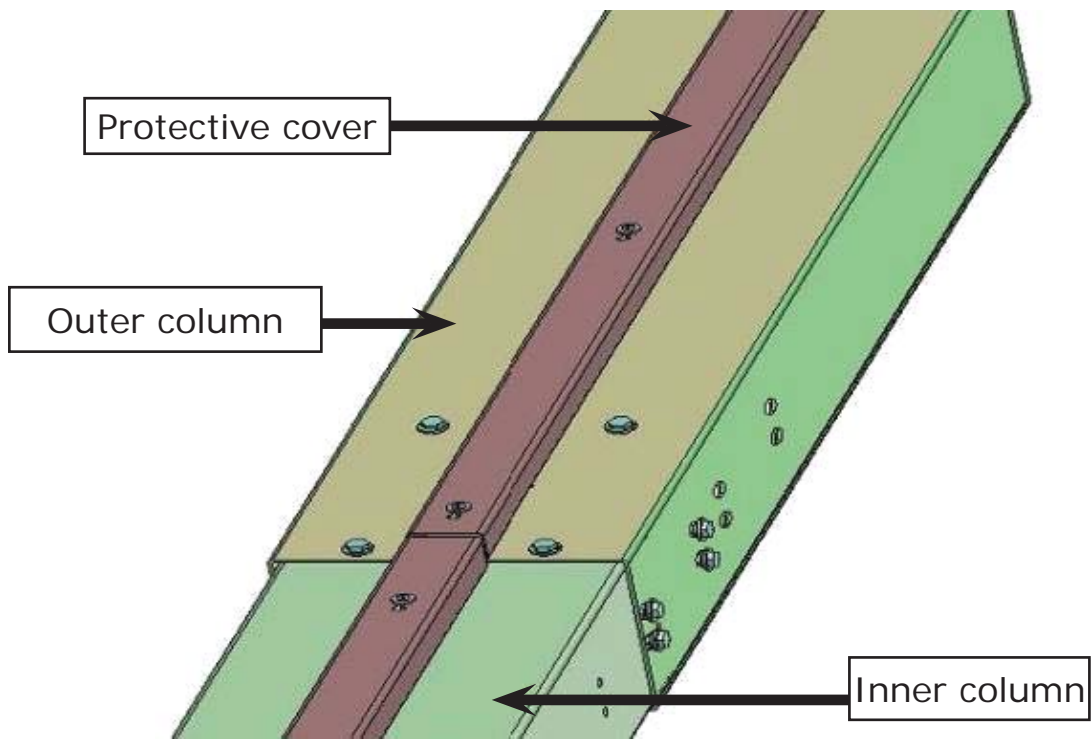
2. Install safety cable, oil hose and protective cover (See Fig. 28 & Fig. 29 & Fig. 30).

**Note:** Install the protective cover on the outer column with M6\*35 cup head bolt, Install the protective cover on the inner column with M6\*40 cup head bolt.



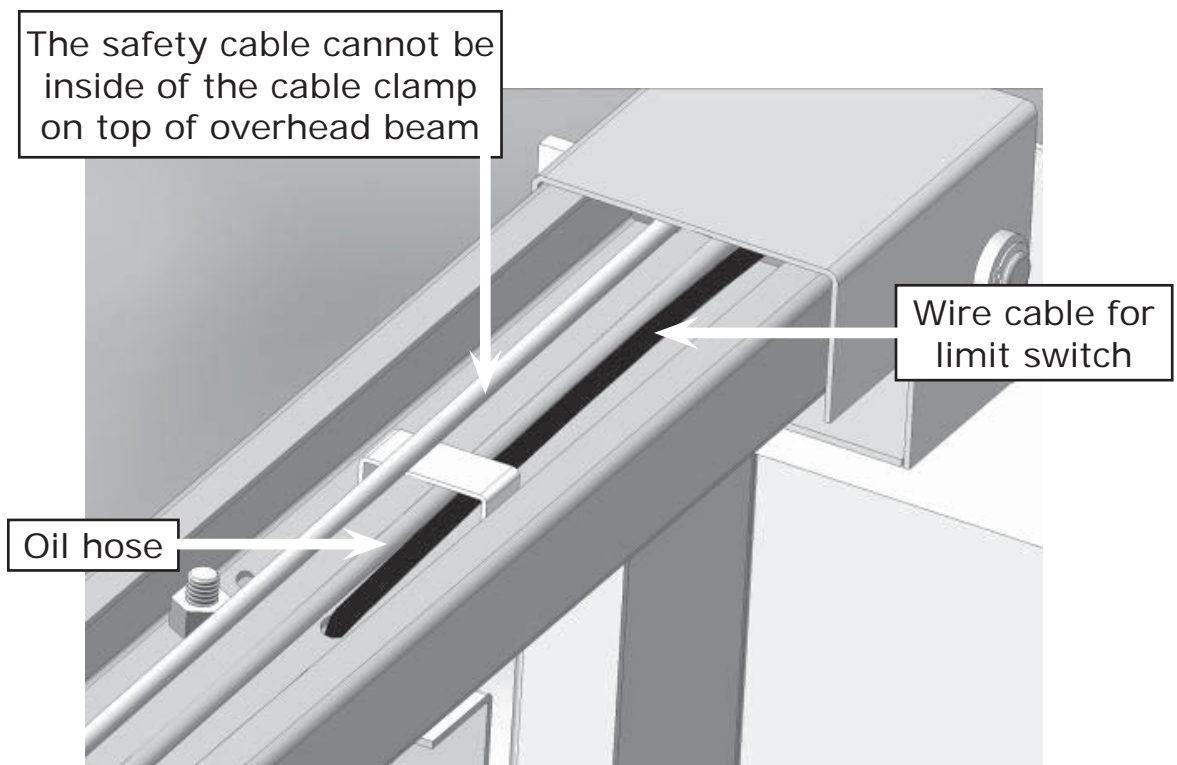
Before installing the wire protective cover

Fig. 28



After installing the wire protective cover

**Fig. 29**



**Fig. 30**



## O. Install lifting arms and adjust the arm locks.

1. Install the lifting arms (See Fig. 31).
2. Lower the carriages down to the lowest position. Use the 8mm Allen head wrench to loosen the Allen bolt (See Fig. 32).

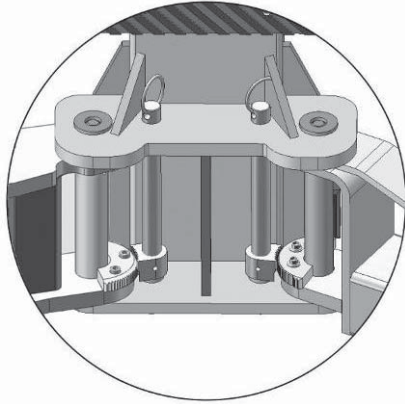


Fig. 31

Use the 8mm  
Allen Head  
Wrench to  
loosen the  
Socket Bolt

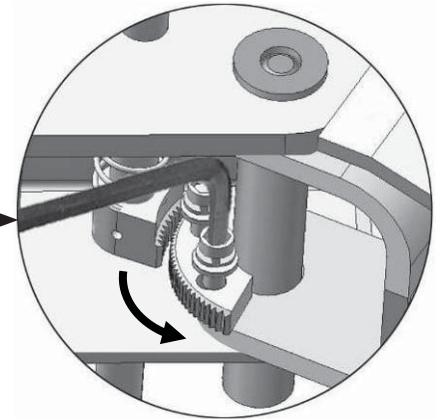


Fig. 32

3. Adjust the arm lock as direction of arrow (See Fig. 33)
4. Adjust moon gear and arm lock so they mesh well. Then tighten the Allen bolts of arm lock (See Fig. 34).

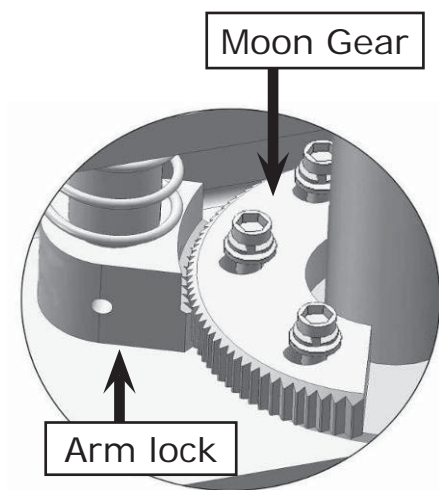


Fig. 33

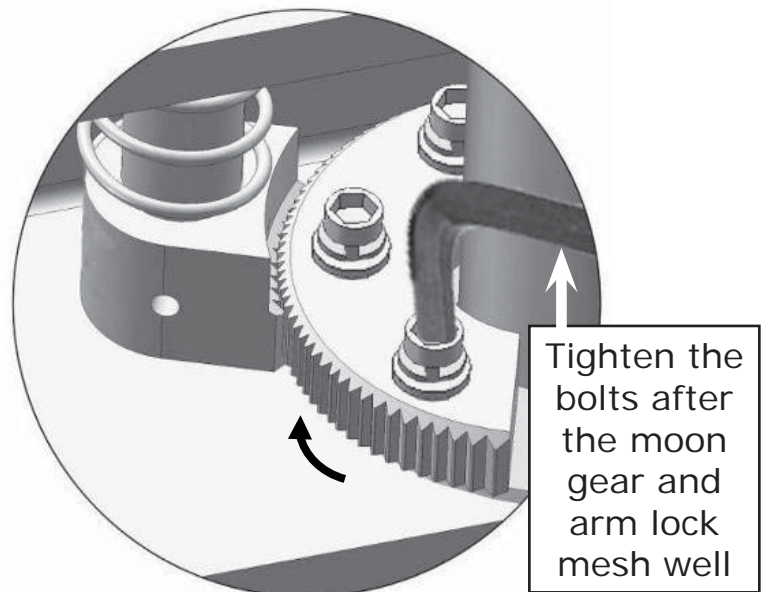


Fig. 34

## P. Install electrical system

Connect the power source according to the data plate on the Power Unit.

**Remove the short “Pig Tail” wire connected to the AC contactor terminals. This wire was used to test the motor after production.**

### ATLAS Single phase motor

**Please Note: This motor is powered by Alternating Current and the terminals on the AC contactor are not wire color specific. There are no positive or negative terminals.**

1. Connect the two power supply (**incoming**) wires (**black & white**) to terminals on the AC contactor marked **L2 & L3** (See Figure 35).
2. Connect the two motor wires to terminals on the AC contactor marked **T2, T3**. **These wires are already connected from the factory.**
3. Connect the short wire **A2** to **L3** on the AC contactor. **This wire is already connected from the factory.**
4. Remove the **entire** wire that connects from the **“UP” button** to **A1** on the AC contactor.
5. Connect one of the wires (**does not matter which one**) on the Limit Switch to the **“UP” button** and connect the remaining Limit Switch wire to terminal **A1** on the AC contactor.

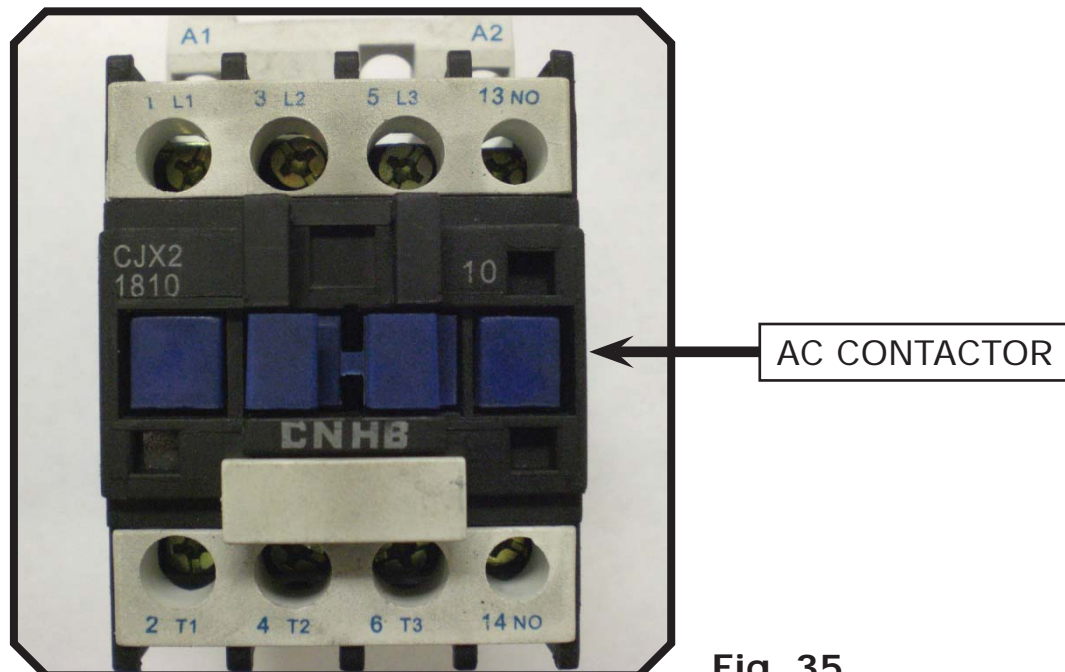


Fig. 35



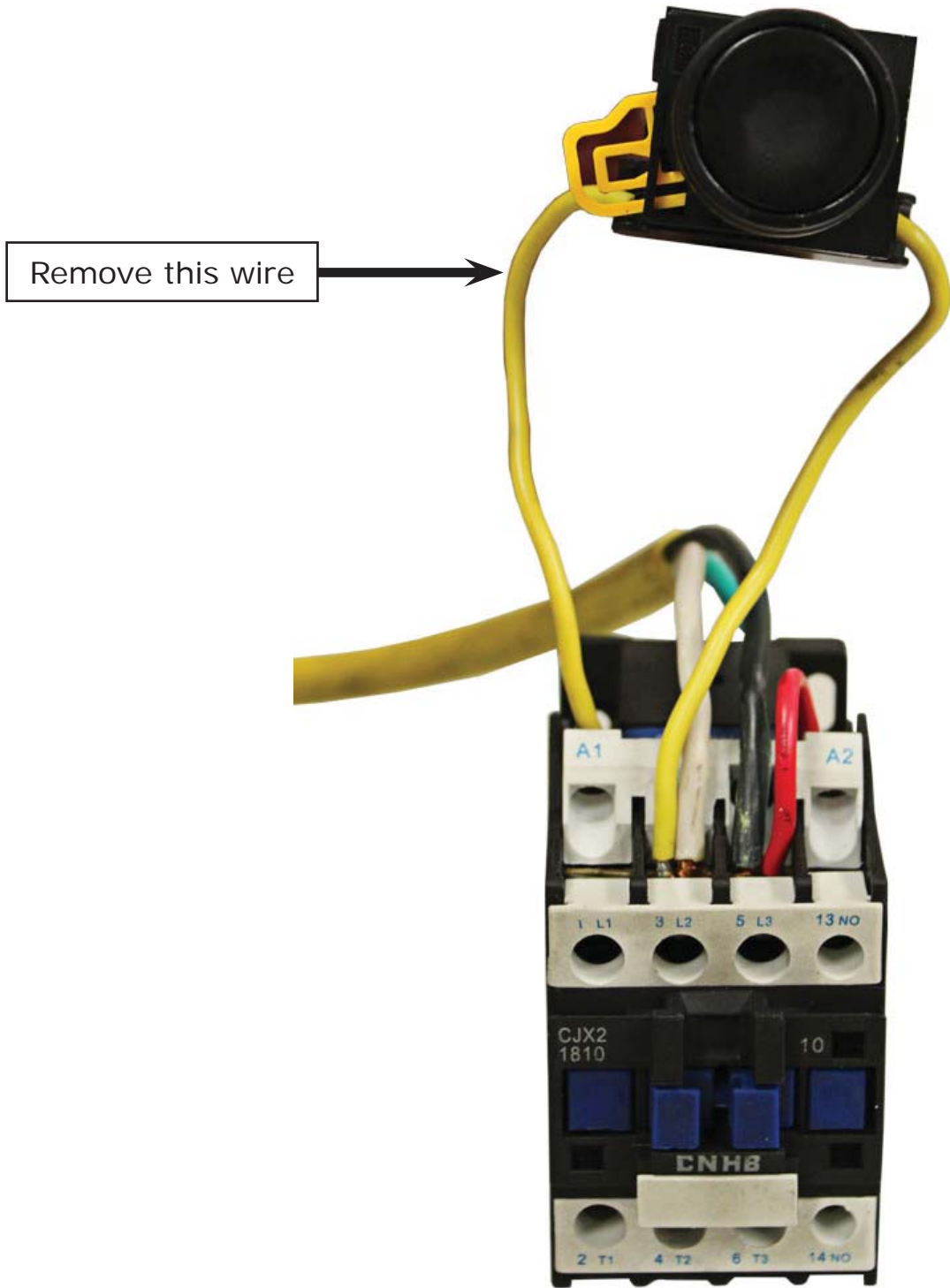


Fig. 36

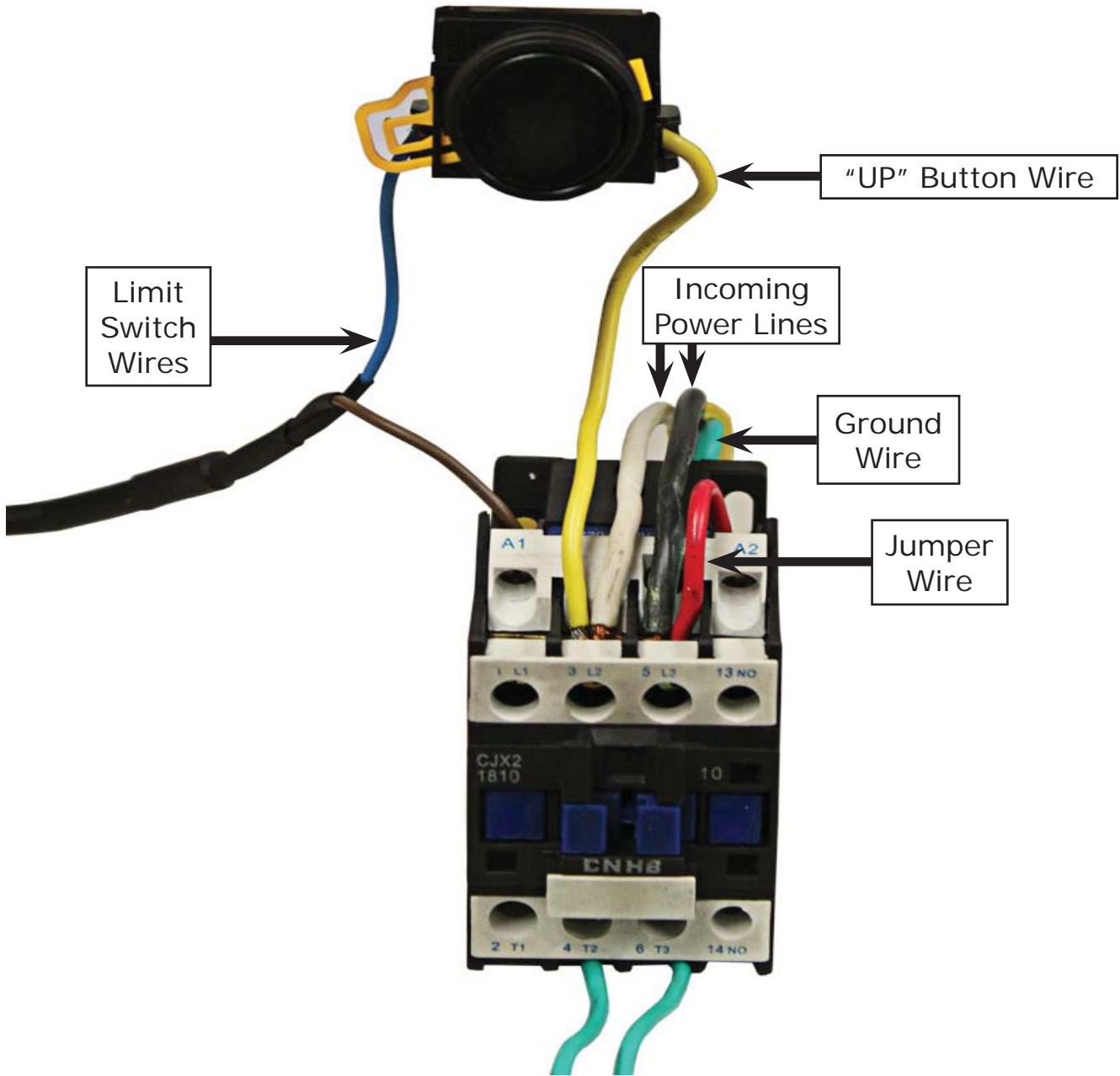


Fig. 37

# Exploded View

## Model PV-9P & PV-9HP

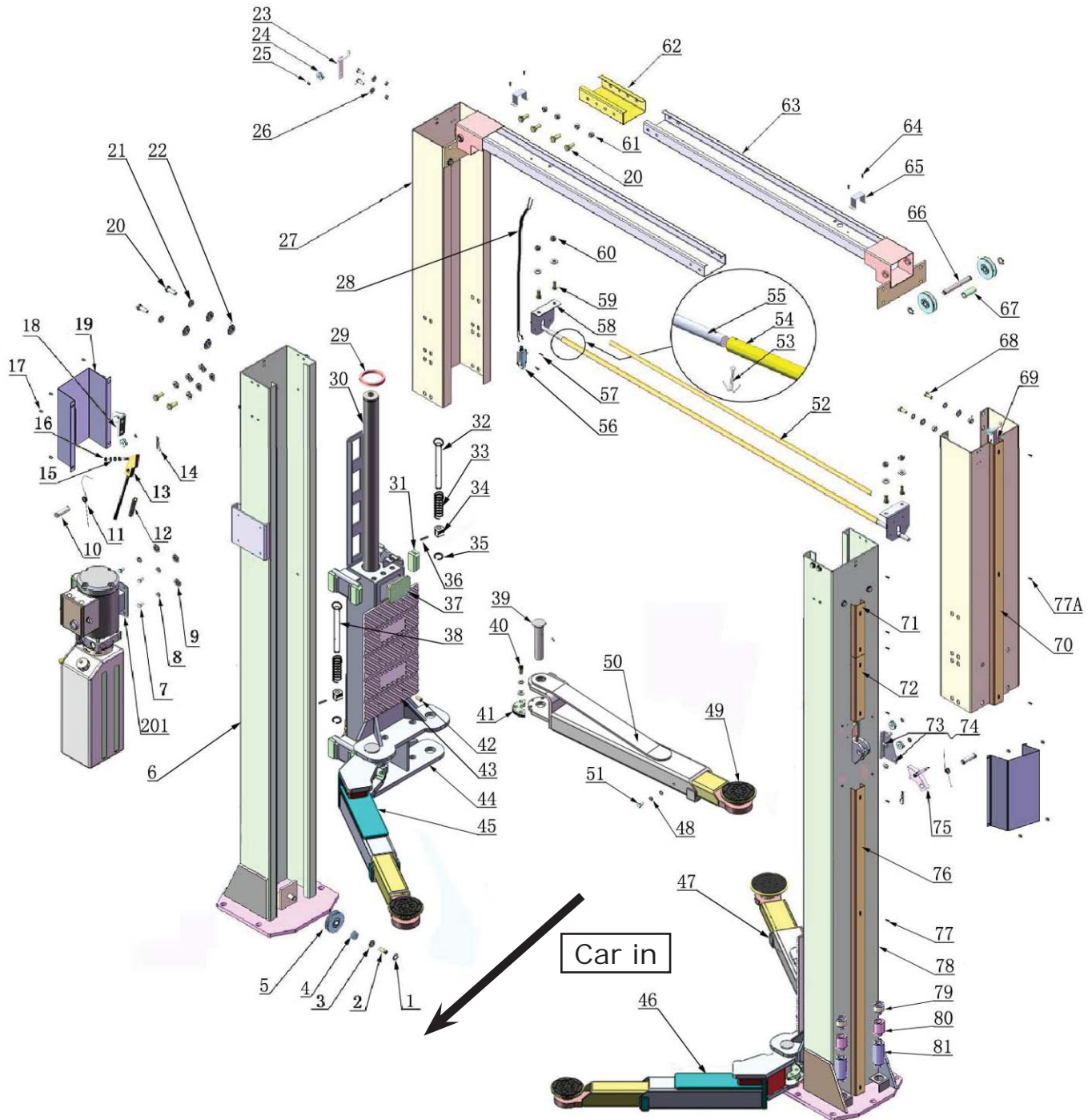


Fig. 38

# Cylinders

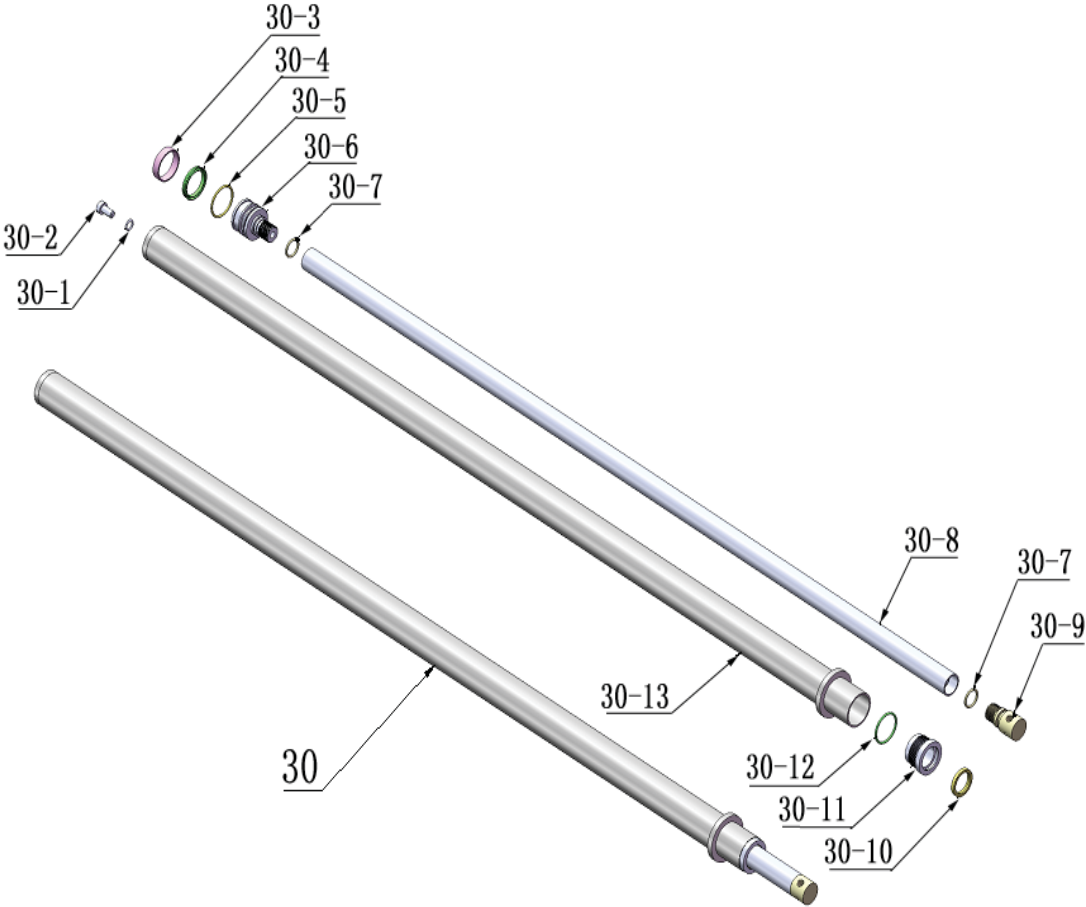


Fig. 39

# ATLAS MANUAL POWER UNIT

220V/60HZ/1 phase

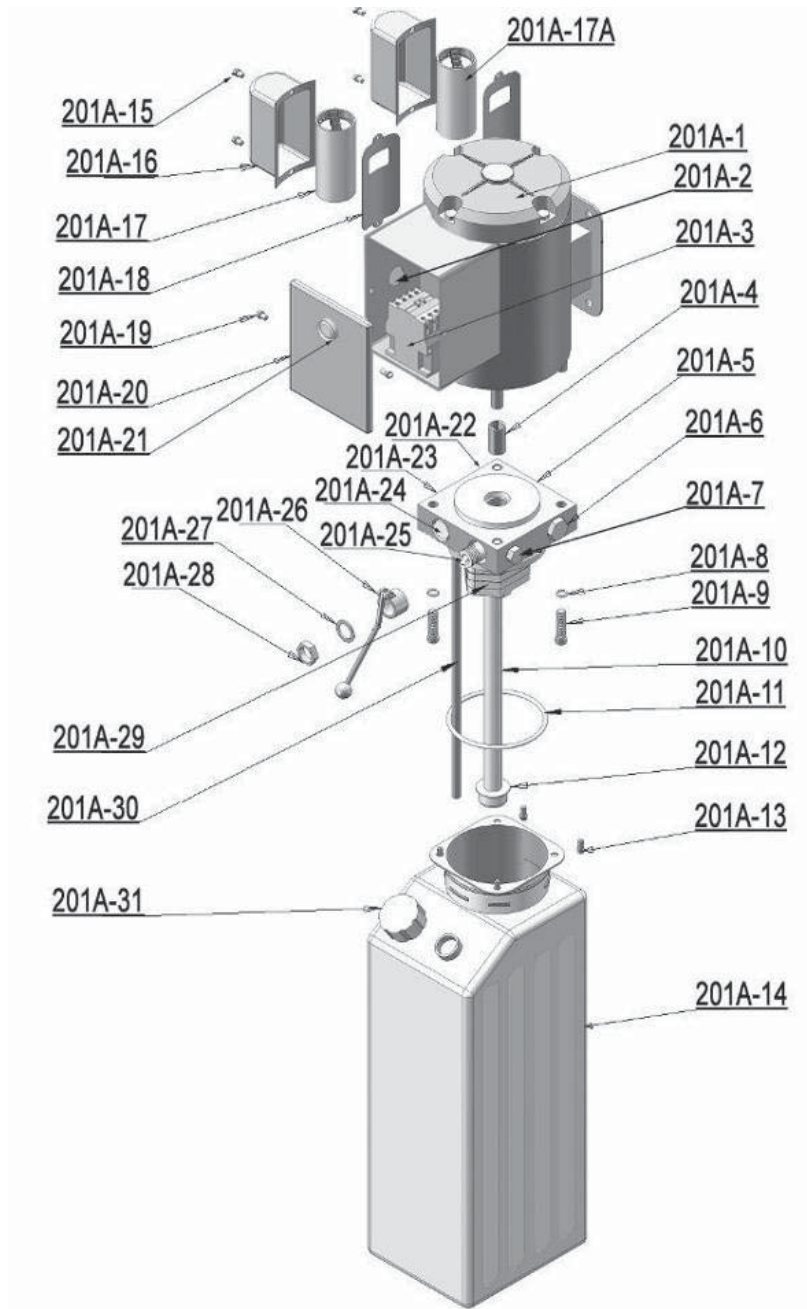


Fig. 40

## Illustration of valves for ATLAS hydraulic power unit

ATLAS manual power unit, 220V/60HZ, Single phase (See Fig. 41)

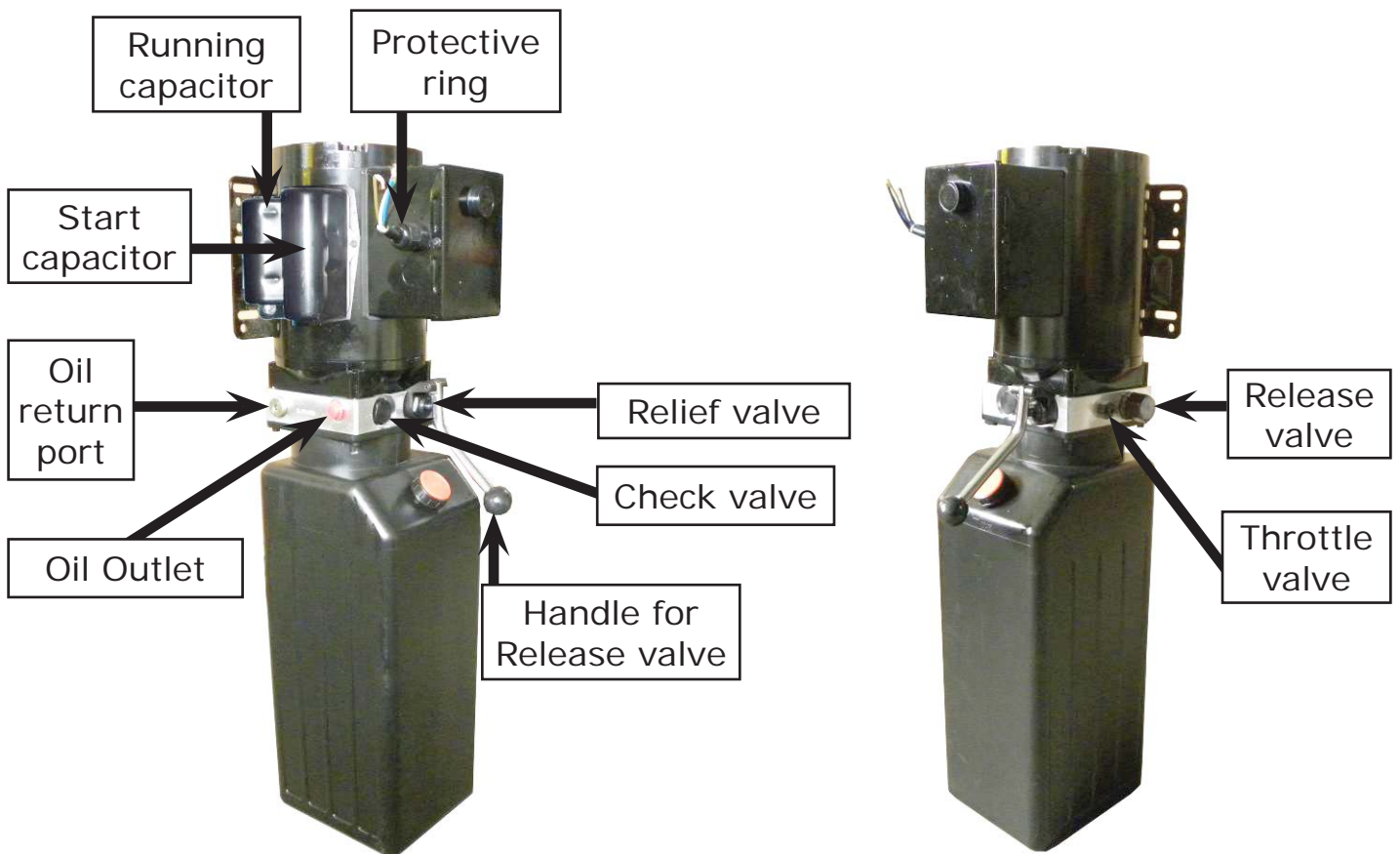


Fig. 41



# Test Run

---

## 1. Adjust the equalizing cables (See Fig. 42)

Use wrench to hold the cable fitting, meanwhile use a ratchet to tighten the cable nut. Make sure the cables have the same tension so the two carriages lift at the same time. Replace the covers on the carriages.

**If the carriages do not lift at the same time, tighten the cable nut on the lower of the two carriages.**

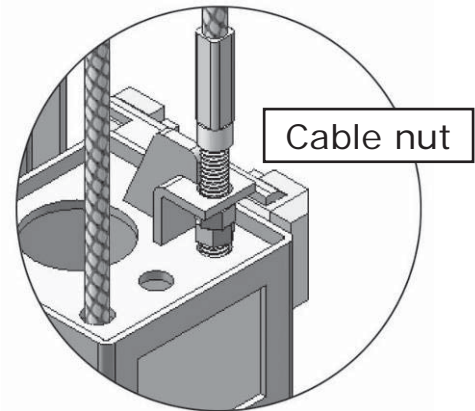


Fig. 42

## 2. Adjust Safety Cable

Lift the carriages and lock at the same height, pull the safety cable and then release a little, and then tighten the cable nuts. Make sure the safety locks click at the same time.

## 3. Bleeding air

This hydraulic system is designed to bleed air by loosening the bleeding screw. Lift the carriages to about 12 inches and loosen the bleeding plug. Lower the lift until fluid comes out. Tighten the screws after bleeding (See Fig. 43).

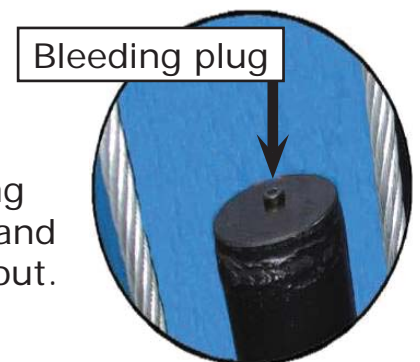
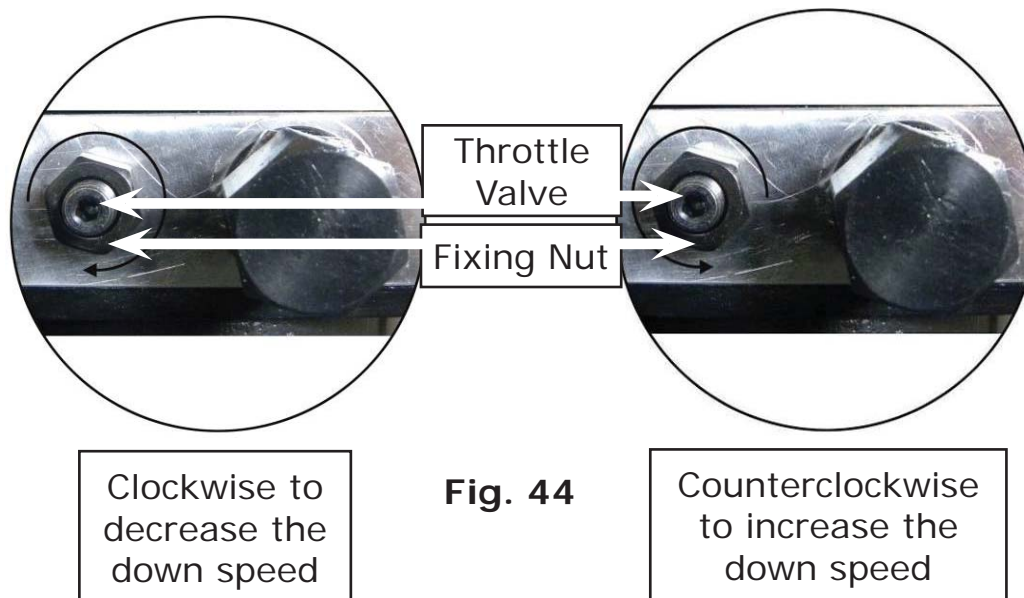


Fig. 43

## 4. Adjust the lower speed (Only for ATLAS power unit) (Adjust with a load on the lift)

You can adjust the lowering speed of the lift if necessary: Loosen the locking nut on the throttle valve, and then turn the throttle valve clockwise to decrease the lowering speed, or counterclockwise to increase the lowering speed. Do not forget to tighten the locking nut after the lower speed adjustment has been completed.



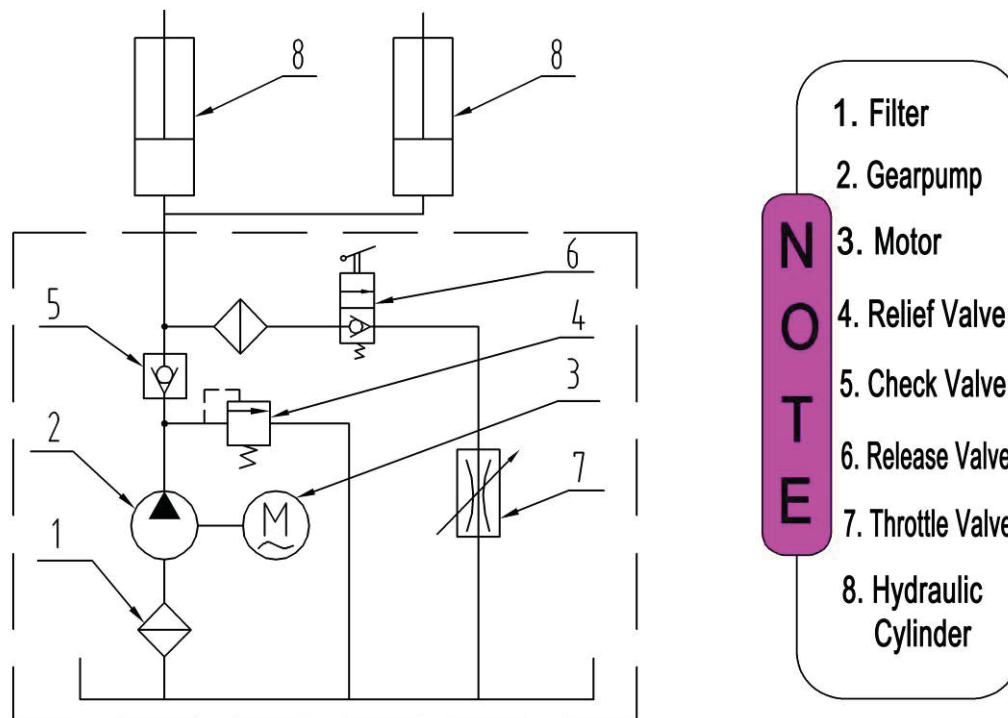


**Fig. 44**

### 5. Test with load

After finishing the above adjustment test run the lift with a load. Run the lift in the low position several times. Run the lift to the top completely.

**NOTE: If the lift vibrates on the way up with a load, lubricate all pulley shafts and wear blocks. If the lift vibrates on the way down, the cylinders need to be bled.**



**Fig. 45 - Hydraulic System**

# Operation Instructions

---

Please read the safety tips carefully before operating the lift

## To lift vehicle

1. Keep the lift area free of clutter;
2. Position lift arms to the lowest position;
3. Open lift arms;
4. Position vehicle between columns;
5. Move arms to the vehicle's lifting points;

**Note: The four lift arms must make contact at the same with the vehicle's lifting points and both axles must rise off of the ground at the same time.**

6. Press the **UP** button until the lift pads contact underside of vehicle. Check to make sure vehicle is secure;
7. Continue to raise the lift slowly to the desired working height, ensuring the balance of vehicle; Push lowering handle to lower lift onto the nearest locks. The vehicle is ready to repair. **Note: The lift must always be on the safety locks.**

## To lower vehicle

1. Keep the lift area free of clutter;
2. Press the button of **UP** to raise the vehicle slightly, and then release the safety device, lower vehicle by pushing lowering handle.
3. Open the arms and position them to the shortest length.
4. Drive away the vehicle.

# Maintenance Schedule

---

## Monthly:

1. Re-torque the anchor bolts to 65-86 Ft Lbs;
2. Check all connectors, bolts and pins to insure proper mounting;
3. Lubricate cable with lubricant;
4. Make a visual inspection of all hydraulic hoses/lines for possible wear or leakage;
5. Check the condition of the safety lock device;
6. Lubricate all rollers and pins with 90wt. Gear oil or equivalent;

**Note: All anchor bolts should take full torque. If any of the bolts do not function for any reason, DO NOT use the lift until the bolt has been replaced.**

## Every six months:

1. Make a visual inspection of all moving parts for possible wear, interference or damage.
2. Check and adjust as necessary, equalizer tension of the cables to ensure level lifting.
3. Check columns for plumb.
4. Check rubber pads and replace as necessary.
5. Check safety lock device and make sure the condition is suitable.

# Trouble Shooting

TROUBLE	CAUSE	REMEDY
Motor does not run	<ol style="list-style-type: none"> <li>1. Button does not work</li> <li>2. Wiring connections are not in good condition</li> <li>3. Motor burned out</li> <li>4. Height Limit Switch is damaged</li> <li>5. AC contactor burned out</li> </ol>	<ol style="list-style-type: none"> <li>1. Replace button</li> <li>2. Repair all wiring connections</li> <li>3. Repair or replace motor</li> <li>4. Replace the Limit Switch</li> <li>5. Replace AC Contactor</li> </ol>
Motor runs but the lift is not raised	<ol style="list-style-type: none"> <li>1. Motor runs in reverse rotation</li> <li>2. Gear Pump out of operation</li> <li>3. Release Valve in damage</li> <li>4. Relief Valve or Check Valve in damage</li> <li>5. Low oil level</li> </ol>	<ol style="list-style-type: none"> <li>1. Reverse two power wire</li> <li>2. Repair or replace</li> <li>3. Repair or replace</li> <li>4. Repair or replace</li> <li>5. Fill tank</li> </ol>
Lift does not stay up	<ol style="list-style-type: none"> <li>1. Release Valve out of work</li> <li>2. Relief Valve or Check Valve leakage</li> <li>3. Cylinder or Fittings leaks</li> </ol>	Repair or replace
Lift raises slowly	<ol style="list-style-type: none"> <li>1. Oil line is jammed</li> <li>2. Motor running on low voltage</li> <li>3. Oil mixed with air</li> <li>4. Gear Pump leaks</li> <li>5. Overload lifting</li> </ol>	<ol style="list-style-type: none"> <li>1. Clean the oil line</li> <li>2. Check Electrical System</li> <li>3. Fill tank</li> <li>4. Replace Pump</li> <li>5. Check load</li> </ol>
Lift will not lower	<ol style="list-style-type: none"> <li>1. Safety device are in activated</li> <li>2. Release Valve in damage</li> <li>3. Safety cable broken</li> <li>4. Oil system is jammed</li> </ol>	<ol style="list-style-type: none"> <li>1. Release the safeties</li> <li>2. Repair or replace</li> <li>3. Replace</li> <li>4. Clean the oil system</li> </ol>

# PV-9P and PV-9HP Parts List

Item	Part#	Description	Qty.		Note
			PV-9P	PV-9HP	
1	206019	Snap Ring	6	6	
2	206058	Bolt	2	2	
3	206059	Washer	2	2	
4	209057B	Bronze Bush For Pulley	6	6	
5	206020	Pulley	6	6	
6	206001B	Power side Inner Column	1	1	
201	209002	Manual Power Unit	1	1	
7	209003	Hex Bolt	8	8	
8	209004	Rubber Ring	4	4	
9	209005	Nylock Nut	8	8	
10	206002	Safety Pin	2	2	
11	209007A	Safety Spring	2	2	
12	206003	Handle Protective Plastic cushion	1	1	
13	206004	Power side Safety Lock	1	1	
14	209012	Hair Pin	2	2	
15	206006	Washer	22	22	
16	206023A	Hex Nut	2	2	
17	209009	Cup Head Bolt	10	10	
18	206004A	Safety Pulley Bracket	1	1	
19	206081	Safety Cover	2	2	
20	206017	Hex Bolt	28	28	
21	209022	Washer	36	36	
22	209021	Hex nut	20	20	
23	206010	Safety Pulley Bracket	1	1	
24	206009	Plastic Pulley	5	5	
25	209010	Snap Ring	5	5	
26	209033	Washer	4	4	
27	206008	Extension Column	2	0	
	206082		0	2	
28	206015A	Wire Cable	1	0	
	206015B		0	1	
29	209111	Protective Ring For Cylinder	2	2	
30	217056	Hydraulic Cylinder	2	2	
31	206044	Slider Block	16	16	
32	206046A	Arm Lock Bar (right)	2	2	

Item	Part#	Description	Qty.		Note
			PV-9P	PV-9HP	
33	206050A	Spring	4	4	
34	217044	Arm Lock	4	4	
35	206032	Snap Ring	4	4	
36	206036	Hair Pin	4	4	
37	209016	Carriage Plastic Cover	2	2	
38	206046B	Arm Lock Bar (left)	2	2	
39	217047	Arm Pin	4	4	
40	206048	Socket Bolt	12	12	
41	206049	Moon Gear	4	4	
42	209019	Screw	12	12	
43	209018	Protective Rubber	2	2	
44	206111	Carriage	2	2	
45	206113	Lifting Arm - Front Right	1	1	
45A	206117	Outer Arm - Front Right	1	1	
45B	206118	Inner Arm - Front Right	1	1	
46	206112	Lifting Arm - Front Left	1	1	
46A	206119	Outer Arm - Front Left	1	1	
46B	206118	Inner Arm - Front Left	1	1	
47	206078B	Lifting Arm - Rear Left	1	1	
47A	206094A	Outer Arm - Rear Left	1	1	
47B	203047A	Inner Arm - Rear Left	1	1	
48	209039	Lock Washer	36	36	
49	201046A	Rubber Pad Assy.	4	4	
49A	420138	Socket bolt	4	4	
49B	209134	Rubber Pad	4	4	
49C	680030C	Rubber Pad Frame	4	4	
50	206076B	Lifting Arm - Rear Right	1	1	
50A	206090A	Outer Arm - Rear Right	1	1	
50B	203049A	Inner Arm - Rear Right	1	1	
51	209038	Hex bolt	4	4	
52	206025A	Foam Cushion	1	1	
53	201005	Split Pin	2	2	
54	206025	Control Bar	1	1	
55	206025C	Connecting Pin for Control Bar	2	2	
56	206013	Limit Switch	1	1	
57	206011	Cup Head Bolt	2	2	
58	206042	Control Bar Support Bracket	2	2	
59	206041	Hex Bolt	4	4	
60	206023	Nylock Nut	12	12	

Item	Part#	Description	Qty.		Note
			PV-9P	PV-9HP	
61	209056	Nylock Nut	8	8	
62	206016	Connecting Bracket	1	1	
63	206018	Top Beam W/Bracket	2	2	
64	206028	Cup Head Bolt	4	4	
65	206029	Retainer	2	2	
66	206021	Pin For Pulley	2	2	
67	206022	Top Pulley Tube	2	2	
68	206024	Hex Bolt	8	8	
69	206010A	Safety Pulley Bracket	1	1	
70	206085	Protective cover L=1240	2	0	
	206086	Protective cover L=1850	0	2	
71	206084	Protective cover L=200	2	2	
72	206083	Protective cover L=385	2	2	
73	206008A	Hex Bolt	4	4	
74	206008C	Safety Pulley Bracket	1	1	
75	206026	Offside Safety Lock	1	1	
76	206080	Protective cover L=1565	2	2	
77	206079	Cup head bolt	14	14	
77A	206110	Cup head bolt	6	6	
78	206030B	Offside Inner column	1	1	
79	209051B	Extension adaptor (1.5")	4	4	
80	209052B	Extension adaptor (2.5")	4	4	
81	209053B	Extension adaptor (5")	4	4	
82	209059	Anchor Bolt	10	10	
83	217048	Retainer	2	2	
84	209066	Hex nut	8	8	
85	206064A	Cable	2	0	
	206064B		0	2	
86	206073	T- Fitting For Power Unit	1	1	
87	206074A	Oil Hose	1	1	
88	209064	Straight Fitting	2	2	
89	206062	Straight Fitting	2	2	
90	233009	Pipe Fitting	2	2	
91	206061C	Oil Hose	1	0	
	206061D	Oil Hose	0	1	
92	206065	Safety cable	1	0	
	206065A	Safety cable	0	1	
93	206500A	Parts box	1	0	
	206501A		0	1	



Item.	Part No.	Description	Qty.		Note
			PV-9P	PV-9HP	
<b>Parts For Hydraulic Cylinder</b>					
30-1	209069	O-Ring	2	2	
30-2	209070	Bleeding Plug	2	2	
30-3	209071	Support Ring	2	2	
30-4	209072	Y-Ring	2	2	
30-5	209073	O-Ring	2	2	
30-6	209074	Piston	2	2	
30-7	209075	O-Ring	2	2	
30-8	217076	Piston Rod	2	2	
30-9	209077	Piston Rod Fitting	2	2	
30-10	209078	Dust Ring	2	2	
30-11	209079	Head Cap	2	2	
30-12	209080	O-Ring	2	2	
30-13	209081A	Bore Weldment	2	2	
<b>Parts For ATLAS Manual Power Unit, 220V/60Hz/1phase</b>					
201A-1	209082A	Motor	1	1	
201A-2	209109	Protective Ring	1	1	
201A-3	209112	AC contactor	1	1	
201A-4	209083A	Motor Connecting Shaft	1	1	
201A-5	209084A	Valve Body	1	1	
201A-6	209085A	Relief Valve	1	1	
201A-7	209113	Throttle valve	1	1	
201A-8	209086A	Lock Washer	4	4	
201A-9	209087A	Socket Bolt	4	4	
201A-10	209088A	Inlet Pipe	1	1	
201A-11	209089A	O-Ring	1	1	
201A-12	209090A	Filter	1	1	
201A-13	209091A	Socket bolt	4	4	
201A-14	209092A	Reservoir (10 liter)	1	1	
201A-15	209093A	Cup Head Bolt With Washer	4	4	
201A-16	209094A	Cover of Capacitor	2	2	
201A-17	209095A	Start Capacitor	1	1	
201A-17A	209095B	Running Capacitor	1	1	
201A-18	209096A	Rubber Gasket	2	2	
201A-19	209097A	Cup Head Bolt With Washer	2	2	
201A-20	209098A	Cover of Motor Terminal Box	1	1	
201A-21	209099A	Push Button	1	1	
201A-22	209110A	Oil Return Port	1	1	

Item.	Part No.	Description	Qty.		Note
			PV-9P	PV-9HP	
201A-23	209100A	Oil Outlet	1	1	
201A-24	209105A	Check Valve	1	1	
201A-25	209101A	Release Valve	1	1	
201A-26	209102A	Handle For Release Valve	1	1	
201A-27	209103A	Washer	1	1	
201A-28	209104A	Hex Nut	1	1	
201A-29	209106A	Gear Pump	1	1	
201A-30	209107A	Oil Return Pipe	1	1	
201A-31	209108A	Filler Cap	1	1	

# Warranty

---



**This item** is warranted for five (5) years on structural components, two (2) years on hydraulic cylinders, and one (1) year on electric or air / hydraulic power units from invoice date. Wear items are covered by a 90 day warranty.

This LIMITED warranty policy does **not include a labor** warranty.

**NOTE: ALL WARRANTY CLAIMS MUST BE PRE-APPROVED BY THE MANUFACTURER TO BE VALID.**

The Manufacturer shall repair or replace at their option for this period those parts returned to the factory freight prepaid, which prove after inspection to be defective. This warranty will not apply unless the product is installed, used and maintained in accordance with the Manufacturers installation, operation and maintenance instructions.

This warranty applies to the ORIGINAL purchaser only, and is non-transferable. The warranty covers the products to be free of defects in material and workmanship but, does not cover normal maintenance or adjustments, damage or malfunction caused by: improper handling, installation, abuse, misuse, negligence, carelessness of operation or normal wear and tear. In addition, this warranty does not cover equipment when repairs or alterations have been made or attempted to the Manufacturer's products.

THIS WARRANTY IS EXCLUSIVE AND IS LIEU OF ALL OTHER WARRANTIES EXPRESSED OR IMPLIED INCLUDING ANY IMPLIED WARRANTY OR MERCHANTABILITY OR ANY IMPLIED WARRANTY OF FITNESS FROM A PARTICULAR PURPOSE, AND ALL SUCH IMPLIED WARRANTIES ARE EXPRESSLY EXCLUDED.

THE REMEDIES DESCRIBED ARE EXCLUSIVE AND IN NO EVENT SHALL THE MANUFACTURER, NOR ANY SALES AGENT OR OTHER COMPANY AFFILIATED WITH IT OR THEM, BE LIABLE FOR SPECIAL CONSEQUENTIAL OR INCIDENTAL DAMAGES FOR THE BREACH OF OR DELAY IN PERFORMANCE OF THIS WARRANTY. THIS INCLUDES, BUT IS NOT LIMITED TO, LOSS OF PROFIT, RENTAL OR SUBSTITUTE EQUIPMENT OR OTHER COMMERCIAL LOSS.

**PRICES:** Prices and specifications are subject to change without notice. All orders will be invoiced at prices prevailing at time of shipment. Prices do not include any local, state or federal taxes.

**RETURNS:** Products may not be returned without prior written approval from the Manufacturer.

DUE TO THE COMPETITIVENESS OF THE SELLING PRICE OF THESE LIFTS, THIS WARRANTY POLICY WILL BE STRICTLY ADMINISTERED AND ADHERED TO.