

# 9K0H

**9,000 lb. Capacity  
Two-Post Overhead Lift**



## **INSTALLATION & OPERATION MANUAL**

Revised 9/6/2018

**Read this entire manual before operation begins.**

Record below the following information which is located on the serial number data plate.

Serial No. \_\_\_\_\_

Model No. \_\_\_\_\_

Date of Installation \_\_\_\_\_

---

# Contents

---

Important Information . . . . .	4
9KOH Specifications . . . . .	6
Installation Requirements . . . . .	9
Installation Procedure . . . . .	11
Lift Lockout/Tagout Procedure . . . . .	20
Operating Instructions. . . . .	22
Safety Procedures. . . . .	24
Troubleshooting. . . . .	27
Illustrated Parts Breakdown . . . . .	29
Parts List . . . . .	32
Warranty . . . . .	35

---

# Important Information

---

1. Any freight damage must be noted on the freight bill before signing and reported to the freight carrier with a freight claim established. Identify the components and check for shortages. If shortages are discovered, please contact the Distributor / Sales Rep. in your area for service.
2. Consult building owner and / or architect's plans when applicable to establish the best lift location. The lift should be located on a relatively level floor with 4 in. minimum thickness, 3000-psi concrete slab that has been properly cured. **There can be no cracks in the slab within 36 in. of the base plate location, and no seams in the foundation within 6 in. of its location! Remember: any structure is only as strong as the foundation on which it is located!**

**IMPORTANT! Make sure you have extra help or heavy duty lifting equipment when unloading and assembling the lift.**

3. Please read the safety procedures and operating instructions in this manual before operating lift. Keep this manual near lift at all times. Make sure all operators read this manual.
4. The lift should be located on a relatively level floor of less than 3 degrees slope. If slope is questionable, consider a survey of the site and/or the possibility of pouring a new level concrete slab.
5. Make sure you have enough area and ceiling height to install lift. (See Lift Specifications)
6. Never raise a car until you have double checked all bolts, nuts and hose fittings.
7. Always lower the lift onto the locks before going under the vehicle.
8. Never allow anyone to go under the lift when raising or lowering.

**This is a vehicle lift installation/operation manual and no attempt is made or implied herein to instruct the user in lifting methods particular to an individual application. Rather, the contents of this**

manual are intended as a basis for operation and maintenance of the unit as it stands alone or as it is intended and anticipated to be used in conjunction with other equipment.

Proper application of the equipment described herein is limited to the parameters detailed in the specifications and the uses set forth in the descriptive passages. Any other proposed application of this equipment should be documented and submitted in writing to the factory for examination. The user assumes full responsibility for any equipment damage, personal injury, or alteration of the equipment described in this manual or any subsequent damages.

## **CAUTION!!**

**ENSURE THAT ALL CABLE SHEAVES, BEARINGS, AND SHAFTS ARE SUFFICIENTLY LUBRICATED. ALSO, THE CORNERS OF EACH COLUMN SHOULD BE LIGHTLY GREASED WITH QUALITY TYPE LITHIUM GREASE PRIOR TO OPERATING THE LIFT. LUBRICATE ALL ON AN ANNUAL BASIS.**

**Motors and all electrical components are not sealed against the weather and moisture. Install this lift in a protected indoor location. Failure by the owner to provide the recommended shelter could result in unsatisfactory lift performance, property damage, or personal injury.**

This lift is an 9,000 lb. capacity, 2-Post Lifts. The locking latch system is very similar to an extension ladder. The locking latch is in contact with the latch rack. As the lift rises the locking latch drops into place. The locking latch engages in latch rack in 3" increments starting at about 16" from the ground. The locking latches must be manually disengaged for the lift to lower. The locking latch is released by pulling the Release Cable raising the latch up off the latch rack. Once the raise button is pressed, the latch will automatically reengage after approximately 3" of travel. Heavy bearings and heavy-duty leaf chains are used throughout the lift. The work is done with the heavy-duty chain connected to a 2-1/2" cylinder, driven by an electric / hydraulic pump.

# 9KOH Specifications

---

Capacity	9,000 lbs. (2,250 lbs per Arm)
Rise Time	60 Seconds
Overall Height	142"
Overall Floor Width	134-1/4"
Maximum Lift Height	74" (with adapters 80-1/2)
Minimum Pad Height	4"
Between Columns	109-3/4"
Column Size	7-1/4" x 11-1/8"
Drive Thru	101.54"
Motor	2HP, 208 - 230 VAC, 1PH

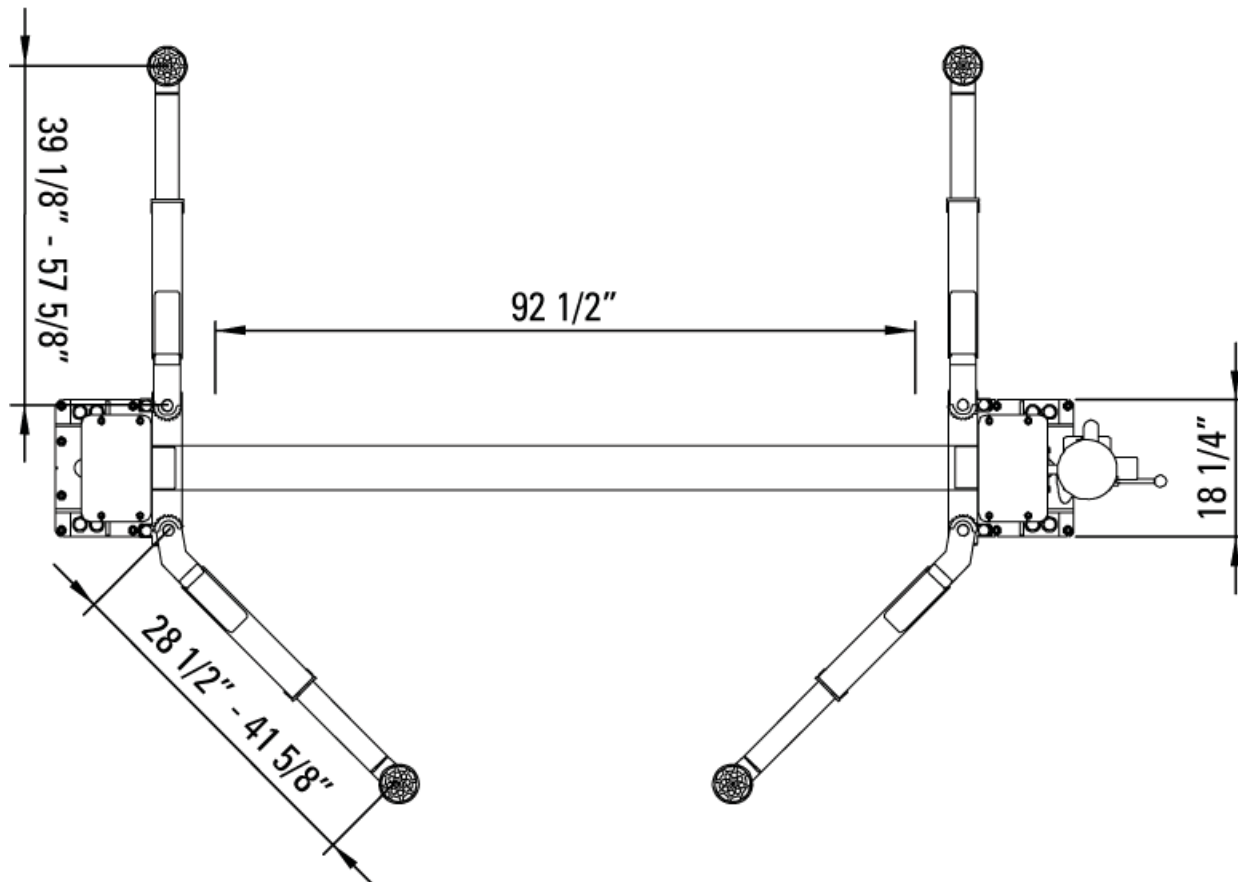

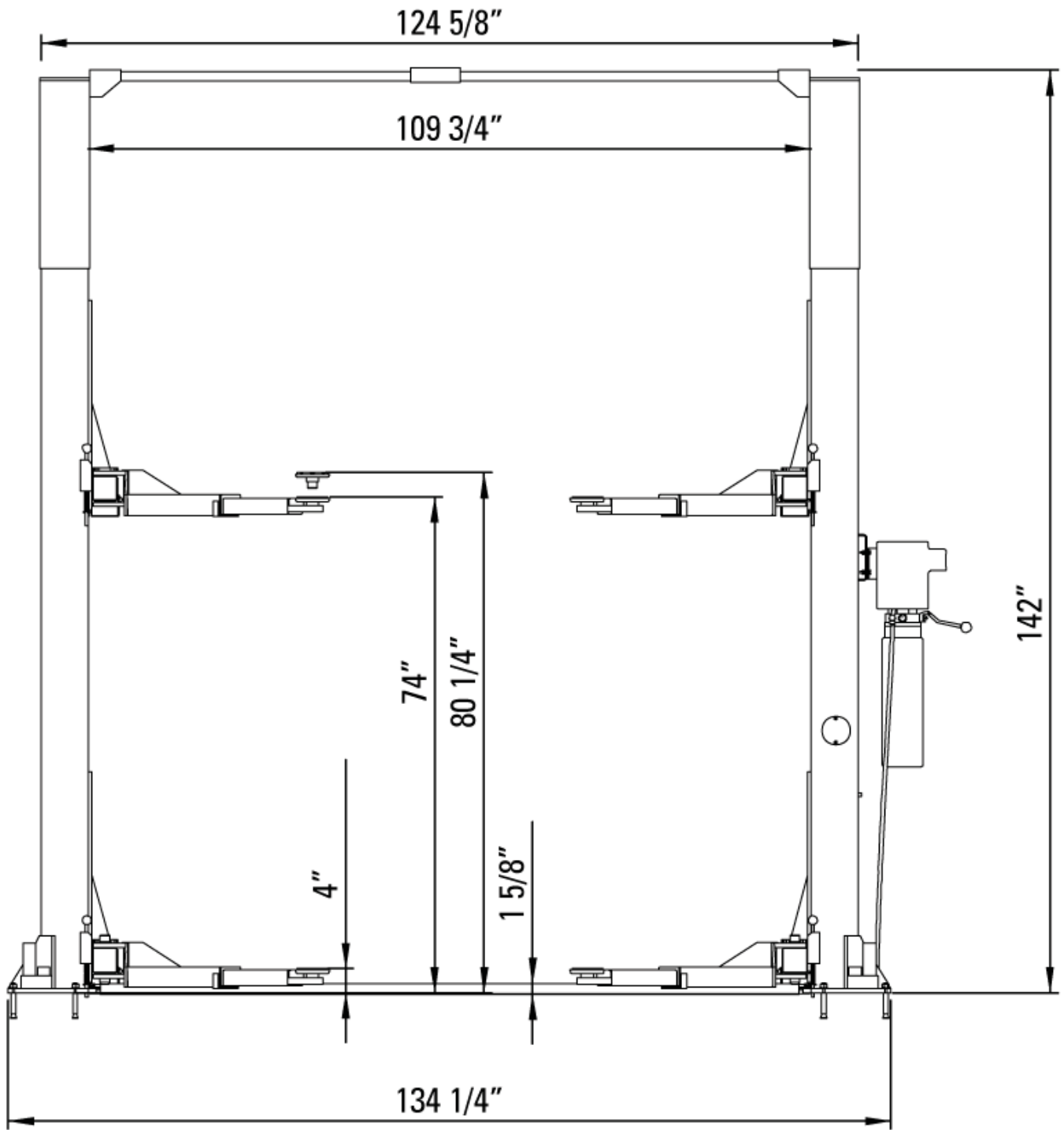

# Asymmetrical Arm configuration

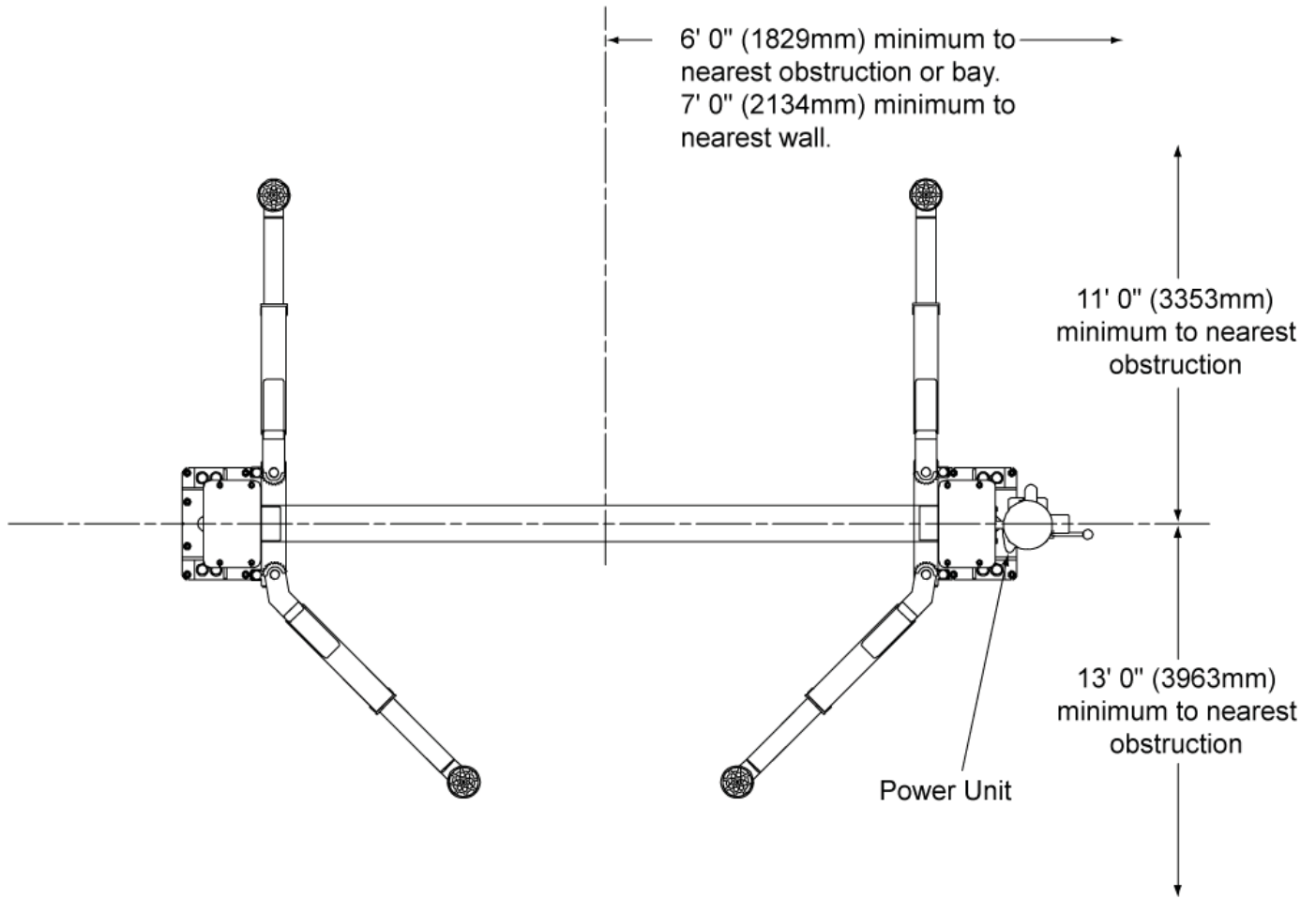

**NOTE:** Lift can be installed so power unit can column can be located on either side. However to save operation steps it is recommended that it is placed on passenger side of lift.



# Installation Requirements

---

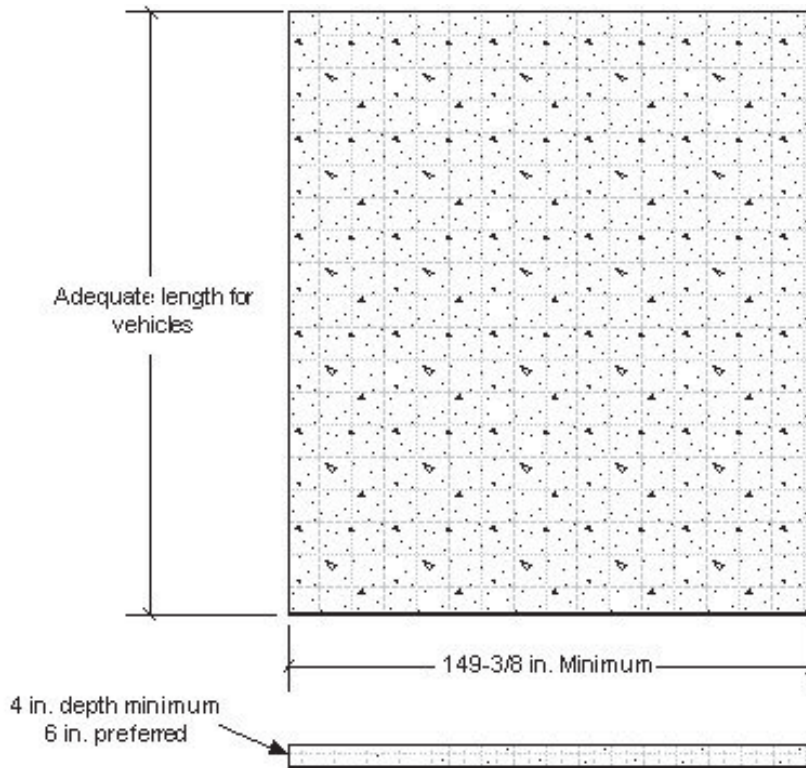

1. Concrete shall have compression strength of at least 3,000 PSI and a minimum thickness of 4" in order to achieve a minimum anchor embedment of 3 1/4". NOTE: When using the standard supplied 3/4" x 5 1/2" long anchors; if the top of the anchor exceeds 2 1/4" above the floor grade, you DO NOT have enough embedment.
2. Maintain a 6" minimum distance from any slab edge or seam. Hole to hole spacing should be a minimum 6 1/2" in any direction. Hole depth should be a minimum of 4".

## CAUTION!!

3. DO NOT install on asphalt or other similar unstable surface. Columns are supported only by anchoring to floor.
4. Using the horseshoe shims provided, shim each column base as required until each column is plumb. If one column has to be elevated to match the plane of the other column, full size base shim plates should be used. Torque

anchors to 110 ft-lbs. Shim thickness MUST NOT exceed 1/2" when using the 5 1/2" long anchors provided with the lift. Adjust the column extensions plumb.

5. If anchors do not tighten to 110 ft-lbs. installation torque, replace the concrete under each column base with a 4' x 4' x 6" thick 3,000 PSI minimum concrete pad keyed under and flush with the top of existing floor. Allow concrete to cure before installing lifts and anchors (typically 2 to 3 weeks).

## Tools Required

**The installation of this lift is relatively simple and can be accomplished by two men in a few hours.**

**The following tools and equipment are needed:**

- Hoist or Forklift (optional)
- Metric Sockets and Open Wrench set
- Two 10' to 12' step ladders
- Vise grips
- ISO 32 Light Hydraulic Oil (approx. 12 quarts)
- 8mm Socket Head Wrench
- Tape Measure
- Torque wrench with 1-1/8" socket for anchors
- 4' Level
- Teflon Tape
- Rotary Hammer Drill with 3/4 in. Drill Bit (Core Drill Rebar Cutter recommended)

# Installation Procedure

---

1. After unloading the lift, place it near the intended installation location.
2. Remove the shipping bands and packing material from the lift. The power unit and cylinders will be unpacked from the top.
3. Open the wrapping from the upper column and carefully remove the parts from inside. Unbolt the column from the shipping brackets. Unbolt the up-rights from the columns and assemble it to the column.
4. Remove the packing brackets and bolts holding the two columns together (do not discard bolts; they are used in the assembly of the lift).
5. Once the power unit column location is decided, insure that the proper lift placement is observed from walls and obstacles. Also check the ceiling height for clearance in this location. **NOTE: the power unit column can be located on either side. It is helpful to try and locate the power side with the passenger side of the vehicle when loaded on the lift to save steps during operation.**
6. Unpack the cylinders and open the oil port on each cylinder by unscrewing the black plastic cap. Move the carriage up about 20" to 25". Next, carefully slide the cylinder inside from the bottom of the carriage. The oil port will face the backside of the column and the notch on the bottom of the cylinder will fit into the hole in the center of the base plate.
7. Position the columns facing each other 107-1/4" inside base plates. Square the columns by measuring diagonally from the corner points on the base plates (within 1/4").

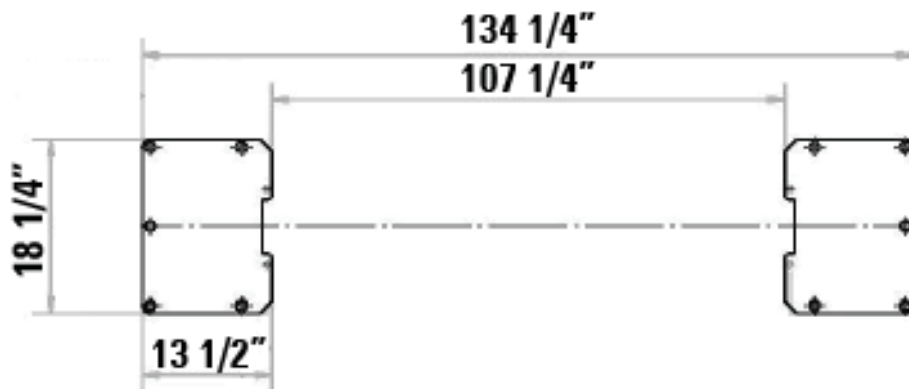

8. Use the existing holes in column base plate as a guide for drilling the 3/4" diameter holes into the concrete. Drill the anchor holes only for ONE column, installing anchors as you go. You will install anchors in second column after the cables, hoses, and cross beam are installed.

NOTE: Drilling thru concrete slab (recommended) will allow the anchor to be driven thru the bottom of slab, if the threads are damaged or if the lift will need to be relocated.

## **CAUTION!!**

### **Anchors must be at least 6" from the edge of the slab or any seam.**

- Use a concrete hammer drill with a carbide tip, solid drill bit the same diameter as the anchor, 3/4". (.775 to .787 inches diameter). Do not use excessively worn bits or bits which have been incorrectly sharpened.
- Keep the drill in a perpendicular line while drilling.
- Let the drill do the work. Do not apply excessive pressure. Lift the drill up and down occasionally to remove residue to reduce binding.
- Drill the hole to depth equal to the length of anchor. **Note:** Drilling thru concrete (recommended) will allow the anchor to be driven thru the bottom of foundation if the threads are damaged or if the lift will need to be relocated.
- For better holding power blow dust from the hole.

Place a flat washer and hex nut over threaded end of anchor, leaving approximately 1/2" of thread exposed carefully tap anchor. Do not damage threads. Tap anchor into the concrete until nut and flat washer are against base plate. Do not use an impact wrench to tighten! Tighten the nut, two or three turns on average concrete (28-day cure). If the concrete is very hard only one or two turns may be required. Check each anchor bolt with torque wrench set to 110 foot pounds.

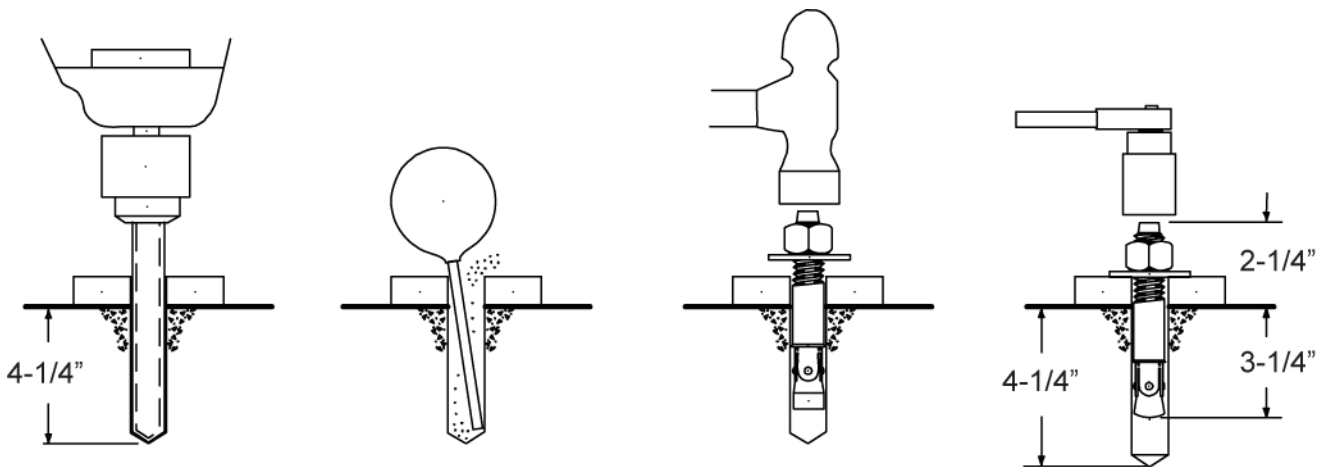

Drill holes using 3/4" carbide tipped masonry drill bit per ANSI standard B94.12.1977

Clean hole.

Run nut down just below impact section of bolt. Drive anchor into hole until nut and washer contact base.

Tighten nut with Torque wrench to 110 ft-lbs.

9. Using a level, check column for side-to-side plumb and front-to-back plumb. If needed, use horseshoe shims provided by placing shims underneath the base plate and around the anchor bolt. This will prevent bending the column bottom plates (Shim thickness should not exceed 1/2"). Tighten 3/4" anchor bolts to **110 ft-lbs.** of torque.
10. Using a tape measure, measure from corner of the base on main side column to the opposite corner of the offside column to insure legs are square (within a 1/4").
11. Set carriages on the first safety latch engagement. Be sure each carriage is at the same height by measuring from the top of the base to the bottom of the carriage (double check the latches before working under the carriages). This dimension should be within 1/4".
12. Installing the equalizing cables: for general cable arrangement. Route the first cable as shown on next page. Tighten nut on one cable stud so that the end of stud passes the nylon on the nut. Pull the other end of cable and run nut on it. Repeat above for second cable.

**NOTE: DO NOT tighten cables at this time. Just start them on the threads. Other column will be anchored in later steps. If you tighten cables at this time you will pull the column and be unable to properly level/shim it for anchor installation.**

13. Install the overhead cross beam. This cross beam has two pieces to be connected by five (5) bolts in the center of the beam. Be sure to bolt them together by installing the bolts from inside the cross beam out. This is to avoid interference with the cable when operating the lift. Next, install the cross beam between two columns.
14. After fastening the cross beam, check and confirm that the remaining column is plumb.
15. Secure the remaining column by duplicating STEP 6 and STEP 7.
16. Mount the power unit on the main side leg to the power unit bracket using the four 5/16" bolts and nuts. Connect the power unit to the fitting installed on the back of the main leg using a short hose supplied.

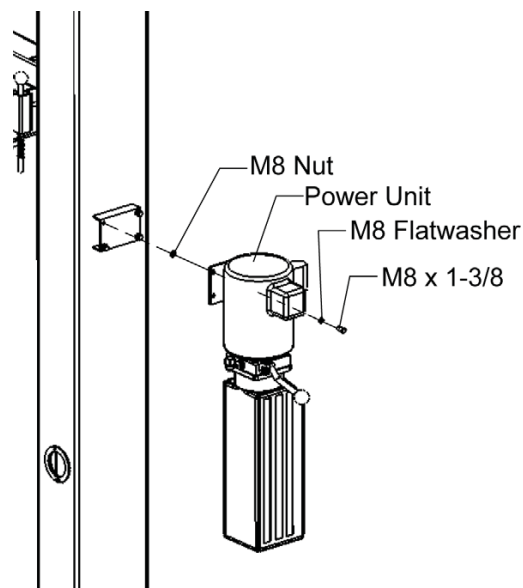

17. Connect the equalizing cables. Do not tighten as this stage of assembly.

**NOTE:** The cable stud that connects to the front right corner of the carriage should be connected first by pulling the stud through the carriage hole and up where it is easy to be held by locking pliers. Pull the stud back into place after threading at least 1/2" of the stud past the locknut. Connect the other ends to the rear right corners of the carriage with at least 1/2" of thread showing past the lock nut (cables run on the inside of the carriage). It may be necessary to manually raise both carriages above the cylinder to provide enough space to use the locking pliers. Make sure the carriage is set in the LOCK position.

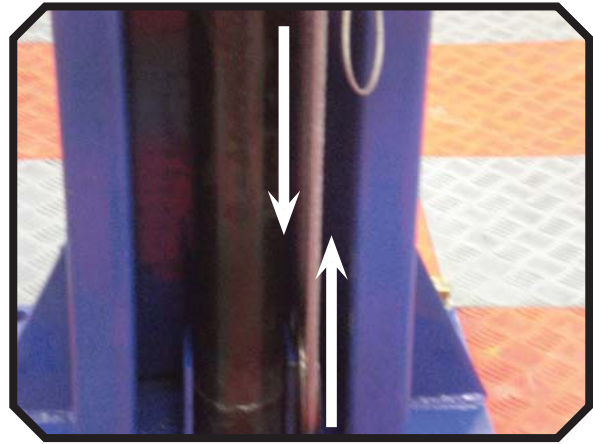
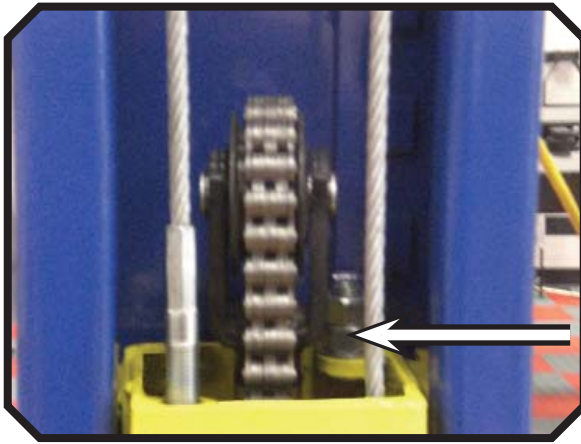

This is the Power (Motor) Side, carriage. The nuts you see to the right-rear are where the cables start. Both nuts go above the eyelet, one nut acts as a locking nut. The cable will pass down and around the pulley, rear to front, then travel back up and across to the other side.

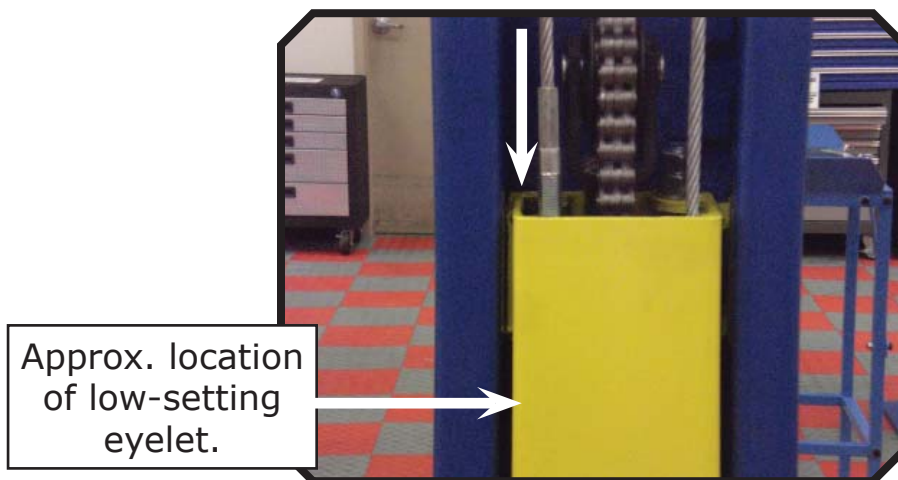

This is the Non-Powered side carriage. The arrow is where the cable from the Power side comes down. For the Highest setting, use the eyelet at the top, left hand corner. For the low setting, directly below the top eyelet, there is a second eyelet inside the carriage. Pass the cable through the top eyelet and bolt into the inner, hidden eyelet. Just be sure cables do not cross and do not tighten the cable nuts down until they are run around the pulleys.



18. Adjust the carriage cable tension. This is accomplished by tightening the carriage adjustment nut on the top of each carriage. The rear carriage adjustment nut adjusts the opposite post carriage height. The left post carriage nut adjusts the right column carriage, and the right column carriage nut adjusts the left column carriage. Adjust each cable to approximately 1/2" side-to-side play.
19. Cylinder centering and chain installation: Make sure the "Tip" on the bottom of the cylinder is properly located into the center hole on top of the cylinder mount in base. Pull the pre-attached leaf chain in both sides up and over the chain sheave on top of the cylinders.

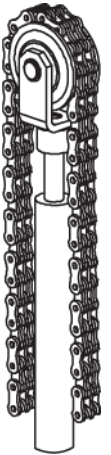

**Incorrect**



The Chain Break lock is activated and the carriage will not lower.

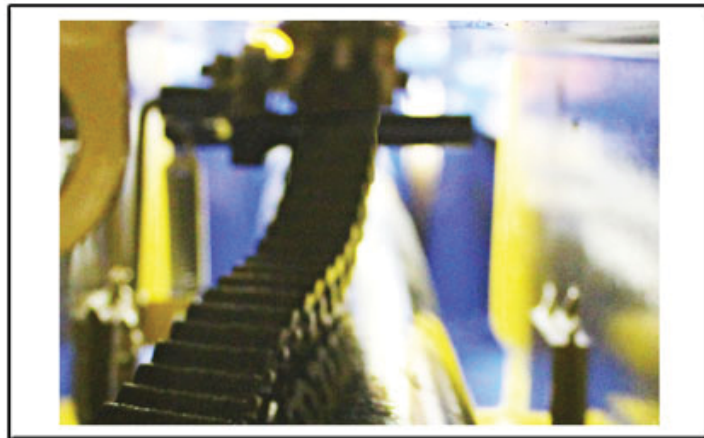

When installing the lift, the chain must be in front of the chain break to operate.

**Correct**

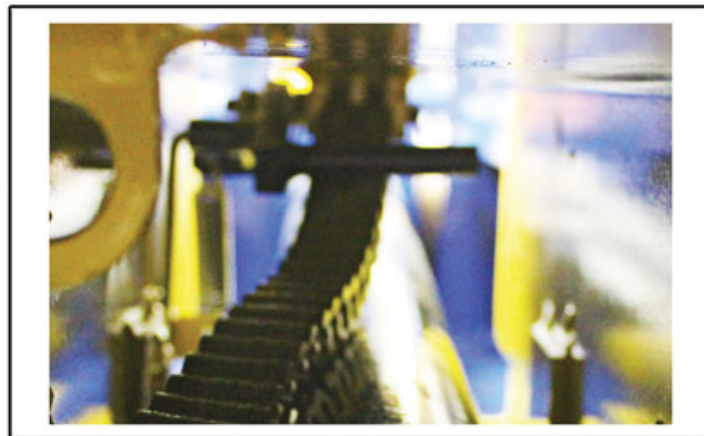

20. Connect the Hydraulic Hoses and Fittings.
21. Install remaining anchors at this point using directions from page 8.
22. Install the swing arms on the carriages using the included 1-1/2" diameter pins. Check for proper engagement of the arm lock – the rack on the lock should fully engage the gear on the arm. Note you may have to loosen the arm lock bolts to get proper engagement and to install the arm pins. BE SURE to retighten the lock bolts after the arm pins are installed.



23. Adjust the carriage cables tension. Adjust each cable to approximately 1/2" side-topside play. Check the latch releases to insure the carriage is still sitting on the appropriate latch.
24. Remove the vent plug from the power unit and fill the reservoir. Use a Ten Weight (ISO AW32) non-foaming, non-detergent hydraulic fluid (i.e. Texaco HD32 or equal). The unit will hold approximately twelve quarts of fluid.
25. Install both the "Overhead Shut-Off Bar" and "Limit Switch" on to the overhead cross beam.

## Wiring The Overhead Shut Off Bar Limit Switch

This is the way the hydraulic power unit is wired from the factory. Wire colors may vary. The pre wired "Pig Tail" is on there as a reference point so the electrical contractor knows which terminal to use. **DO NOT** splice into the "Pig Tail" with extension wire to the breaker box. Remove and discard the "Pig Tail" wires. It is recommended that a 220 Volt, 30 Amp twist lock plug be installed in the power line just ahead of the power unit. Use wire capable of supporting a 30-amp circuit.

**Warning: the wiring must comply with local code. Have a certified electrician make the electrical hook-up to the power unit. Protect each circuit with time delay fuse or circuit breaker; 208v-230v single phase 60 Hz 30 amp.**



# Remove Existing Pigtail From Lift (Do Not Operate Until Completed)

## 1.) Incoming Power (Factory Installed)

- One hot to **terminal 6**
- One hot to **terminal 2**
- Ground to ground

## 2.) Motor (Factory Installed)

- One hot to **terminal 8**
- One hot to **terminal 4**

## 3.) Limit Switch

- Cut ground off,  
**DON'T USE!**
- One hot to **Up Button terminal 4**
- One hot to **terminal 1**

## 4.) Jumpers (Factory Installed)

- Jumper from **Up Button terminal 3** to **terminal 6**
- Jumper from **terminal 2** to **terminal 0**

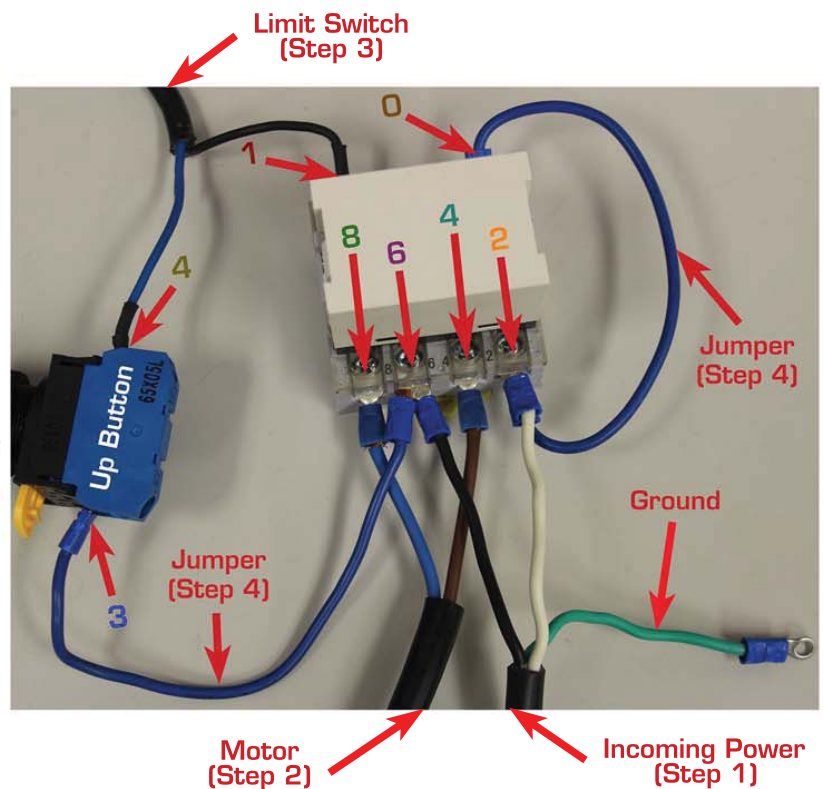
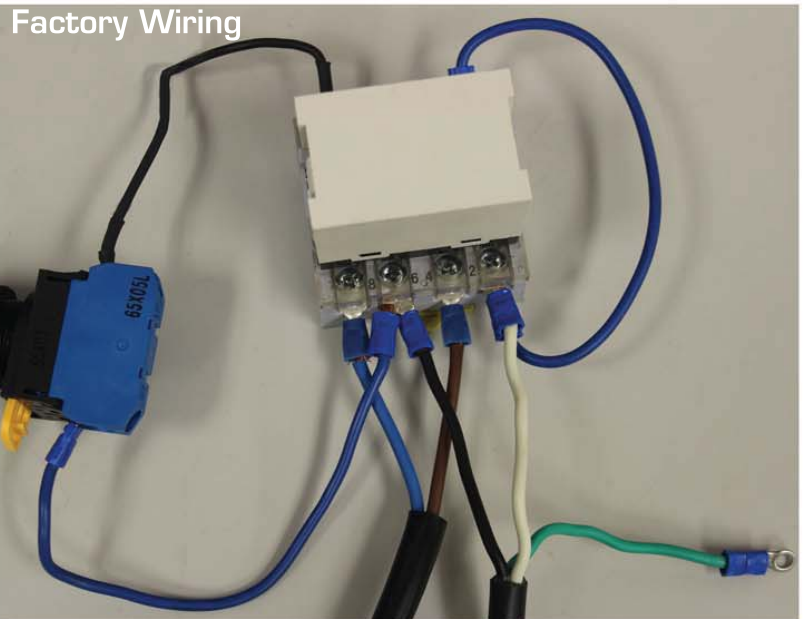

# Lift Lockout/Tagout Procedure

---

## Purpose

This procedure establishes the minimum requirements for the lockout of energy that could cause injury to personnel by the operation of lifts in need of repair or being serviced. All employees shall comply with this procedure.

## Responsibility

The responsibility for assuring that this procedure is followed is binding upon all employees and service personnel from outside service companies (i.e., Authorized Installers, contactors, etc.). All employees shall be instructed in the safety significance of the lockout procedure by the facility owner/manager. Each new or transferred employee along with visiting outside service personnel shall be instructed by the owner/manager (or assigned designee) in the purpose and use of the lockout procedure.

## Preparation

Employees authorized to perform lockout shall ensure that the appropriate energy isolating device (i.e., circuit breaker, fuse, disconnect, etc.) is identified for the lift being locked out. Other such devices for other equipment may be located in close proximity of the appropriate energy isolating device. If the identity of the device is in question, see the shop supervisor for resolution. Assure that proper authorization is received prior to performing the lockout procedure.

## Sequence of Lockout Procedure

1. Notify all affected employees that a lockout is being performed and the reason for it.
2. Unload the subject lift. Shut it down and assure the disconnect switch is "OFF" if one is provided on the lift.

3. The authorized lockout person operates the main energy isolation device removing power to the subject lift.
  - a. If this is a lockable device, the authorized lockout person places the assigned padlock on the device to prevent its unintentional reactivation. An appropriate tag is applied stating the person's name, at least 3" x 6" in size, an easily noticeable color, and states not to operate device or remove tag.
  - b. If this device is a non-lockable circuit breaker or fuse, replace with a "dummy" device and tag it appropriately as mentioned above.
4. Attempt to operate lift to assure the lockout is working. Be sure to return any switches to the "OFF" position.
5. The equipment is now locked out and ready for the required maintenance or service.

## **Restoring Equipment to Service**

1. Assure the work on the lift is complete and the area is clear of tools, vehicles, and personnel.
2. At this point, the authorized person can remove the lock (or dummy circuit breaker or fuse) and tag and activate the energy isolating device so that the lift may again be placed into operation.

## **Rules for Using Lockout Procedure**

Use the Lockout Procedure whenever the lift is being repaired or serviced, waiting for repair when current operation could cause possible injury to personnel, or for any other situation when unintentional operation could injure personnel. No attempt shall be made to operate the lift when the energy isolating device is locked out.

## **Operating Conditions**

Lift is not intended for outdoor use and has an operating ambient temperature range of 41°-104°F (5°-40°C).

# Operating Instructions

---

**Only authorized personnel are to operate lift**

**Read operating and safety procedures manual completely before operating lift.**

- Properly maintain and inspect lift in accordance to owner's manual.
- Do not operate a lift that is damaged or in need of repair.
- Allow only authorized personnel in the lift bay.
- Stay clear of Lift when raising or lowering (NO RIDERS)
- Keep hands and feet away from pinch points at all times.
- Never override the Lifts operating and safety controls.
- If a vehicle is suspected of falling, clear area immediately.
- Do not rock vehicle while positioned on lift.
- Always use safety jack stands when removing or installing heavy components.

## **Vehicle Loading**

- Position vehicle for proper weight distribution (center of gravity should be midway between adapters).
- Swing arms under vehicle to allow adapters to contact at the manufacturer's recommended pick up points.
- Use caution before lifting pickup trucks, suv's and other framed vehicles. The individual axle weight capacity should not exceed 1/2 of lift capacity.
- Make sure vehicle is neither front nor rear heavy.
- Make sure the lifting pads are in a proper and safe position to support the vehicle. (Ref: Lifting Points Guide and decal on Main side column for typical arm positioning)



## Raising Lift

- Push Up switch to raise lift (make sure arm restraints engage or stop and slightly move arm to allow gear to mesh) until tires clear floor.
- Stop and check for secure contact on adapters and vehicle weight distribution. If secure raise to desired height.
- ALWAYS lower the lift into the nearest lock position by pressing the lower lever to relieve the hydraulic pressure and let the latch set right in a lock position.
- Never work under a lift that is not in the locked position.

## Lowering Lift

- Clear all obstacles from under lift and vehicle and ensure only the lift operator is in the lift area.
- Stay clear of lift and raise the lift off the safety locks.
- Pull safety latch releases and press the lower lever to begin descent.
- Unload lift by first completely lowering lift, then swinging arms to drive-thru position before moving vehicle.

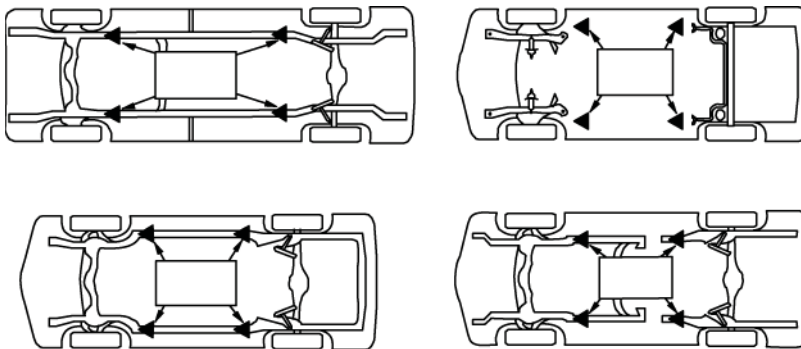

## Lift Points Note:

Refer to the manufacturer's specific vehicle lifting points. Some vehicles display these points on a label inside the right front door lock face or are identified by triangle shape marks on the vehicle's undercarriage, reference SAE J2184.

# Safety Procedures

---

- Never allow unauthorized persons to operate lift. Thoroughly train new employees in the use and care of lift.
- Caution - the power unit operates at high pressure.
- Remove passengers before raising vehicle.
- Prohibit unauthorized persons from being in shop area while lift is in use.
- Total lift capacity is 9,000 lbs. @ 2,250 lbs per lifting pad. Do not exceed maximum weight capacity of lift.
- Prior to lifting vehicle, walk around the lift and check for any objects that might interfere with the operation of lift and safety latches; tools, air hoses, shop equipment.
- When approaching the lift with a vehicle, make sure to center the vehicle between the columns so that the tires will clear the swing arms easily. Slowly drive the vehicle between the columns. It is recommended to have someone outside the vehicle guide the driver.
- Always lift vehicle using all four pads.
- Never use lift to raise one end or side of vehicle.
- Always raise vehicle about 3" and check stability by rocking vehicle.
- Prior to lowering vehicle, walk around the lift and check for any objects that might interfere with the operation of lift and safety latches; tools, air hoses, shop equipment.
- Always lower lift to the lock position before going under vehicle. Never allow anyone to go under the lift when raising or lowering.

## Preventive Maintenance Schedule

The periodic Preventive Maintenance Schedule given is the suggested minimum requirements and minimum intervals; accumulated hours or monthly period, which ever comes sooner. Periodic maintenance is to be performed on a daily, weekly, and yearly basis as given in the following paragraphs.



# WARNING!!

- Occupational Safety and Health Administration (OSHA) and the American National Standards Institute (ANSI) requires users to inspect lifting equipment at the start of every shift. These and other periodic inspections are the responsibility of the user.
- Failure to perform the daily pre-operational check can result in expensive property damage, lost production time, serious personal injury, and even death. The safety latch system must be checked and working properly before the lift is put to use.
- Failure to heed this warning can result in death or serious injury, or damage to equipment. If you hear a noise not associated with normal lift operation, or, if there is any indications of impending lift failure - **CEASE OPERATION IMMEDIATELY!** - Inspect, correct and/or replace parts as required.

## Daily Pre-Operation Check (8-Hours)

1. Check safety lock audibly and visually while in operation
2. Check safety latches for free movement and full engagement with rack.
3. Check hydraulic connections, and hoses for leakage.
4. Check chain connections - bends, cracks-and loose links.
5. Check cable connections- bends, cracks-and looseness.
6. Check for frayed cables in both raised and lowered position.
7. Check snap rings at all rollers and sheaves.
8. Check bolts, nuts, and screws and tighten if needed.
9. Check wiring & switches for damage.
10. Keep base plate free of dirt, grease or any other corrosive substances.
11. Check floor for stress cracks near anchor bolts.
12. Check swing arm restraints.

## Weekly Maintenance (every 40-Hours)

1. Check anchor bolts torque to 110 ft-lbs for the  $\frac{3}{4}$  in. anchor bolts. Do not use an impact wrench to tighten anchor bolts.
2. Check floor for stress cracks near anchor bolts.
3. Check hydraulic oil level.
4. Check and tighten bolts, nuts, and screws.

5. Check cylinder pulley assembly for free movement or excessive wear on cylinder yoke or pulley pin.
6. Check cable pulley for free movement and excessive wear.

### **Yearly Maintenance**

1. Lubricate chains
2. Grease rub blocks and column surface contacting rub blocks
3. Change the hydraulic fluid - good maintenance procedure makes it mandatory to keep hydraulic fluid clean. No hard fast rules can be established; - operating temperature, type of service, contamination levels, filtration, and chemical composition of fluid should be considered. If operating in dusty environment shorter interval may be required.

### **Special Maintenance Tasks**

**NOTE:** The following items should only be performed by a trained maintenance expert:

- Replacement of hydraulic hoses.
- Replacement of chains and rollers.
- Replacement of cables and sheaves.
- Replacement or rebuilding air and hydraulic cylinders as required.
- Replacement or rebuilding pumps / motors as required.
- Checking of hydraulic cylinder rod and rod end (threads) for deformation or damage.

## **CAUTION!!**

**Relocating or changing components may cause problems. Each component in the system must be compatible; an undersized or restricted line will cause a drop in pressure. All valve, pump, and hose connections should be sealed and/or capped until just prior to use. Air hoses can be used to clean fittings and other components. However, the air supply must be filtered and dry to prevent contamination. Most important is cleanliness; Contamination is the most frequent cause of malfunction or failure of hydraulic equipment.**

# Troubleshooting

---

The common problems that may be encountered and their probable causes are covered in the following paragraphs:

PROBLEM	SOLUTION
Motor Does Not Operate	<p><b>Failure of the motor to operate is normally caused by one of the following:</b></p> <ol style="list-style-type: none"> <li>1. Breaker or fuse blown.</li> <li>2. Faulty wiring connections; call electrician.</li> <li>3. Defective up button; call electrician for service.</li> </ol>
Motor Functions but Lift Will Not Rise	<p><b>If the motor is functioning, but the lift will not rise do the following in the order given:</b></p> <ol style="list-style-type: none"> <li>1. A piece of trash is under check valve. Push handle down and push the up button at the same time. Hold for 10-15 seconds. This should flush the system.</li> <li>2. Check the clearance between the plunger valve of the lowering handle. There should be 1/16" clearance.</li> <li>3. Remove the check valve cover and clean ball and seat.</li> </ol> <p style="text-align: center;"><b>WARNING!!</b></p> <p>Failure to properly relieve pressure in the following step can cause injury to personnel. This lift uses ISO Grade 32 or other good grade non-detergent hydraulic oil at a high hydraulic pressure. Be familiar with its toxicological properties, precautionary measures to take, and first aid measures as stated in the Safety Summary before performing any maintenance with the hydraulic system.</p> <ol style="list-style-type: none"> <li>4. Oil level too low. Oil level should be just under the vent cap port when the lift is down. Relieve all hydraulic pressure and add oil as required.</li> </ol>
Oil Blows out Breather of Power Unit	<p><b>If oil blows out of the breather of the power unit, take the following actions:</b></p> <ol style="list-style-type: none"> <li>1. Oil reservoir overfilled. Relieve all pressure and siphon out hydraulic fluid until at a proper level</li> <li>2. Lift lowered too quickly while under a heavy load. Lower the lift slowly under heavy loads.</li> </ol>

<p>Motor Hums and Will Not Run</p>	<p><b>If the motor hums but fails to run, take the following actions:</b></p> <ol style="list-style-type: none"> <li>1. Lift overloaded. Remove excessive weight from lift</li> </ol> <p style="text-align: center;"><b>WARNING!!</b></p> <p>The voltages used in the lift can cause death or injury to personnel. In the following steps, make sure that a qualified electrician is used to perform maintenance</p> <ol style="list-style-type: none"> <li>2. Faulty wiring Call electrician</li> <li>3. Bad capacitor Call electrician</li> <li>4. Low voltage Call electrician</li> </ol>
<p>Lift Jerks Going Up and Down</p>	<ol style="list-style-type: none"> <li>1. If the lift jerks while going up and down, it is usually a sign of air in the hydraulic system. Raise lift all the way to top and return to floor. Repeat 4-6 times. Do not let this overheat power unit.</li> </ol>
<p>Oil Leaks</p>	<p><b>Oil leak causes at the power unit and cylinders are normally caused by the following:</b></p> <ol style="list-style-type: none"> <li>1. Power unit: if the power unit leaks hydraulic oil around the tank-mounting flange check the oil level in the tank. The level should be two inches below the flange of the tank. A screwdriver can be used as a "dipstick".</li> <li>2. Cylinder - Piston Rod: the rod seal of the cylinder is out. Rebuild or replace the cylinder.</li> <li>3. Cylinder - Vent: the piston seal of the cylinder is out. Rebuild or replace the cylinder.</li> </ol>
<p>Lift makes excessive noise / vibrates</p>	<p><b>Excessive noise from the lift is normally caused by the following:</b></p> <ol style="list-style-type: none"> <li>1. Cross beam ends are rubbing the columns. Readjustment needed.</li> <li>2. Cylinder too tight, load lift half capacity and cycle up and down a few times to break in. Lift cylinder should quiet down with use. If not contact your Direct Lift Distributor to purchase an Oil Additive.</li> <li>3. May have excessive wear on cable sheaves or shafts. Replace them.</li> </ol>

# Illustrated Parts Breakdown

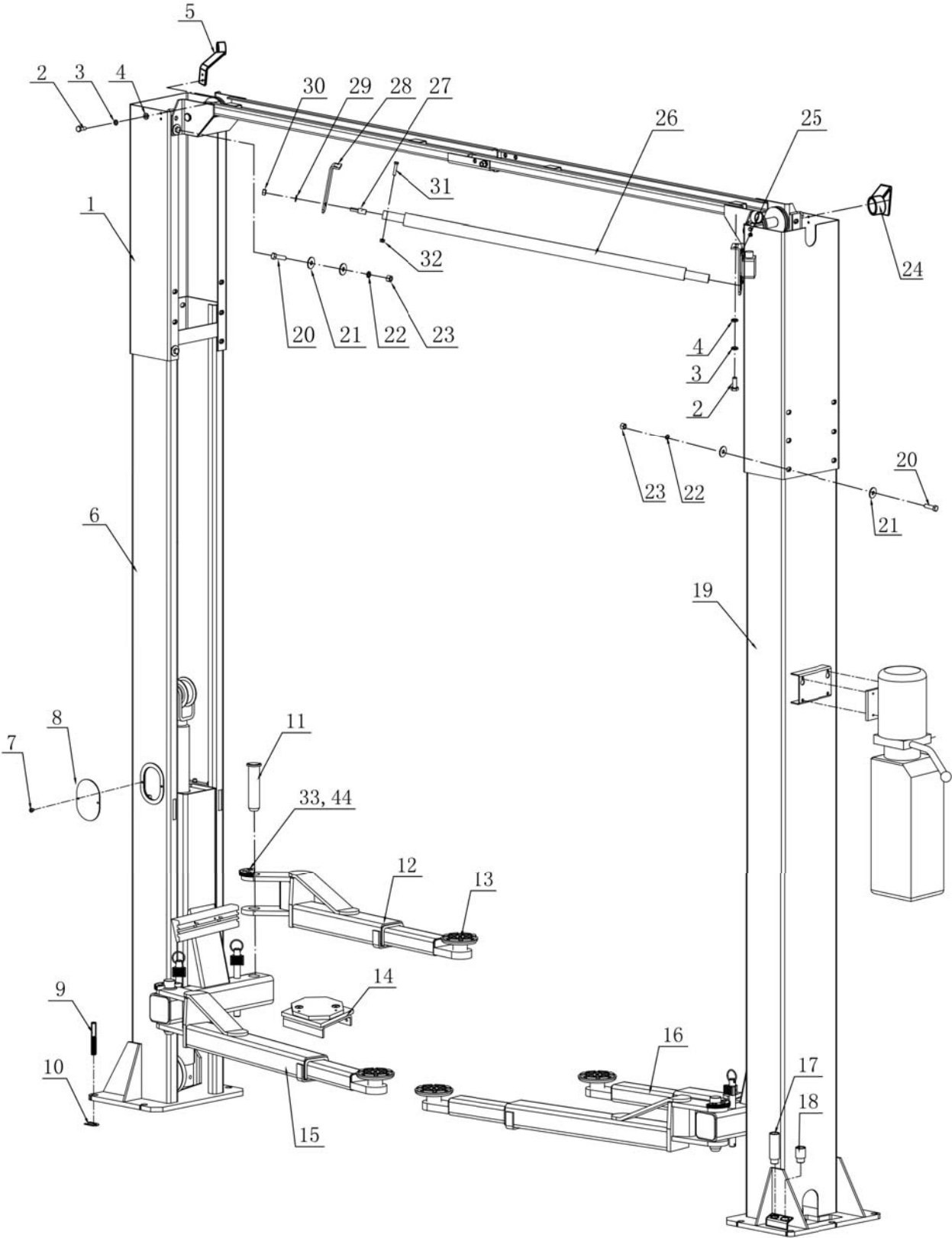

# Carriage Assembly

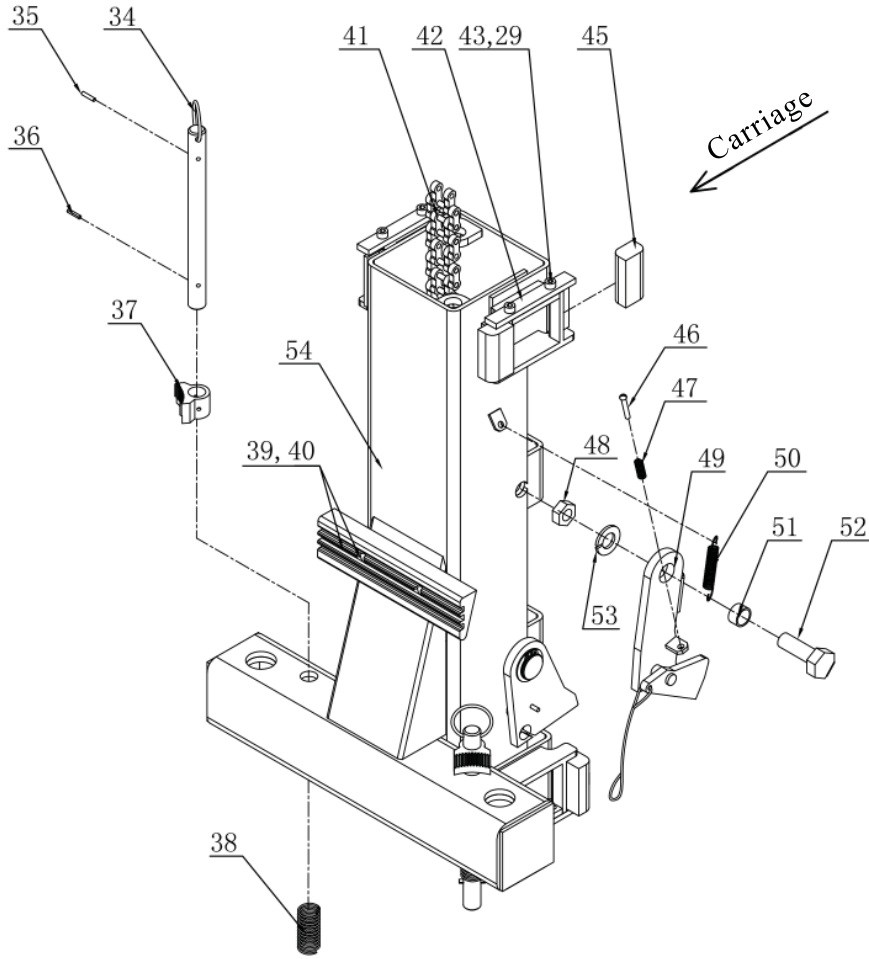

Carriage Reverse Side

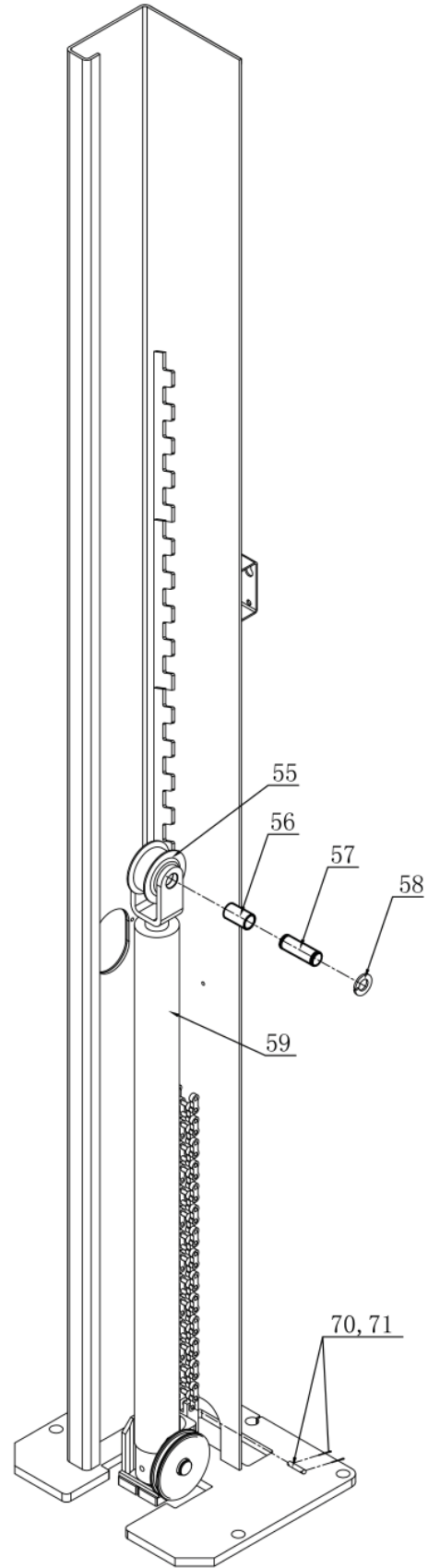
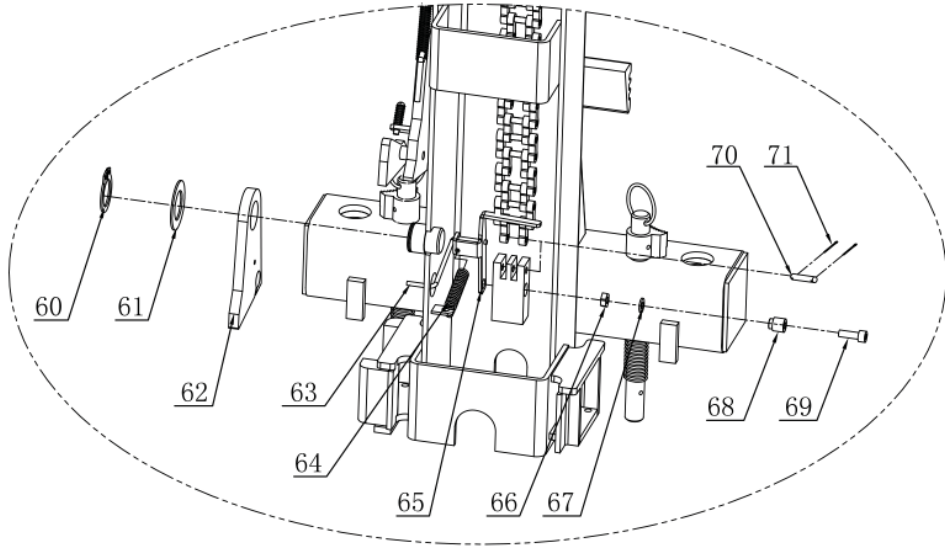

# Crossbeam

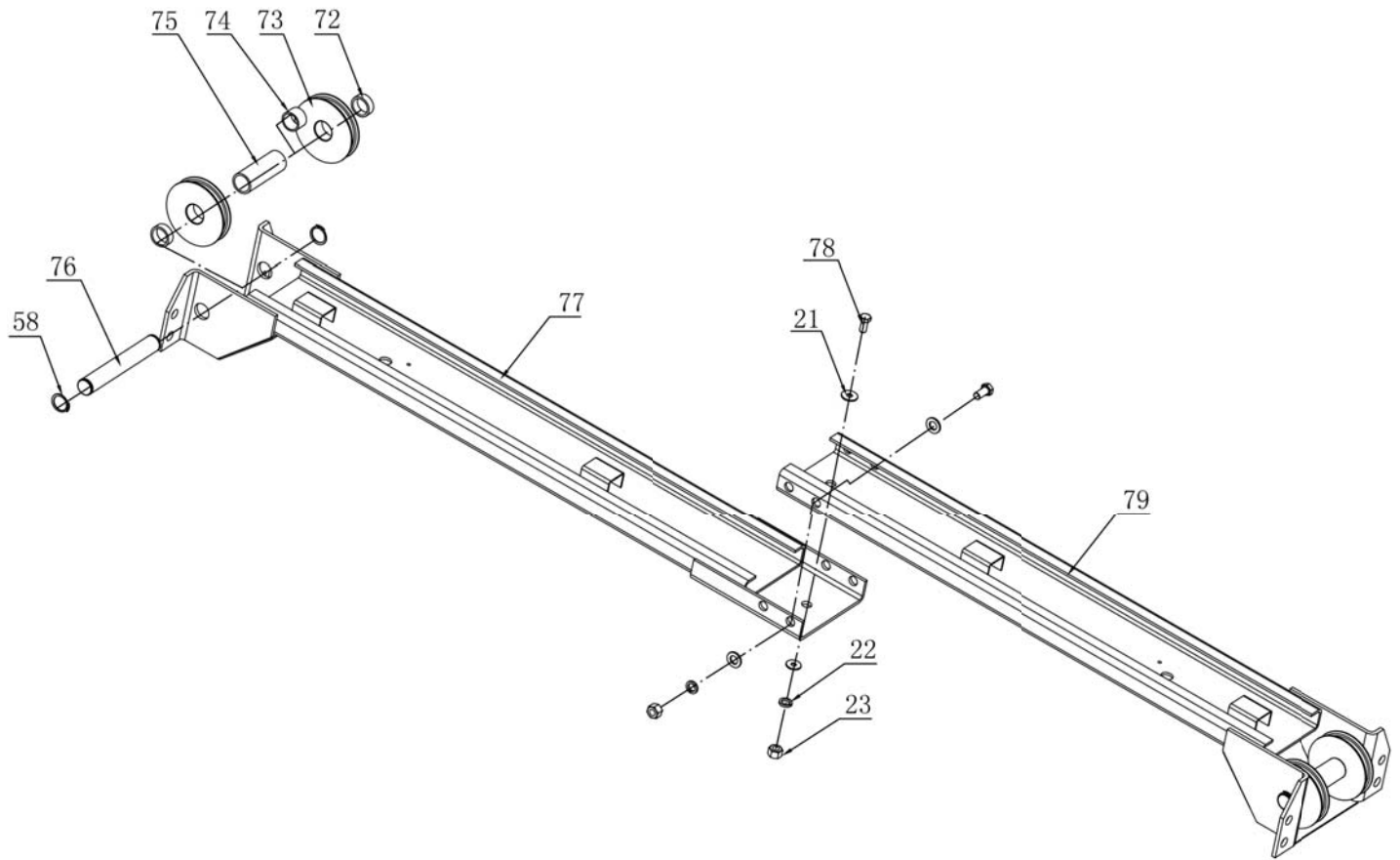

# Parts List

---

ITEM	DRAWING	DESCRIPTION	QTY
1	OH-3000	Extended column	2
2	GB70-85-M6*16	Cross recessed pan head screw	12
3	GB97.1-85-φ6	Spring washer φ6	12
4	GB93-87-φ6	Flat washer φ6	12
5	OH-3100	Tubing rack, left side	1
6	LSOH-1000B	Driven column welded group	1
7	GB818-85-M6*8	Cross recessed pan head screw	4
8	LSOH-1001	Window cover	2
9	PZ-3/4"*5.5"	Anchor bolt	10
10	30400-1025	"U" type plastic adjustment gasket	10
11	NTPF-5005	Arm pin	4
12	LSOH-7000	Bent arm weidment, left side	1
13	30400-6005-1G	Pallet with rubber pad	4
14	OH-6200	Sliding pad	2
15	LSOH-6000	Straight arm of welding group	2
16	LSOH-7000DC	Bent arm weidment, right side	1
17	30400-6015AG	Long adapter	4
18	30400-6014AG	Short adapter	4
19	LSOH-1000A	Active column welded group	1
20	GB5782-86-M12*40	Hexagonal bolt	12
21	GB93-87-φ12	Spring washer φ12	12
22	GB97.1-85-φ12	Flat washer φ12	24
23	GB6172-86-M12	Hexagon nut M12	12
24	OH-3200	Tubing rack, right side	1
25	OH-4400	Switch rack	1
26	HPRO-5003	Limited rod	1



ITEM	DRAWING	DESCRIPTION	QTY
27	HPRO-5004G	Connecting rod	2
28	HPRO-5001	Mounting rack of top rod	1
29	GB97.1-85-φ8	Spring washer φ8	17
30	GB6170-86-M8	Hexagon nut M8	1
31	GB5781-M6*30	Hexagonal bolt M6*30	1
32	HB8029-M6	Lock nut M6	1
33	52042C	Semicircle gear	4
34	9DA-2200	Arm lock pin	4
35	GB119-86-φ5*35	Elastic cylindrical pin	4
36	GB91-φ5*40	Cotter	4
37	30400-5014C	Small gear	4
38	NTPF-5012	Extension spring	4
39	OH-5500	Rubber door protection	2
40	GB70-85-M6*20	Cross recessed pan head screw	4
41	BL644*121P	Chain	2
42	30400-5003-1-2	Fixed plate of sliding block	8
43	GB5782-86-M8*20	Hexadon socket cap screw	16
44	GB5782-86-M10*16	Hexadon socket cap screw	12
45	30400-5024	Nylon Sliding block	16
46	GB818-M6*35	Cross recessed pan head screw	2
47	30400-5006-1	Spring	2
48	GB6170-86-M20	Hexagonal nut M20	2
49	30400-5006	Safety lock	2
50	30400-5006-3	Spring	2
51	30400-5011G	Bush of Safety lock	2
52	GB5783-86-M20*50	Hexagonal bolt	2
53	GB97.1-86-φ20	Spring washer φ20	2
54	LSOH-5000	Carriage	2
55	91773	Contact roller	2
56	91773-2	Bush of contact roller	2

ITEM	DRAWING	DESCRIPTION	QTY
57	30400-9012-01	Roller axle	2
58	GB894-1-86-φ25	Check ring φ25	8
59	N01-9100	Cylinder	2
60	GB894.1-86-φ35	Check ring φ35	2
61	GB97.1-85-φ36	Flat washer φ36	2
62	30400-5028	Chain lock	2
63	30400-5027	Connecting rod	2
64	30400-5032	Spring	2
65	30400-5029G	Chain lock	2
66	HB8029-M8	Lock nut M8	2
67	GB93-87-φ8	Flat washer φ8	2
68	30400-5035	Stop collar	2
69	GB5782-86-M8*60	Hexagon socket cap screw	2
70	30400-5023	Chain pin	2
71	GB91-φ2*20	Cotter	4
72	OH-4102	Short spacer	4
73	OH-4104	4 inch pulley	4
74	52004A	Thick cable wheel bushing	4
75	OH-4103	Long spacer	2
76	9DA-4101	Pulley shaft	2
77	9DA-4110	Crossbeam A	1
78	GB5782-86-M12*25	Hexagonal head bolt	5
79	9DA-4210	Crossbeam B	1

# Warranty

---



**This item** is warranted for one (1) years on structural components and one (1) year on air or electric hydraulic power units, pneumatic power units, cylinders and major components from date of invoice. Wear items are covered by a 90 day warranty.

This LIMITED warranty policy does **not include a labor** warranty.

**NOTE: ALL WARRANTY CLAIMS MUST BE PRE-APPROVED BY THE MANUFACTURER TO BE VALID.**

The Manufacturer shall repair or replace at their option for this period those parts returned to the factory freight prepaid, which prove after inspection to be defective. This warranty will not apply unless the product is installed, used and maintained in accordance with the Manufacturers installation, operation and maintenance instructions.

This warranty applies to the ORIGINAL purchaser only, and is non-transferable. The warranty covers the products to be free of defects in material and workmanship but, does not cover normal maintenance or adjustments, damage or malfunction caused by: improper handling, installation, abuse, misuse, negligence, carelessness of operation or normal wear and tear. In addition, this warranty does not cover equipment when repairs or alterations have been made or attempted to the Manufacturer's products.

THIS WARRANTY IS EXCLUSIVE AND IS LIEU OF ALL OTHER WARRANTIES EXPRESSED OR IMPLIED INCLUDING ANY IMPLIED WARRANTY OR MERCHANTABILITY OR ANY IMPLIED WARRANTY OF FITNESS FROM A PARTICULAR PURPOSE, AND ALL SUCH IMPLIED WARRANTIES ARE EXPRESSLY EXCLUDED.

THE REMEDIES DESCRIBED ARE EXCLUSIVE AND IN NO EVENT SHALL THE MANUFACTURER, NOR ANY SALES AGENT OR OTHER COMPANY AFFILIATED WITH IT OR THEM, BE LIABLE FOR SPECIAL CONSEQUENTIAL OR INCIDENTAL DAMAGES FOR THE BREACH OF OR DELAY IN PERFORMANCE OF THIS WARRANTY. THIS INCLUDES, BUT IS NOT LIMITED TO, LOSS OF PROFIT, RENTAL OR SUBSTITUTE EQUIPMENT OR OTHER COMMERCIAL LOSS.

**PRICES:** Prices and specifications are subject to change without notice. All orders will be invoiced at prices prevailing at time of shipment. Prices do not include any local, state or federal taxes.

**RETURNS:** Products may not be returned without prior written approval from the Manufacturer.