

INSTALLATION & OPERATION MANUAL



Atlas 412A 12,000 lb. Capacity 4 Post Alignment Lift



Atlas Automotive Equipment
www.atlasautoequipment.com
(866) 898-2604

Revised 2/04/2020

Read this entire manual before operation begins.

Record below the following information which is located on the serial number data plate.

Serial No. _____

Model No. _____





Date of Installation _____

———— Contents ————

General Information.	5
Product Identification	8
Packing / Transport / Storage	9
Lift Description	11
Technical Specification.	12
Safety	18
Installation	22
Operation And Use	33
Maintenance	36
Troubleshooting.	38
Parts List	39
Warranty	50

Printing Characters And Symbols

Throughout this manual, the following symbols and printing characters are used to facilitate reading:

	Indicates the operations which need proper care
	Indicates prohibited
	Indicates a possibility of danger to the operators
	Indicates the direction of access for motor vehicles to the lift
BOLD TYPE	Important information

	WARNING: before operating the lift and carrying out any adjustments, read carefully chapter 7 "Installation" where all operations for a properly functioning lift are shown.
---	---

General Information

This chapter contains warning instructions to operate the lift properly and prevent injury to operators or objects. This manual has been written to be used by shop technicians in charge of the lift (operator) and routine maintenance technician (maintenance operator). The operating instructions are considered to be an integral part of the machine and must remain with it for its whole useful life. Read every section of this manual carefully before operating the lift and unpacking. It provides helpful information about:

- **Safety Of People**
- **Safety Of The Lift**
- **Safety Of Lifted Vehicles**

The company is not liable for possible problems, damage, accidents, installation, etc. resulting from failure to follow the instructions contained in this manual. Only skilled technicians of AUTHORIZED DEALERS or SERVICE CENTERS AUTHORIZED by the manufacturer shall be allowed to carry out lifting, transport, assembling, installation, adjustment, calibration, settings, extraordinary maintenance, repairs, overhauling and dismantling of the lift.

The manufacturer is not responsible for possible damage to people, vehicles or objects if said operations are carried out by unauthorized personnel or the lift is improperly used.

Any use of the lift by operators who are not familiar with the instructions and procedures contained herein is unauthorized.

1.1 Manual Keeping

For a proper use of this manual, the following is recommended:

- Keep the manual near the lift, in an easily accessible place.
- Keep the manual in an area protected from the damp.
- Use this manual properly without damaging it.
- Any use of the machine made by operators who are not familiar with the instructions and procedures contained herein shall be forbidden.

This manual is an integral part of the lift: it shall be given to the new owner if and when the lift is resold.

1.2 Obligation In Case Of Malfunction



In case of machine malfunction, follow the instructions contained in the following chapters.

1.3 Cautions For The Safety Of The Operator

Operators must not be under the influence of sedatives, drugs or alcohol when operating the machine.



Before operating the lift, operators must be familiar with the position and function of all controls, as well as with the machine features shown in the chapter "Operation and use"

1.4 Warnings



Unauthorized changes and/or modifications to the machine relieve the manufacturer of any liability for possible damages to objects or people. Do not remove or make inoperative the safety devices, this would cause a violation of safety at work laws and regulations.



Any other use which differs from that provided for by the manufacturer of the machine is strictly forbidden.



The use of non genuine parts may cause damage to people or objects

1.5 Scrapping

When your machine's working life is over and it can no longer be used, it must be made inoperative by removing any connection to power sources. These units are considered as special waste material, and should be broken down into uniform parts and disposed of in compliance with current laws and regulations. If the packing are not polluting or non-biodegradable, deliver them to appropriate handling station.

Declaration Of Warranty And Limitation Of Liability

The manufacturer has paid proper attention to the preparation of this manual. However, nothing contained herein modifies or alters, in any way, the terms and conditions of manufacturer agreement by which this lift was acquired, nor increase, in any way, manufacturer's liability to the customer.

To The Reader

Every effort has been made to ensure that the information contained in this manual is correct, complete, and up-to date. The manufacturer is not liable for any mistakes made when drawing up this manual and reserves the right to make any changes due the development of the product, at any time.

Product Identification

The identification data of the machine are shown in the serial plate placed on the power side column.



Use the identification tag on the lift column to order spare parts and when getting in touch with the manufacturer (inquiry). The removal of this label is strictly forbidden.

Machines may be updated or slightly modified from an aesthetic point of view and, as a consequence, they may present different features from these shown, this without prejudicing what has been described herein.

2.1 Warranty Certificate

The warranty is valid for a period of 12 months starting from the date of the purchase invoice. The warranty will come immediately to an end when unauthorized modifications to the machine or parts of it are carried out. The presence of defects in workmanship must be verified by the Manufacturer's personnel in charge.

2.2 Technical Servicing

For all servicing and maintenance operations not specified or shown in these instructions, contact your Dealer where the machine has been bought or the Manufacturer's Commercial Department.

Packing / Transport / Storage

Only skilled personnel who are familiar with the lift and this manual shall be allowed to carry out packing, lifting, handling, transport and unpacking operations.

3.1 Packing

The packing of the lift is delivered in following components:

- 1 base unit packed in a steel frame, wrapped up in non-scratch material, including all the accessories.
- 1 power unit packed in a carton box.

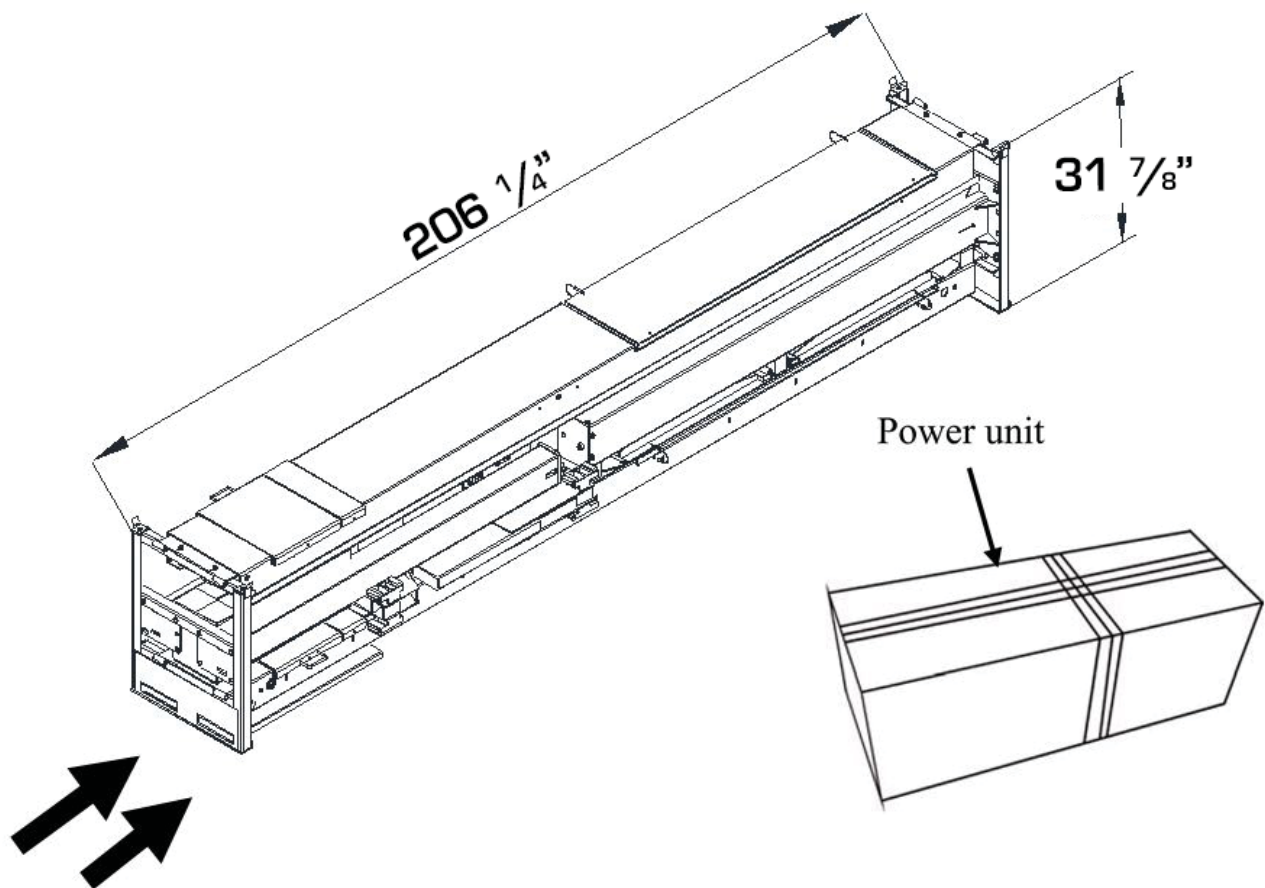

Figure 1 – Package

3.2 Lifting And Handling

When loading/unloading or transporting the equipment to the site, be sure to use suitable loading (e.g. cranes, trucks) and hoisting means. Be sure also to hoist and transport the components securely so that they cannot drop, taking into consideration the package's size, weight and center of gravity and its fragile parts.

3.3 Storage And Stacking Of Packages

Packages must be stored in a covered place, out of direct sunlight and in low humidity, at a temperature between 14°F and 104°F.

Stacking is not recommended: the package's narrow base, as well as its considerable weight and size make it difficult and hazardous.

3.4 Delivery And Check Of Packages

When the lift is delivered, check for possible damages due to transport and storage; verify that what is specified in the manufacturer's confirmation of order is included. In case of damage in transit, the customer must immediately inform the carrier of the problem.

Packages must be opened paying attention not to cause damage to people (keep a safe distance when opening straps) and parts of the lift (be careful the objects do not drop from the package when opening).

Lift Description

The lift is suitable for lifting motor vehicles having maximum weight as described in the nameplate on the power side column of the lift. All mechanical parts have been built in steel plate to make the frame stiff and strong while keeping a low weight. The electro hydraulic operation is described in detail in chapter 8.

This chapter describes the lift's principal elements, allowing the user to be familiar with the machine.

As shown in figure 2, the lift is composed of four columns: N.2 front columns (1), N.2 rear columns (2), two platforms: the power-side platform (3) with the hydraulic cylinder included and the off-side platform (4), and two beams: the front beam (5) and the rear beam (6), anchored to the ground by means of the column base plates.

Raising motion is carried out by pushing the lifting button on the power unit (7) to operate a power unit delivering the hydraulic fluid to cylinders to act on cable lifting system.

Lowering motion is controlled by pushing the lowering lever on the power unit and carried out under the weight of the load lifted.

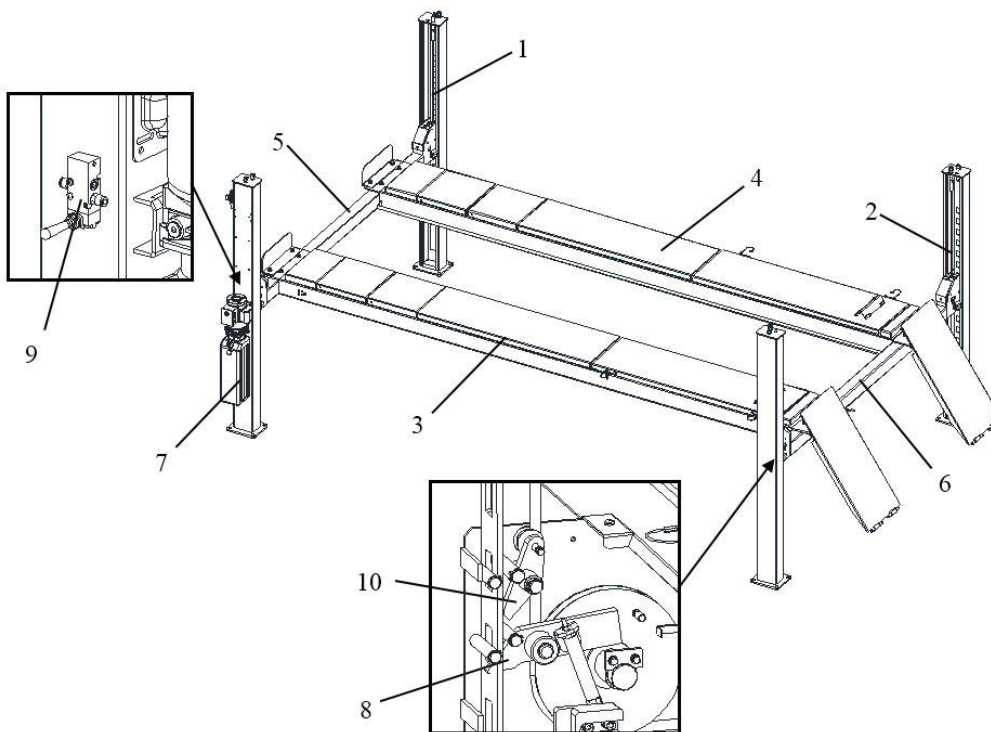

The automatic mechanical back-up safety (8) holds on the lift in the elevated position, can be released by pushing the lever of the control valve (9). The slack cable safety (10) can hold on the lift in event of cable slackening and/or failure.

Figure 2 – Lift

Technical Specification

5.1 Size And Main Features

LIFT CAPACITY	12,000lbs (5500kg)
Maximum raised height	188 5/8" (1974mm)
Min. lowered height	8 3/4" (224mm)
Runway length	194 1/2" (4940mm)
Runway width	20" (510mm)
Free width between runways	43 1/4" (1100mm)
Max. overall length	236 1/2" (6006mm)
Overall height	89 3/4" (2279mm)
Overall width	126 1/8" (3205mm)
Raised time	55s
Noise level	80 dB(A)/1m
Rated pneumatic pressure	6bar – 8bar
Working temperature	5 °C - 40 °C
Average weight of package	3065lbs (1390kg)

5.2 Electric Motor

Voltage	220V/60Hz/1Ph
Power	2.2kw
N° Poles	2
Speed	3450 rpm
Motor enclosure type	B14
Insulation class	IP 54

Motor connection must be carried out referring to the attached wiring diagrams (fig.6).

The motor direction of rotation is shown in the label placed on the motor.

Before use of the lift, make sure to check if the motor specification shown in the nameplate of the motor conforms to the local electric supply.

5.3 Pump

Type	Gear
Flow rate	2.5 cm ³ /g
Continuous working pressure	210 bar

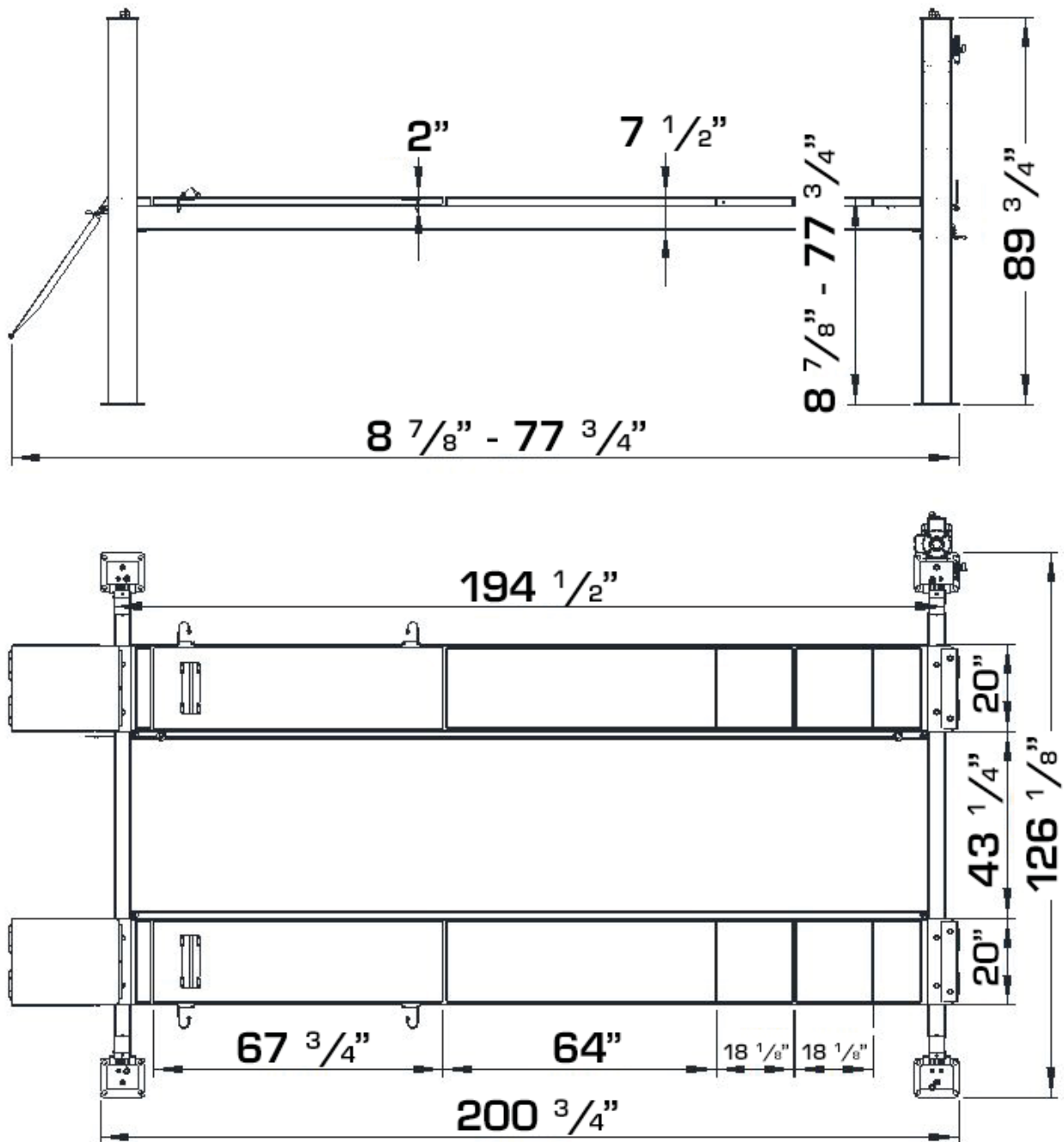

Figure 3 – Lift Layout

5.4 Hydraulic Power Unit

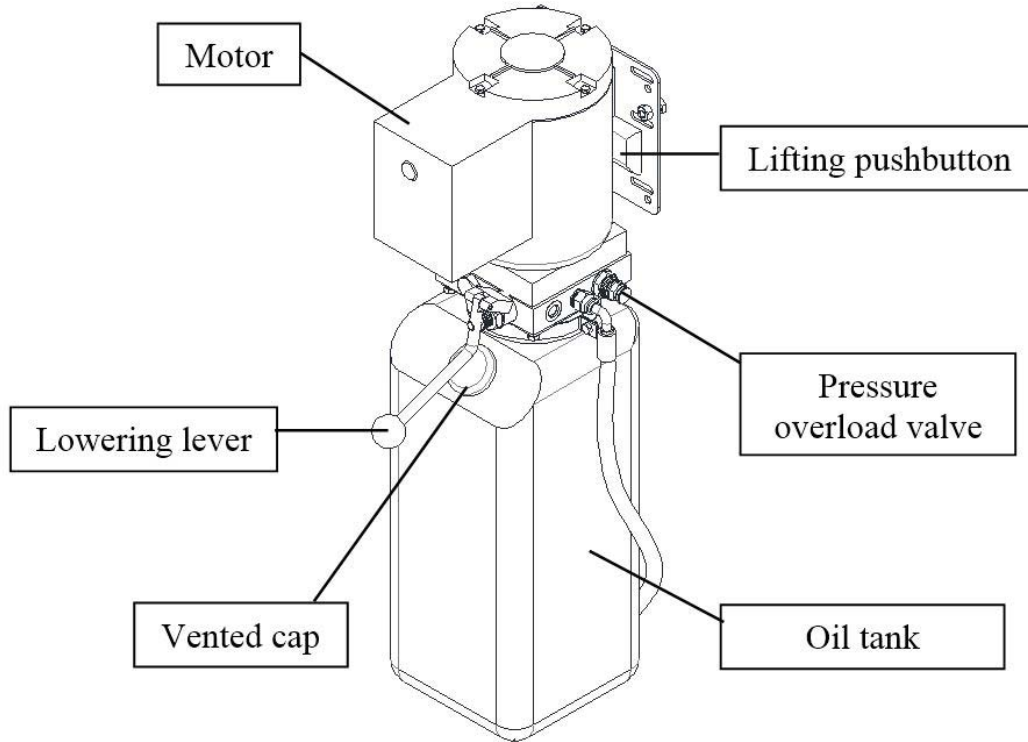

Figure 4 – Hydraulic Power Unit

5.5 Oil

Use wear proof oil for hydraulic drive, in conformity with *ISO 6743/4* rules (HM class). The oil with features similar to those shown in the table is recommended.

Test standards	Features	Value
ASTM D 1298	Density 20°C	0.8 kg/l
ASTM D 445	Viscosity 40°C	32 cSt
ASTM D 445	Viscosity 100°C	5.43 cSt
ASTM D 2270	Viscosity index	104 N°
ASTM D 97	Pour point	~ 30 °C
ASTM D 92	Flash point	215 °C
ASTM D 644	Neutralization number	0.5 mg KOH/g

	Change hydraulic oil at 1 year intervals
---	---

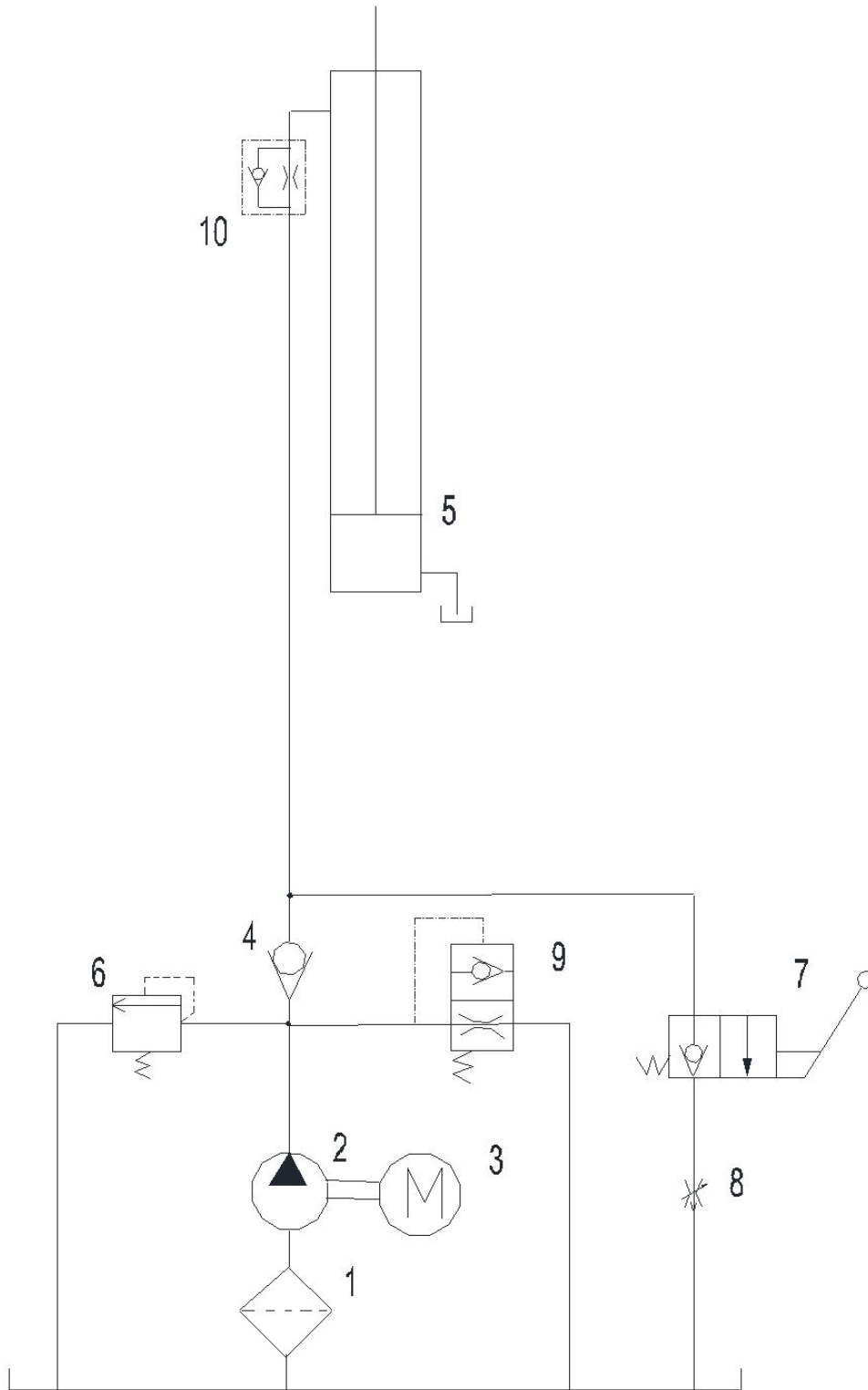

Figure 5 – Hydraulic Plan

1	Oil filter	6	Pressure overload valve
2	Gear pump	7	Manual lowering valve
3	Motor	8	Flow restrictor
4	Non return valve	9	Startup valve
5	Hydraulic cylinder	10	Lowering speed control valve

AC 220V/50Hz/60Hz/1Ph

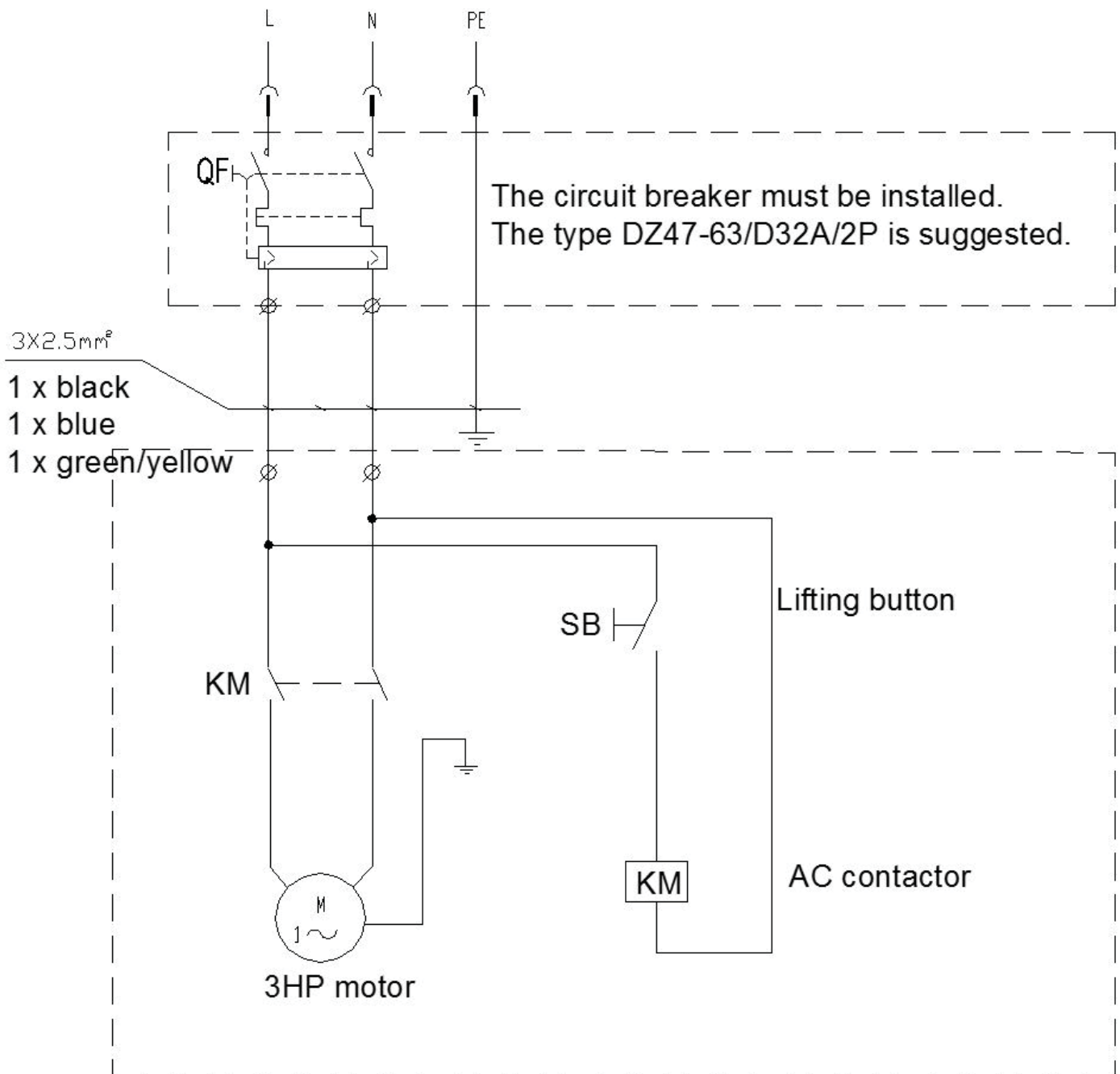

Figure 6 – Electrical Diagram (220V/230V/50Hz/60Hz/1Ph)

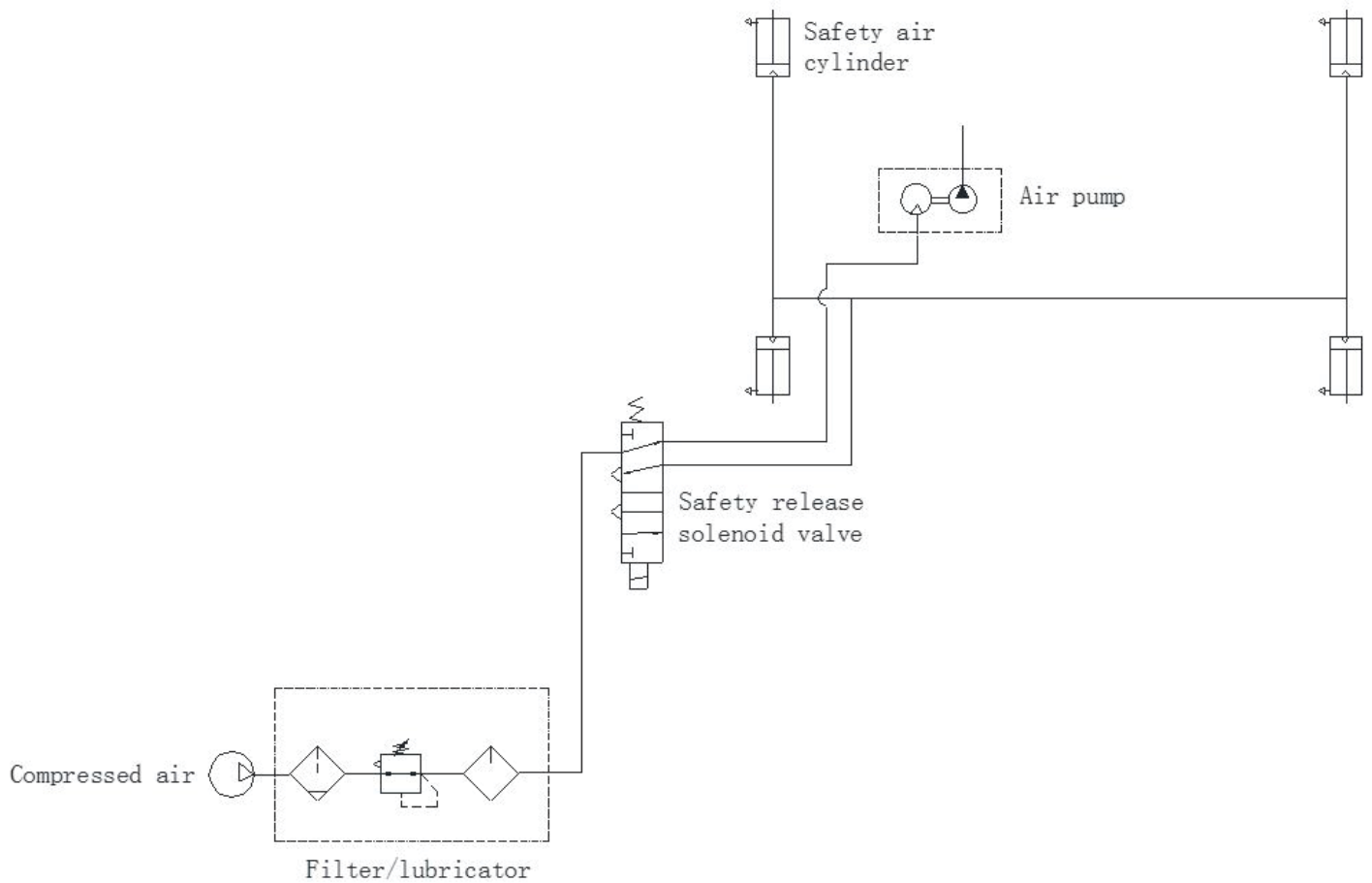

Figure 7 – Pneumatic Plan

	<p>Filter/regulator must be equipped on the air circuit and the air pressure is to be set at 6-8 bar. Filter/regulator is not supplied by the manufacturer if no special order.</p>
---	--

Safety

Read this chapter carefully and completely because it contains important information for the safety of the operator and the person in charge of maintenance.



The lift has been designed and built for lifting vehicles and making them stand above level in a closed area. Any other use is forbidden.
The manufacturer is not liable for possible damages to people, vehicles or objects resulting from an improper or unauthorized use of the lift.

For operator and people safety, a square space for a safety area at least 3 feet free away from the lift must be vacated during lifting and lowering. The lift must be operated only from the operator's control site in this safety area.

Operator's presence under the vehicle, during working, is only admitted when the vehicle is lifted and the safety lock is engaged.



Never use the lift when safety devices are off-line. People, the lift, and the vehicles lifted can be seriously damaged if these instructions are not followed.

6.1 General Warnings

The operator and the person in charge of maintenance must follow accident-prevention laws and rules in force in the country where the lift is installed.



Any use of the lift other than that herein specified can cause serious accidents to people in close proximity of the machine.

They also must carry out the following:

- Neither remove nor disconnect hydraulic, electric or other safety devices;
- Carefully follow the safety indications applied on the machine and included in the manual;
- Observe the safety area during lifting;

- Be sure the motor of the vehicle is off, the gear engaged and the parking brake put on;
- Be sure only authorized vehicles are lifted without exceeding the maximum lifting capacity;
- Verify that no one is on the runways during lifting or standing.

6.2 Risks For People

All risks the personnel could run, due to an improper use of the lift, are described in this section.

6.3 Personnel Crushing Risks

During lowering of runways and vehicles, personnel must not be within the area covered by the lowering trajectory. The operator must be sure no one is in danger before operating the lift.



Fig. 8a

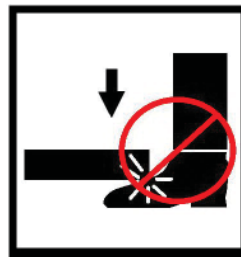

Fig. 8b



Fig. 8c

6.4 Risk Of The Vehicle Falling From The Lift

Vehicle falling from the lift can be caused when the vehicle is improperly placed on platforms, and when its dimensions are incompatible with the lift or by excessive movement of the vehicle.

In this case, keep immediately away from the working area.



Fig. 9a



Fig. 9b



Fig. 9c

6.5 Slipping Risks

The risk of slipping can be caused by oil or dirt on the floor near the lift.

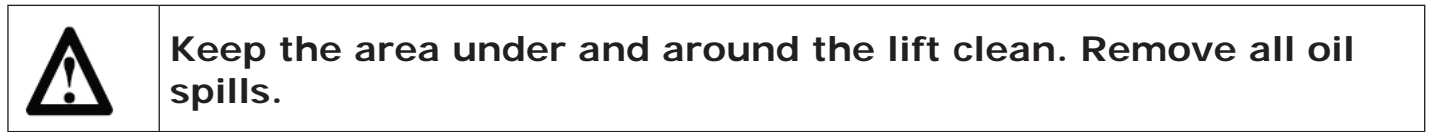

6.6 Electrocuting Risks

Avoid use of water, steam, and solvent, varnish jets in the lift area where electric cables are placed and, in particular, next to the electric panel.



Fig. 10

6.7 Risks Resulting From Improper Lighting

Make sure all areas next to the lift are well and uniformly lit, according to local regulations.

6.8 Risks Of Breaking Component During Operation

Materials and procedures, suitable for the designed parameters of the lift, have been used by the manufacturer to build a safe and reliable product. Operate the lift only for the use it has been designed for and follow the maintenance schedule shown in the chapter "Maintenance".



Fig. 11

6.9 Risks For Unauthorized Uses

The presence of unauthorized persons next to the lift and on the platforms is strictly forbidden during lifting as well as when the vehicle has been already lifted



Fig. 12

6.10 Risks During Vehicle Lifting And Working

To avoid overloading and possible breaking during lifting and working, the following safety devices have been used:

- A pressure valve placed inside the hydraulic unit to prevent excessive weight.



The maximum pressure valve has been preset by the manufacturer to a proper pressure. DO NOT try to adjust it to overrun the rated lifting capacity.

- Automatic mechanical back-up safety holds on the lift in the elevated position.
- Slack safety in event of cable slackening and/or failure.



It is strictly forbidden to modify any safety device. Always ensure the safety device for proper operation during the service.

Installation



Only skilled technicians, appointed by the manufacturer, or by authorized dealers, must be allowed to carry out installation. Serious damage to people and to the lift can be caused if installations are made by unskilled personnel. Always refer to the exploded views attached during installation.

7.1 Tool Required

Rotary Hammer Drill D.16	Hex-Key/Allen Wrench Set
Masonry Bit	Crow Bar For Shim Installation
Hammer	Chalk Line
Level	Medium Cross Screwdriver
Open-End Wrench Set	Medium Flat Screwdriver
Medium Crescent Wrench	Tape measure

7.2 Checking For Room Suitability

The lift has been designed to be used in covered and sheltered places.

The place of installation must not be next to washing areas, painting workbenches, solvent or varnish deposits. The installation near to rooms where a dangerous situation of explosion can occur, is strictly forbidden. The relevant standards of the local Health and Safety at Work regulations, for instance, with respect to minimum distance to wall or other equipment, must be observed.

7.3 Lighting

Lighting must be carried out according to the effective regulations of the place of installation. All areas next to the lift must be well and uniformly lit.

7.4 Installation Surface

The lift MUST be installed on 3000 PSI concrete with the minimum thickness 6" and an extension of at least 4 feet from anchoring points.

New concrete must be adequately cured by at least 21 days minimum.



A level floor is suggested for proper installation. Small differences in floor slope may be compensated for by proper shimming. Any major slope change will affect the level lifting performance. If a floor is of questionable slope (more than 3 degrees), considering to pour the new concrete slab.

7.5 Positioning Lift

- Determine which end of the lift will be approach side.
- Determine which side the power-side runway (with the hydraulic cylinder attached) will be located on. Remember that the power-side runway must be installed on the same side as the power-side column.

7.6 Attaching Runways To Rear Beam



It is important to position the power-side runway (with the hydraulic cylinder) on the same side as the power unit location.

The rails on each side must be installed to the inside.

Elevate runways off the floor with blocks of wood to prevent any damage.

Pay attention that "T" fitting for air supply is closest to the power side of the lift.

- Unpack the lift by removing all wrapping films.
- Place each runway in the predetermined location. Make sure that the rails on each side must be installed to the inside. Pay attention to the location of the power-side runway.
- Place the front and rear transverse beams on each ends of runways. The runways and transverse beams should be laid out as shown in figure 13. Make sure the

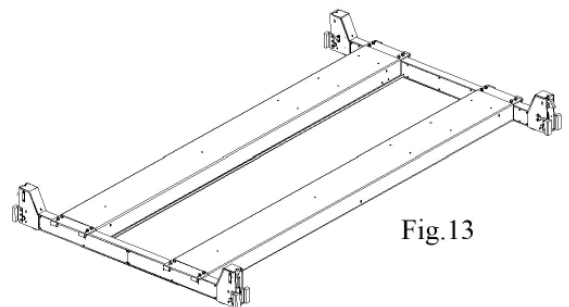

accessories are installed in the runways before installation. Make sure that the plastic slide blocks are in position.

- Remove all covers on transverse beams.
- Slide the steel cables from the end of power-side runway and route the cables through the transverse beams referring to the routing diagram (fig. 14). Make sure that the cables are not twisted during routing and routed on the correct pulleys in runways.

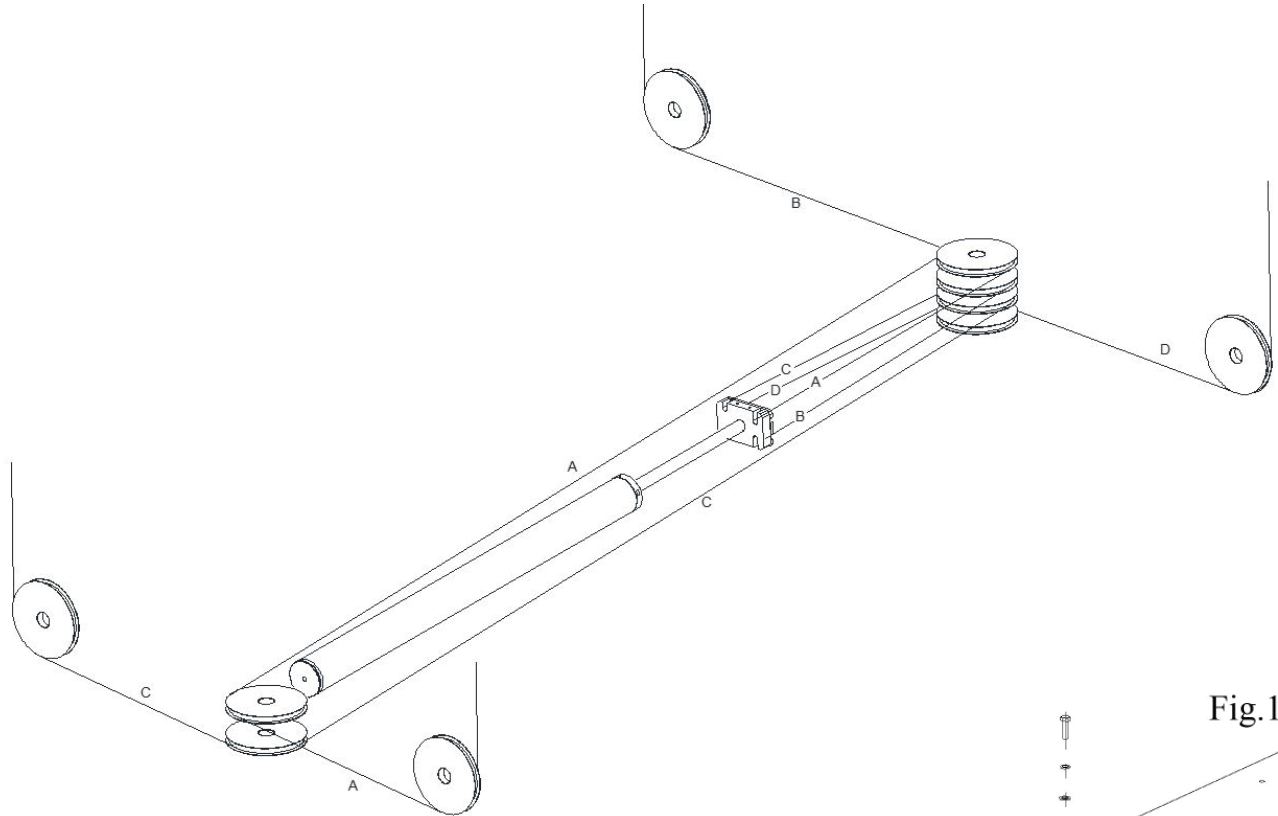

Figure 14 – Cable Routing Diagram

- Line up the runways with the bolt holes in the transverse beams and temporarily bolt the screw M16X50 with the nut M16, washer D.16 and locking washer D.16 in position as shown in the figure 15.
- Make sure the cables are routed correctly as shown in the figure 16 and make sure that cables are on the safety rollers.

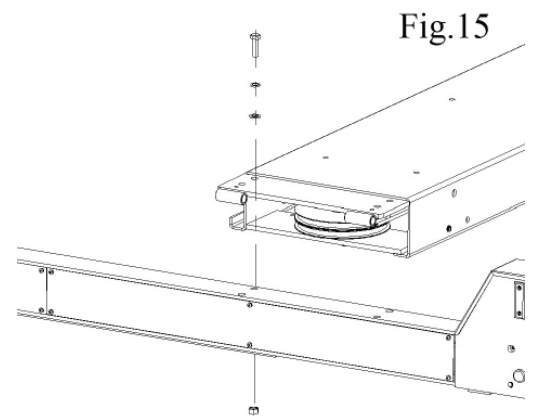

Fig.15

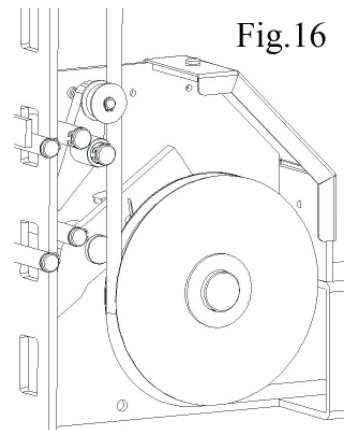



Fig.16

	<p>Before installation, make sure that all accessories have been installed in the runways and transverse beams.</p>
---	--

7.7 Installation Of Columns

- Transport the columns to the located site.
- Move each column toward the respective end of the transverse beam until stopped by the slide block on the transverse beam. Make sure that all columns are positioned in the correct location . Make sure to use caution to prevent columns from falling over. If necessary, use the shims.
- Slide the safety rack down inside each column. Make sure to slide the rack through the groove of the slide blocks.
- Assemble the nut M20 (1/fig.17) to the adjustment rod (2/fig.17).
- Insert the rod through top of the column and screw it into the safety rack.
- Insert the steel cable through top of the column and assemble the locking nut M22 (3/fig.17) and washer D.22 (4/fig.17).
- Adjust each rack in equal height by tightening or unloosing the nuts.
- Adjust each cable in equal tension by tightening or unloosing the nuts.

Fig. 17

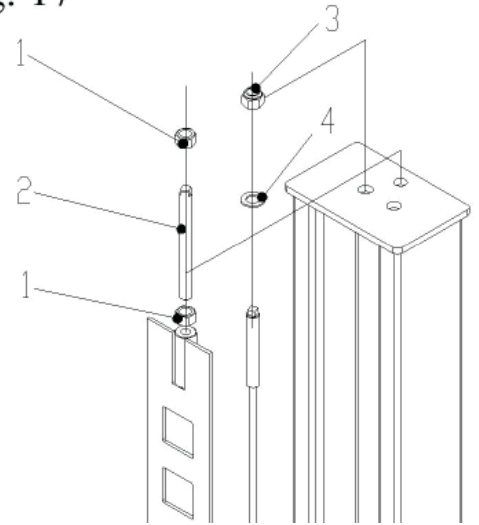

Each cable must be routed through the column hole toward to the lift center. The lift cannot work properly and thus damage the cable if failure to do so.

7.8 Anchoring Columns

- Before proceeding, check the measurement and make sure that the base plate of each column is square.
- Using the base plate as guide, drill each hole in the concrete approximately 6" deep with the rotary hammer drill D.19. To assure full holding power, do not ream the hole or allow drill to wobble.
- After drilling, remove dust thoroughly from each hole using compressed air or wire brush.
- Assemble the washers and nuts on the anchors then tap into each hole with a hammer until the washer rests against the base plate. Be sure if shimming is required, enough threads are left exposed.

- If shimming is required, insert the shims as necessary around the anchor bolts, the columns will be plumb.
- With the shims and anchor bolts in place, tighten by securing the nut to the base.

7.9 Hydraulic System Connection



When routing the hydraulic hose, make sure that the hose is clear of any moving part, make sure to keep the hose and fittings clean from dust.

- Fix the hydraulic power unit onto the support mounted on the power-side column using the supplied 2 screws M20X20, washers D.20 and locking washers D.20 as shown in the figure 18.
- Route the hydraulic hoses referring to the figure 19.
- Tighten the fittings thoroughly.

Fig. 18

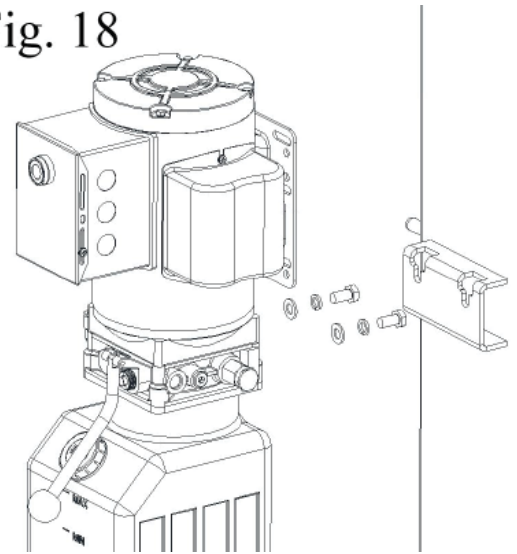
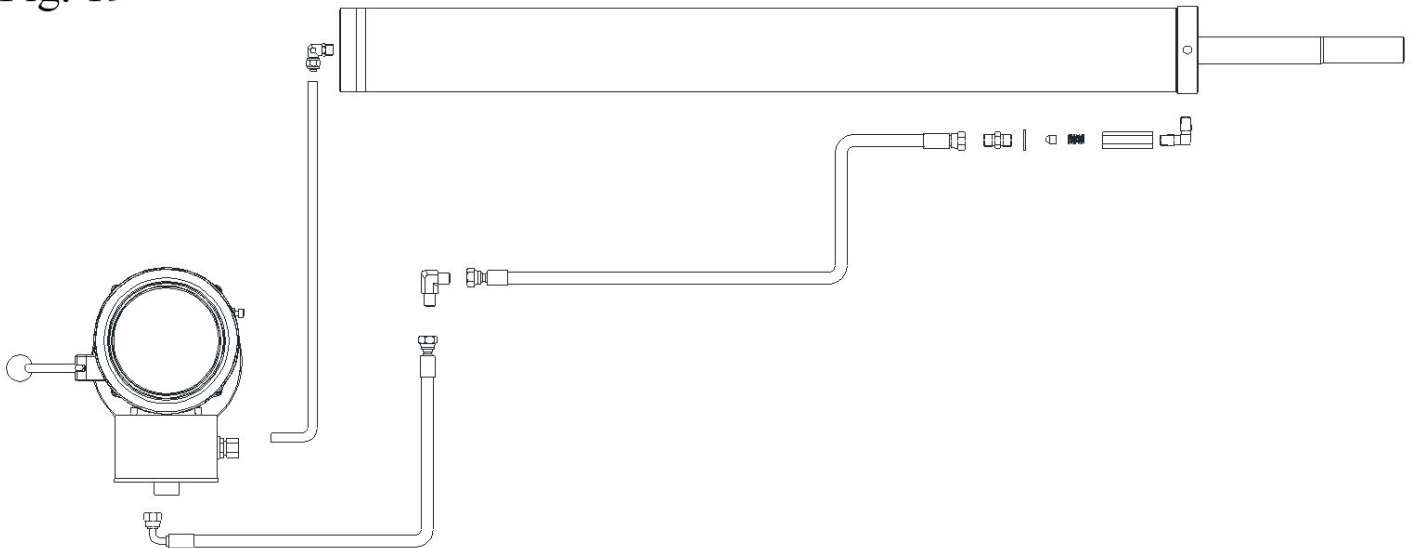

Fig. 19



7.10 Pneumatic System Connection



When routing the air tubes, make sure that the tubes are clear of any moving part. It may be necessary to tie the hoses clear by using nylon tie straps or wire. Failure to do so may result in safety failure which may result in damage or personal harm.

Filter/regulator must be equipped on the air circuit and the air pressure is to be set at 6-8bar.

The pneumatic supply at site (to which the pneumatic system of the lift is connected) must be equipped with a servicing unit composed of water separator, lubricator and pressure reducer. These devices can be supplied by the manufacturer on request.

For the connection of the pneumatic lines proceed as follow:

- Install the control valve on the motor bracket using screws M4X30 (ref. fig. 20).
- Connect the pneumatic lines referring to the diagram (fig.21);
- Connect the air valve to the pneumatic supply at site.
- Check for the air leaks by depressing the air valve.

Fig. 20

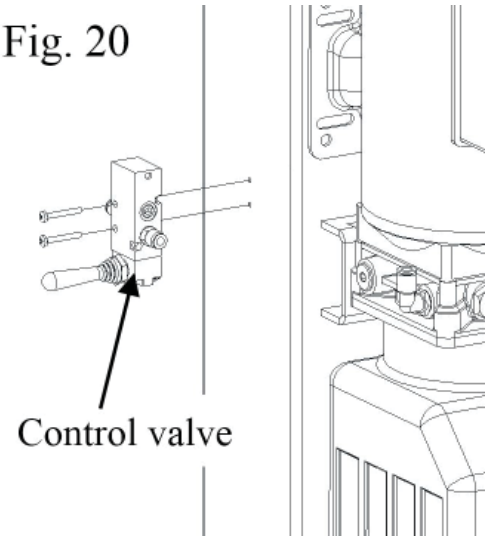

Fig. 21

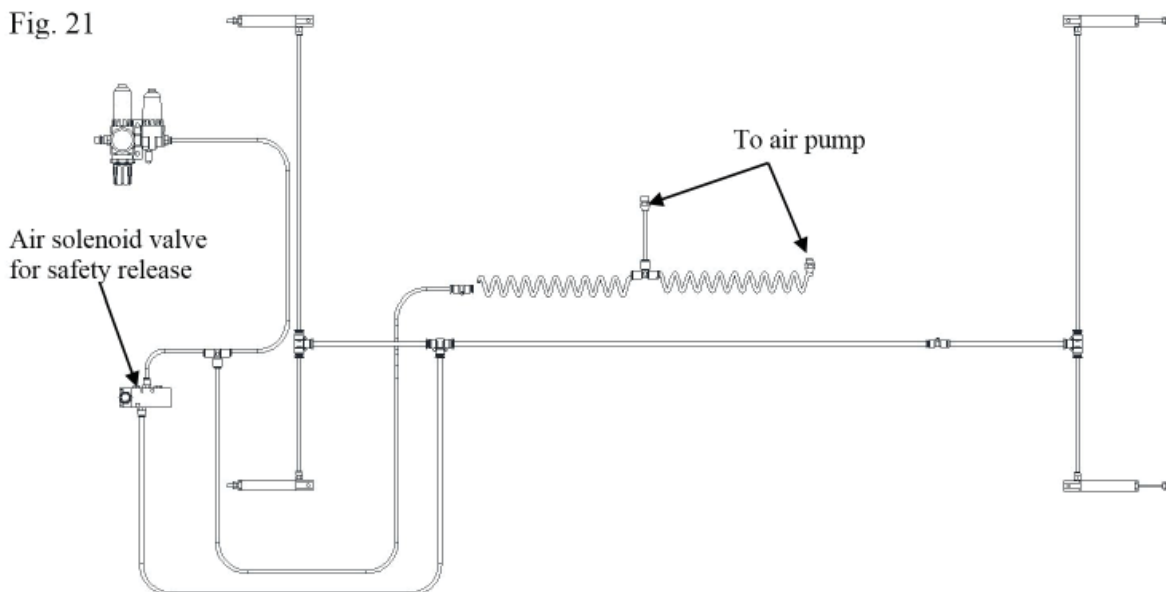

Figure 21 – Pneumatic Line Connection

7.11 Make The Electrical Hookup To The Power Unit



The hookup work must be carried out by a qualified electrician. Make sure that the power supply is right. Make sure the connection of the phases is right. The power unit must be kept dry.



It is strictly forbidden to use 60Hz motor on 50Hz power supply. Never operate the motor on the power less than 208V. Motor damage may occur.

- Make the electric hookup to the hydraulic power unit referring to the wiring diagram (fig. 6);
- Make sure to install a proper circuit breaker on the circuit (DZ47-63/ D32A/2P is suggested for single phase 208-240V).
- Make sure the lift is grounded well.

7.12 Oil Filling And Bleeding



DO NOT run power unit without oil. Damage to pump can occur.
If motor gets hot or sounds peculiar, stop immediately and recheck the electric connection.

- Use the hydraulic fluid recommended in the chapter 5.5.
- Remove the oil level plug on the oil tank and pour oil in the tank about 12 liters.
- Raising the lift slowly by pressing the lifting button until the lift reaches the full height. DO NOT continue pressing button after lift reaches full height. Damage to motor can occur if continued.
- Repeat raise and lower the lift completely at least 3 times to bleed the trapped air inside the cylinder.



If the oil level plug is lost or broken, order the replacement. The oil tank must be vented well.

7.13 Check Before Start-Up



During START UP procedure, observe all operating components and check for proper installation and adjustment. DO NOT attempt to raise vehicle until a thorough operation check has been completed.

7.13.1 General Checks

- Make sure to check that the columns are plumb;
- Make sure to check the lift anchored to the ground and all anchor bolts tightened.
- Make sure to check the electrical system feeding voltage is equal to that specified in the nameplate on the motor;
- Make sure to check the electric system connection in conformity of the electric plan shown as the electric diagram (fig. 6) and for proper grounding.
- Make sure to check all plastic sliders are on the position and greased properly.
- Make sure to check all pins are installed correctly and greased properly.
- Make sure to check all bolts, nuts and screws are tightened securely.

Particularly, below checks must be followed:

7.13.2 Cable For Proper Installation

- Check to make sure that all cables are routed correctly and are on the correct pulleys.
- Check that all cables are adjusted in the same tension and the lift can be raised evenly. If not, make the adjustment.



There will be some initial stretching of the cables in the beginning. It will be necessary to re-adjust the cables a week after the first week, then three months thereafter. Failure to do this will cause uneven lifting.

7.13.3 Safety Lock For Proper Installation

- Check to make sure that all air hoses are connected properly and the air pressure is set to 6-8bar.
- Check to make sure that the control valve for proper operation.
- Check if four latches are engaging uniformly. If not, make the adjustment.

7.13.4 Hydraulic System For Proper Operation

- Proper oil level in the tank, refill if needed.
- Raise the lift to the full height and keep the motor running for 5 seconds and check all hoses connections no leakage. Tighten the connections or reseal if necessary.
- Check the lift for reaching its maximum height.

	If the vented cap is lost or broken, order the replacement. The oil tank must be vented well.
---	--

7.14 Check With Load

	WARNING: please follow carefully the instructions in the coming paragraph for avoiding damages on the lift.
---	--

Carried out two or three complete cycles of lowering with the vehicle loaded and lifting and:

- Repeat the checks provided for by 7.15.
- Check no strange noise during lifting and lowering.
- If the runways weren't leveled, readjust.

7.15 Installation Of Jacking Beam (Optional)

This jacking beam is designed to be equipped with a 4 post lift. The maximum capacity is 3200kg (7000lbs).

To install the jacking beam on a 4 post lift, do as followings.

- Lower the lift fully.
- Lower the jacking beam all the way down.
- Use a proper hoist equipment to place the jacking beam on rails inside runways of the lift.

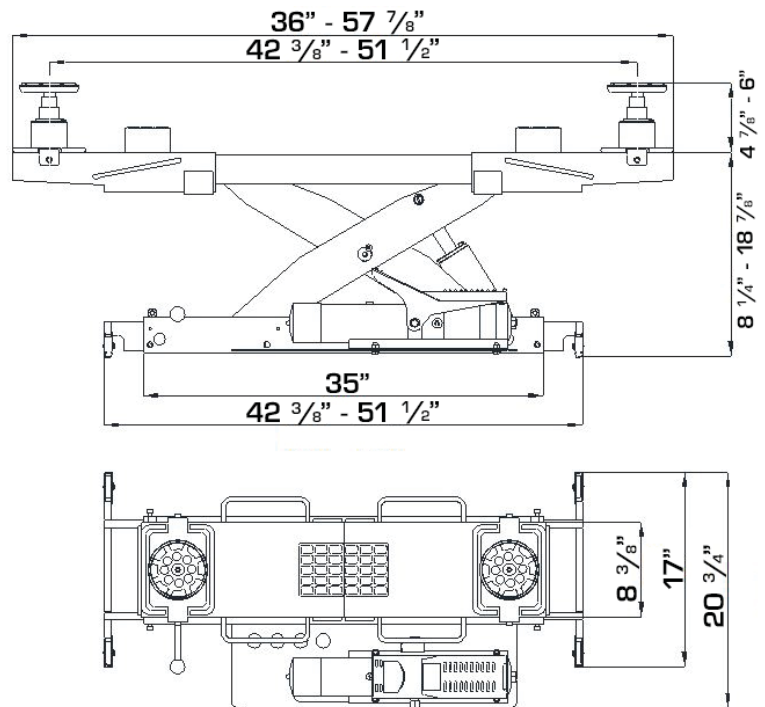

Figure 22 – Jacking Beam Layout

- Adjust the base to the correct width.
- Check to make sure that all four rollers are seated properly on rails as shown in the fig.23.
- Make sure that rail channel is clean of debris.
- Raise the lift up off the ground so that the jacking beam is off the ground.
- Check the clearance and movement of the jacking beam by sliding it forward and rearward on the rails. Check all rollers are centered on the rails at all points along the rail's length. Width adjustment of the jack base may be necessary to ensure the proper operation.
- Connect the pneumatic line following the fig.7 and the instructions described in the chapter 7.13.
- Connect the hydraulic hose following the figure 24.
- Fill the pump reservoir with the oil suggested in the chapter 5.5.

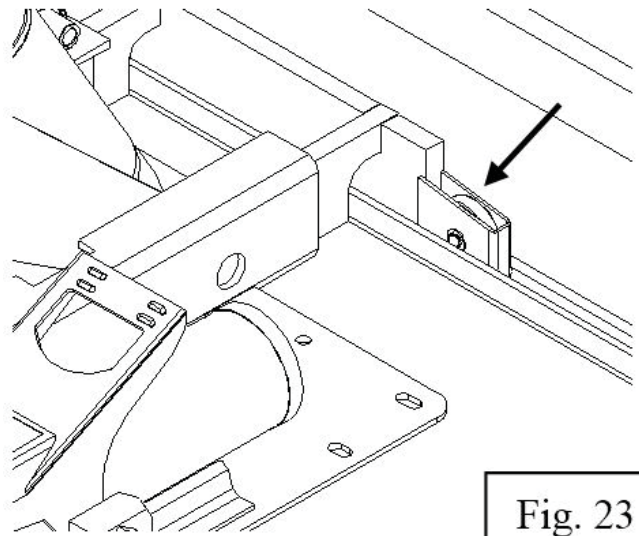

Fig. 23

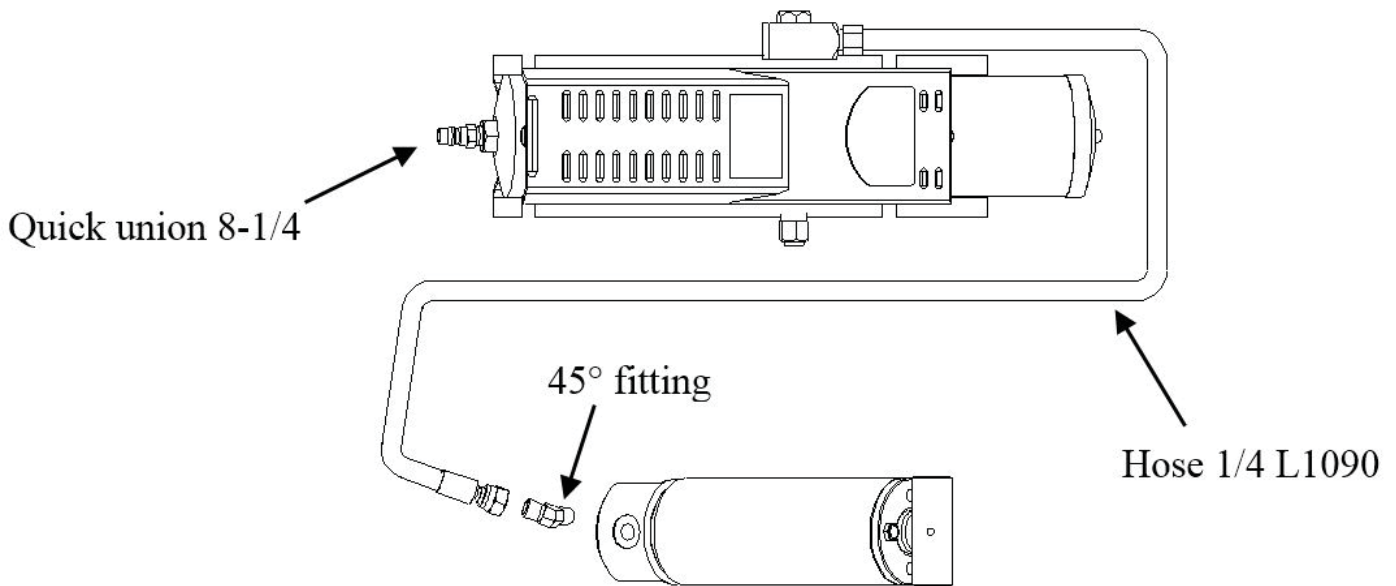
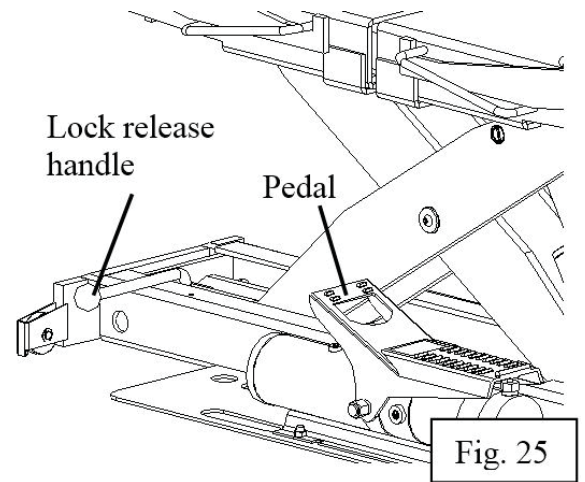

Figure 24 – Hydraulic Line Connection Of Jacking Beam

- Without a vehicle loaded, depress the pedal of the pump to raise the jack at full stroke to check for the proper operation.
- Check for the first lock operation by lowering the jack to the first lock position (about 18" high) and then raising the jack to clear off the lock and in the meantime flipping the lock release handle up off the lock.
- Check for the second lock operation by lowering the jack to the second lock position (about 14" high) and then raising the jack to clear off the lock and in the meantime flipping the lock release handle up off the lock.



Operation And Use



Never operate the lift with any person or equipment below.

Never exceed the rated lifting capacity.

Always ensure that all latches are engaged well before any attempt is made to work on or near the vehicle.

Never leave the lift in an elevated position unless the safeties are engaged.

If an anchor bolt becomes loose or any component of the lift is found to be defective, DO NOT USE THE LIFT until repairs are made.

8.1 Controls Of Lift

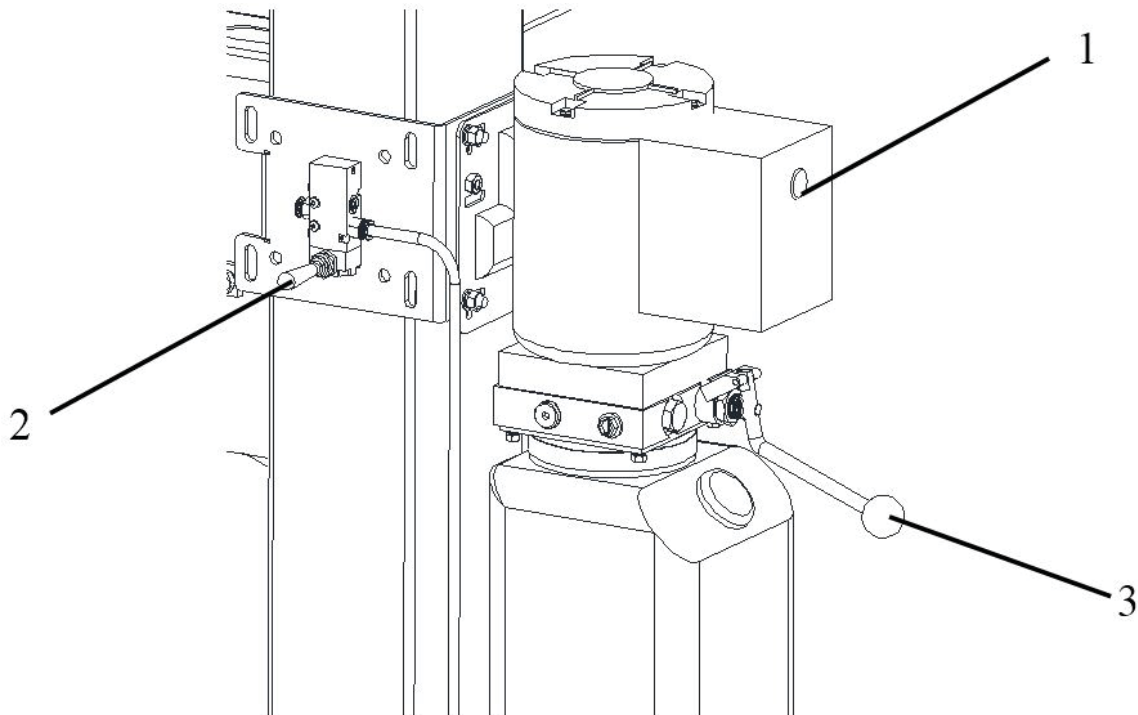

Figure 26 – Controls Of Lift

Controls for operating the lift are:

LIFTING BUTTON (1)

- When pressed, the power unit is running and the lift can be raised to a desired height until the button is released.

AIR CONTROL VALVE (2)

- When pressed, the lock latches will be released so that the lift can be lowered.

LOWERING HANDLE (3)

- When the air control valve is not pressed, press the lowering handle to lower the lift to engage the nearest latch rack.
- When the latches are released by pressing the air control valve, press the lowering handle in the meantime to lower the lift to the desired height under its weight and the load lifted until the handle is released.

Lift operation can be summarized into three steps:

8.1.1 Lifting

- Pay attention to overhead clearance;
- The lift must be fully lowered and no one in the service area while the vehicle is driven onto the lift;
- Position the wheels in center of each runway;
- Stop the vehicle when it contacts the front stops or at the desired position;
- Set the parking brake or place the wheel chocks on each side of the rear wheels;
- Make sure the all personnel must be exit before the lift is raised;
- Raise the lift by pushing the lifting button until reaching the desire height.

8.1.2 Standing

- Press the lowering handle to engage the nearest latch position;
- Always ensure that the latch in each column is engaged before any attempt is made to work on or near the vehicle.

8.1.3 Lowering

- Be sure the safety area is free of people and objects;
- Raise the lift high enough by pushing the lifting button to clear off the locks;
- Lower the lift by pressing both the air control valve and the lowering handle;
- Observe the lift and the vehicle to be sure the lift is level while being lowered;
- Lower the lift fully;
- Remove the wheel chocks and check to be sure that the area is clear before removing the vehicle off the lift.

Maintenance



Only trained personnel who knows how the lift works, must be allowed to service the lift.

To service properly the lift, the following has to be carried out:

- Use only genuine spare parts as well as equipment suitable for the work required;
- Follow the scheduled maintenance and check periods shown in the manual;
- Discover the reason for possible failures such as too much noise, overheating, oil blow-by, etc.
- Refer to documents supplied by the manufacture or dealer to carry out maintenance.



Before carrying out any maintenance or repair on the lift, disconnect the power supply, padlock the general switch and keep the key in a safe place to prevent unauthorized persons from switching on or operating the lift.

9.1 Ordinary Maintenance

The lift has to be properly cleaned at least once a month using self-cleaning clothes.



The use of water or inflammable liquid is strictly forbidden.

Be sure the rod of the hydraulic cylinders is always clean and not damaged since this may result in leakage from seals and, as a consequence, in possible malfunctions.

9.2 Periodic Maintenance

Daily pre-operation	<ul style="list-style-type: none">• Check hydraulic connections and hoses for leaks• Check air connections and hoses for leaks• Check safety lock audibly and visually while in operation• Check bolts, nuts and screws are tight
Every 1 month	<ul style="list-style-type: none">• Check all cable connections, pins and bolts to insure proper mounting• Check all anchor bolts and retighten if necessary• Check columns for square-ness and plumb• Check steel cable tension, adjust if necessary• Check all lifting pads, replace if necessary• Lubricate sliders with grease• Lubricate all pivot pins• Check the hydraulic oil, fill or replace if necessary• Check hydraulic systems for proper operation
Every 12 months	<ul style="list-style-type: none">• Verify that all components and mechanisms are not damaged• Verify the equalizer cables are not worn, change if necessary• Check the electrical system to verify that the motors operate properly (this work must be carried out by skilled electricians)• Empty the oil tank and change the hydraulic oil

Troubleshooting

A list of possible troubles and solutions is given below

Trouble:	Possible Cause:	Solution:
The lift does not work	There is no power	Check Power on to restore if necessary
	The electrical wires are disconnected	Reconnect
	The circuit breaker are blown	Check for correct voltage Replace
The lift does not raise	The lift is overloaded	Check the vehicle weight
	The motor direction of rotation is not correct.	Interchange the two phases on the main switch
	The oil in the power unit is not sufficient.	Add some hydraulic oil
	The UP button is faulty.	Check UP button and connection for proper operation. Replace if needed
	The lowering valve does not close.	Check and clean, if dirty or replace if faulty
	The suction tube or pump filter is dirty.	Check and clean if needed.
	Presence of air in the hydraulic system	Bleed the hydraulic system
The lifting capacity is not sufficient	The pump is faulty	Check the pump and replace if needed.
	Oil leakages in hydraulic circuit	Check the circuit for any leakage
The lift does not lower when the lowering lever and the safety release lever are pressed	The lowering valve does not work properly	Check the valve and replace if needed.
	Air control valve does not work	Check the valve and replace if needed.
The lift does not lower smoothly	Presence of air in the hydraulic system	Bleed the hydraulic system
	Lubrication of sliders is not enough.	Grease
	Sliders are damaged	Replace

Parts List

Lift

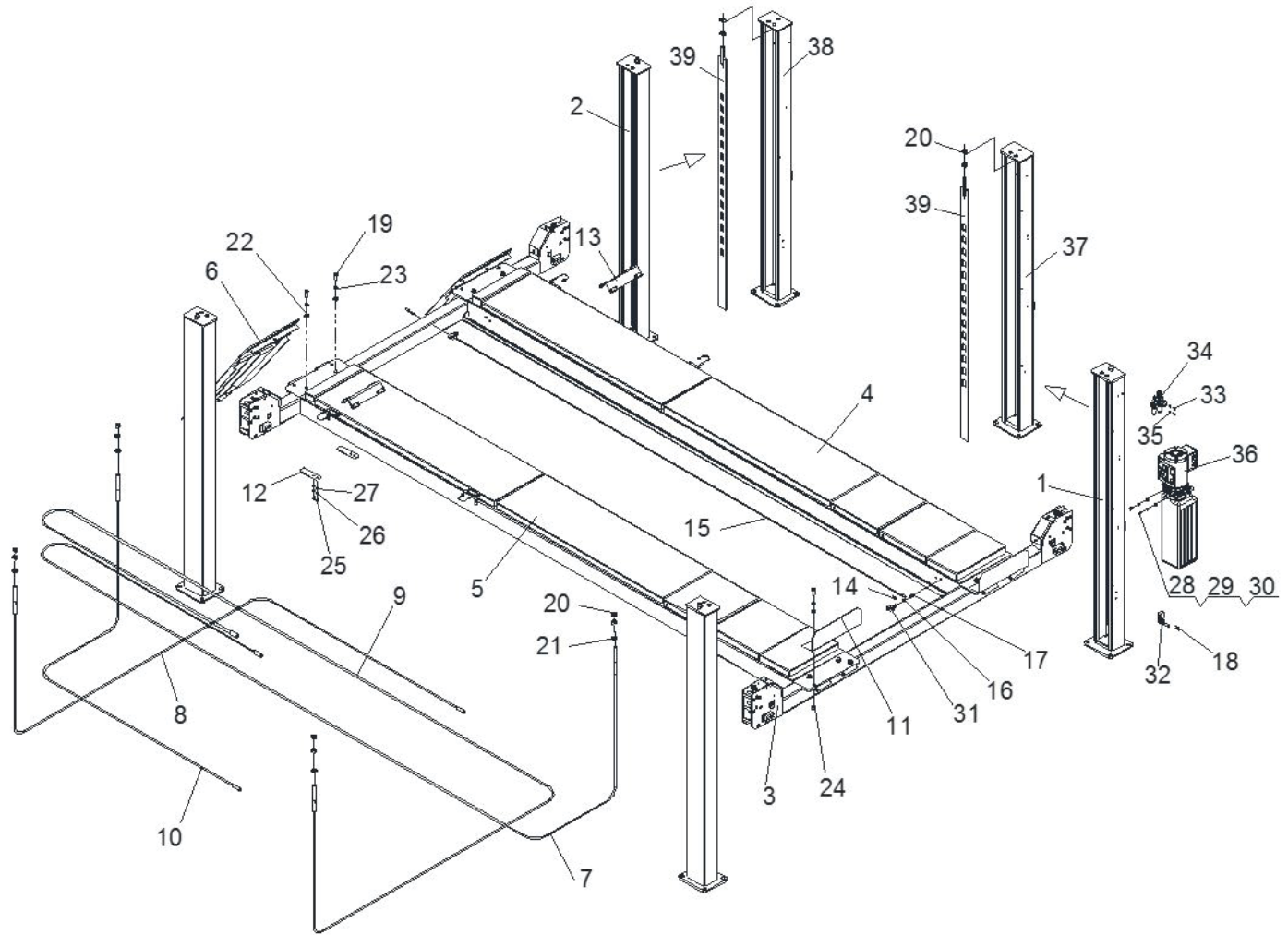

Lift			
ITEM	PART NO.	DESCRIPTION	QTY
1	Z75A110000	Power-side column	1
2	Z75A120000	Off-side column	3
3	Z75A200000	Transverse beam assembly	2
4	Z75A310000	Power-side platform assembly	1
5	Z75A320000	Off-side platform assembly	1
6	Z75A810000	Drive-on ramp assembly	2

Lift			
ITEM	PART NO.	DESCRIPTION	QTY
7	Z75A850100	Steel cable A L=8675	1
8	Z75A850200	Steel cable B L=5390	1
9	Z75A850300	Steel cable C L=10285	1
10	Z75A850400	Steel cable D L=3780	1
11	Z72E310002	Wheel stop plate	2
12	Z72E310011	Protective plate	4
13	Z72A300100	Wheel chock	2
14	0215085	Wire clamp	2
15	0604001	Cable L=5400	1
16	0205013	Washer D.12 - GB/T97.1	2
17	0203023	Nut M12 - GB/T6170	2
18	0206018	Screw M4X30 - GB/T818	2
19	0201130	Screw M16X40 - GB/T5783	12
20	0203012	Nut M20 - GB/T6170	16
21	0205022	Washer D.20 - GB/T97.1	4
22	0205020	Washer D.16 - GB/T97.1	12
23	0208011	Locking washer D.16 - GB/T93	12
24	0203025	Nut M16 - GB/T6170	4
25	0201026	Screw M8X16 - GB/T5783	8
26	0208006	Locking washer D.8 - GB/T93	8
27	0205008	Washer D.8 - GB/T97.1	8
28	0201062	Screw M10X20 - GB/T5783	2
29	0205011	Washer D.10 - GB/T97.1	2
30	0208007	Locking washer D.10 - GB/T93	2
31	0215028	Bolt M12 - GB/T825	2
32	0306258	Air control valve	1
33	0206025	Screw M5X18 - GB/T818	2
34	0306179	Filter regulator	1
35	0204002	Self-locking nut M5 - GB/T889.1	2
36	0302012	Hydraulic power unit	1
37	Z75A111000	Post A	1
38	Z75A121000	Post B	3
39	Z72E122000	Safety rack	4

Transverse Beam

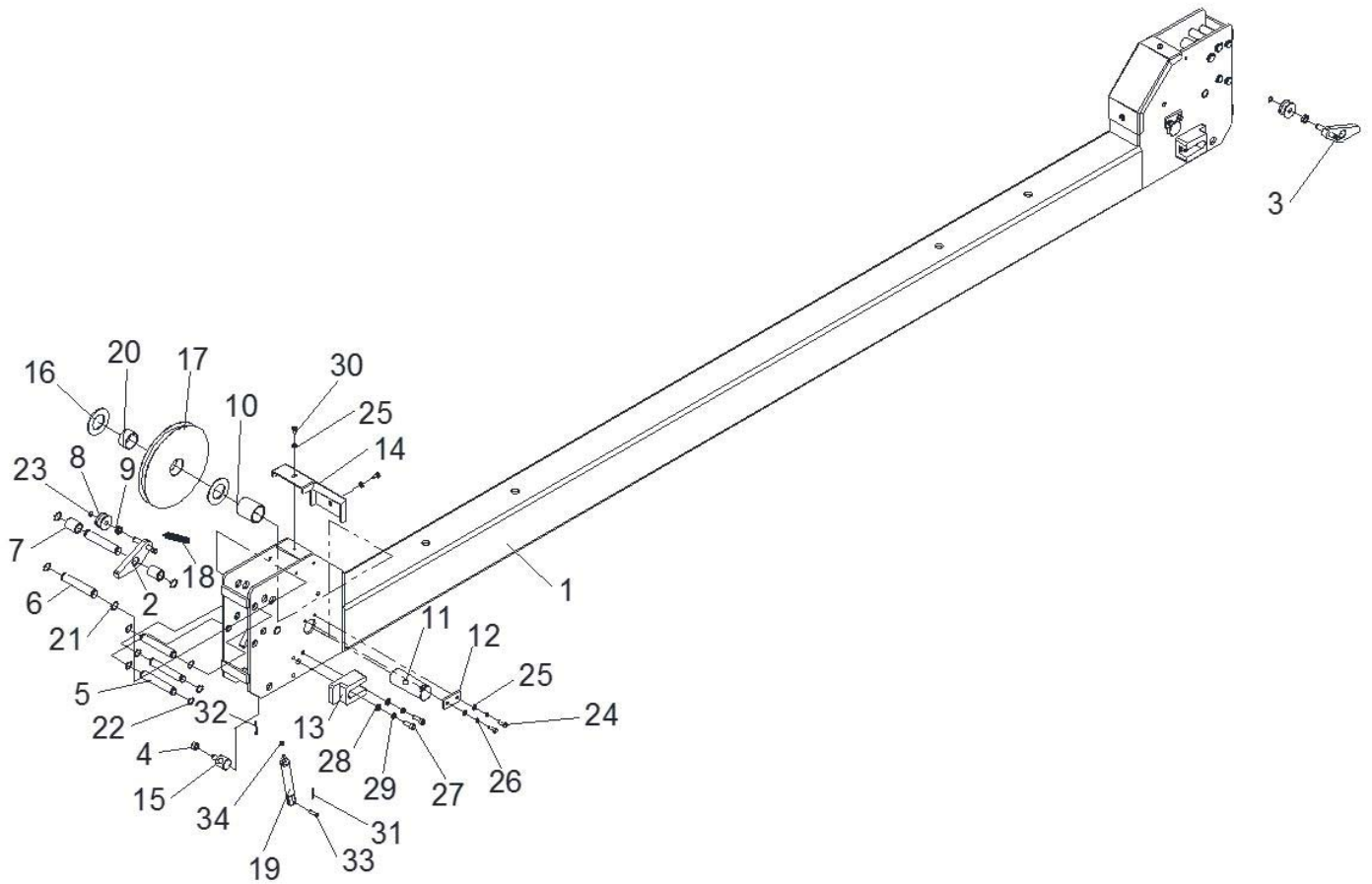

Transverse Beam			
ITEM	PART NO.	DESCRIPTION	QTY
1	Z75A210000	Transverse beam	1
2	Z72E220000	Safety pawl A	1
3	Z72E230000	Safety pawl B	1
4	0203011	Nut M10 - GB/T6170	2
5	Z72E200001	Shaft 1	6
6	Z72E200002	Shaft 2	4
7	Z72E200003	Bush	4
8	Z72E200004	Nylon roller	2
9	Z72E200005	Spacer	2
10	Z72E200006	Bush	2
11	Z72E200007	Shaft 3	2
12	Z72E200008	Protective plate	2

Transverse Beam

ITEM	PART NO.	DESCRIPTION	QTY
13	Z72E200009	Slider	4
14	Z72E200010	Protective cover	2
15	Z72E200011	Shaft 4	2
16	Z72E310003	Washer	4
17	Z72E310004	Cable pulley	2
18	Z71P211811	Spring	2
19	0306293	Safety release air cylinder 16X40	2
20	0210021	Bush 3520/SF-1	2
21	0212016	Seeger D.18	8
22	0212002	Seeger D.16	12
23	0212013	Seeger D.10	2
24	0201013	Screw M6X16 - GB/T5783	4
25	0205006	Washer D.6 - GB/T97.1	8
26	0208005	Spring washer D.6 - GB/T93	4
27	0202045	Screw M8X20 - GB/T70.1	8
28	0205008	Washer D.8 - GB/T97.1	8
29	0208006	Locking washer D.8 - GB/T93	8
30	0206040	Screw M6X12 - GB/T818	4
31	0213044	Split pin 2X20 - GB/T91	2
32	0213038	Split pin 2.5X26 - GB/T91	2
33	0213134	Pin 5x22	2
34	0204002	Self-locking nut M5	2

Power-Side Runway

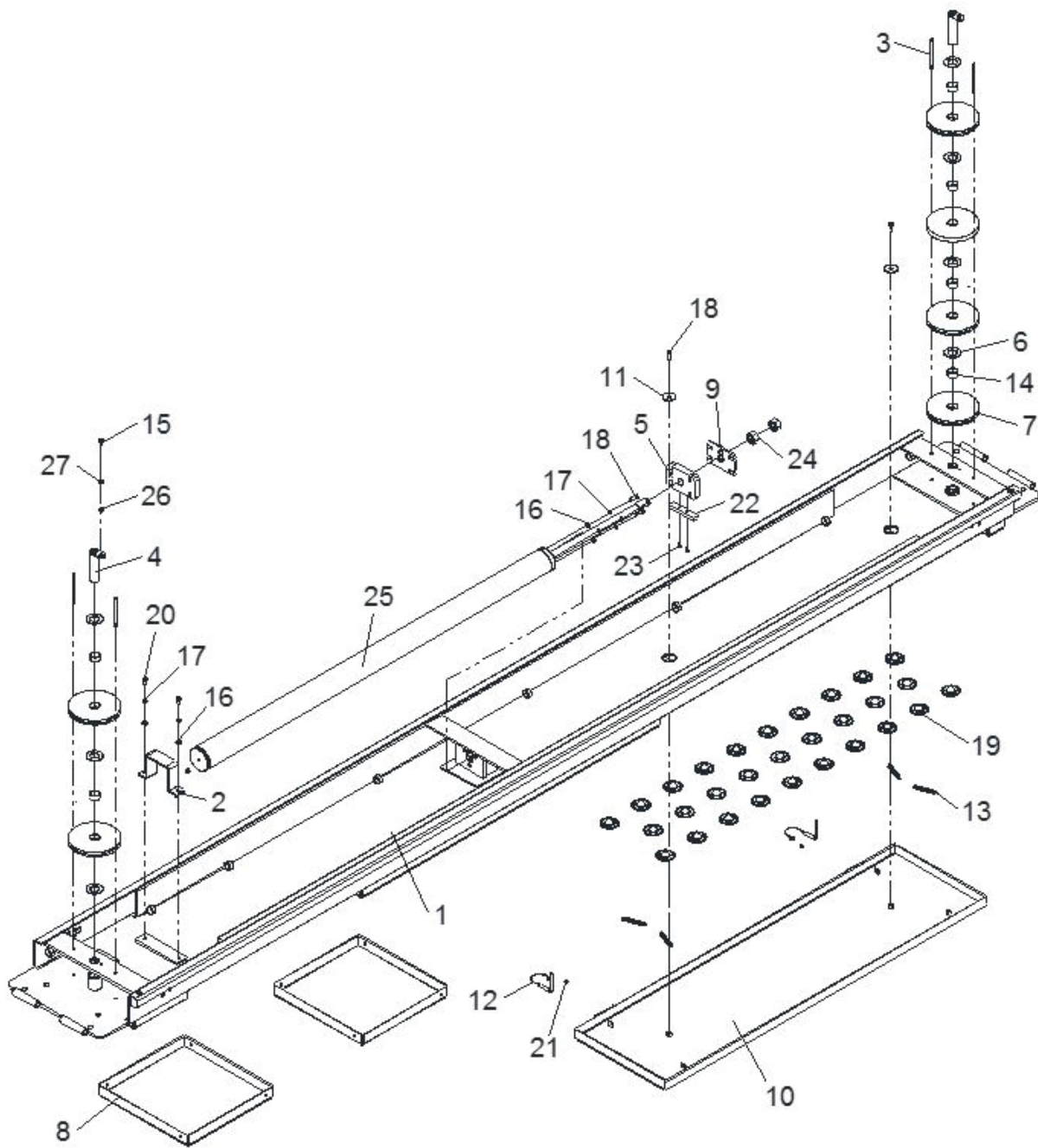

Power-Side Runway			
ITEM	PART NO.	DESCRIPTION	QTY
1	Z75A311000	Power-side platform	1
2	Z75A310008	Cylinder U plate	1
3	Z75A310009	Shaft	4
4	Z75A310100	Pulley shaft	2

Power-Side Runway			
ITEM	PART NO.	DESCRIPTION	QTY
5	Z75A310001	Cable holder	1
6	Z72E310003	Pulley spacer	7
7	Z72E310004	Cable pulley	6
8	Z72E310008	Turntable cover	2
9	Z72E310010	Cable retainer	1
10	Z72E310200	Slipping plate	1
11	Z72A300003	Washer	2
12	Z72A339000	Stop pin	2
13	Z71P211811	Spring	4
14	0210021	Bush 3520/SF-1	6
15	0201026	Screw M8X16 - GB/T5783	2
16	0205011	Washer D.10 - GB/T97.1	2
17	0208007	Locking washer D.10 - GB/T93	2
18	0201049	Screw M10X30 - GB/T5783	5
19	0215087	Steel ball bearing	29
20	0201062	Screw M10X20 - GB/T5783	2
21	0206036	Screw M6X8 - GB/T818	2
22	Z71P310016	Nylon slider	1
23	0202025	Screw M6X14 - GB/T70.1	2
24	0204011	Nut M27	2
25	Z75AY80000	Hydraulic cylinder	1
26	0205008	Washer D.8 - GB/T97.1	2
27	0208006	Locking Washer D.8 - GB/T93	2

Off-Side Runway

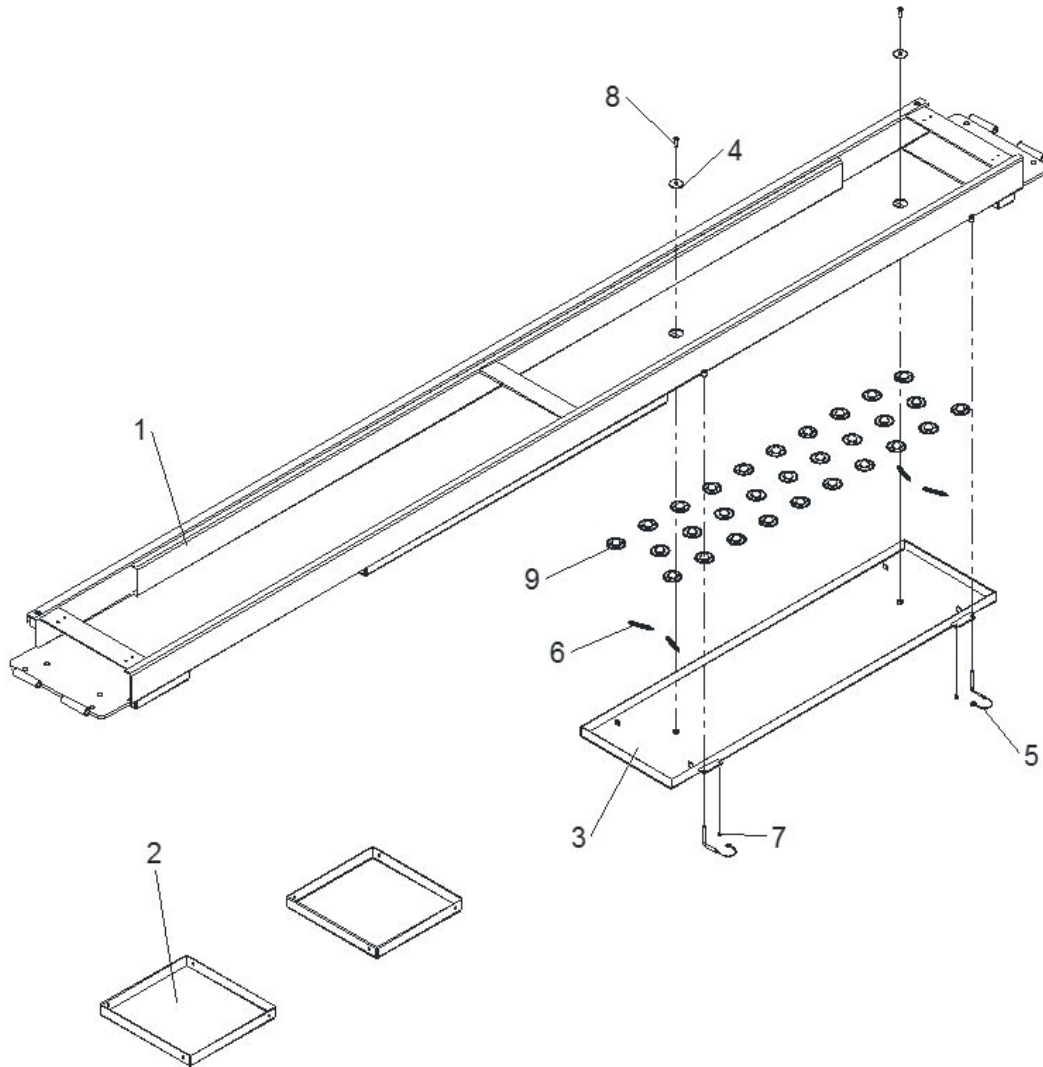

Off-Side Runway			
ITEM	PART NO.	DESCRIPTION	QTY
1	Z75A321000	Off-side platform	1
2	Z72E310008	Turntable cover	2
3	Z72E310200	Slipping plate	1
4	Z72A300003	Washer	2
5	Z72A339000	Stop pin	2
6	Z71P211811	Spring	4
7	0206036	Screw M6X8 - GB/T818	2
8	0201049	Screw M10X30 - GB/T5783	2
9	0215087	Steel ball bearing	29

Jacking Beam

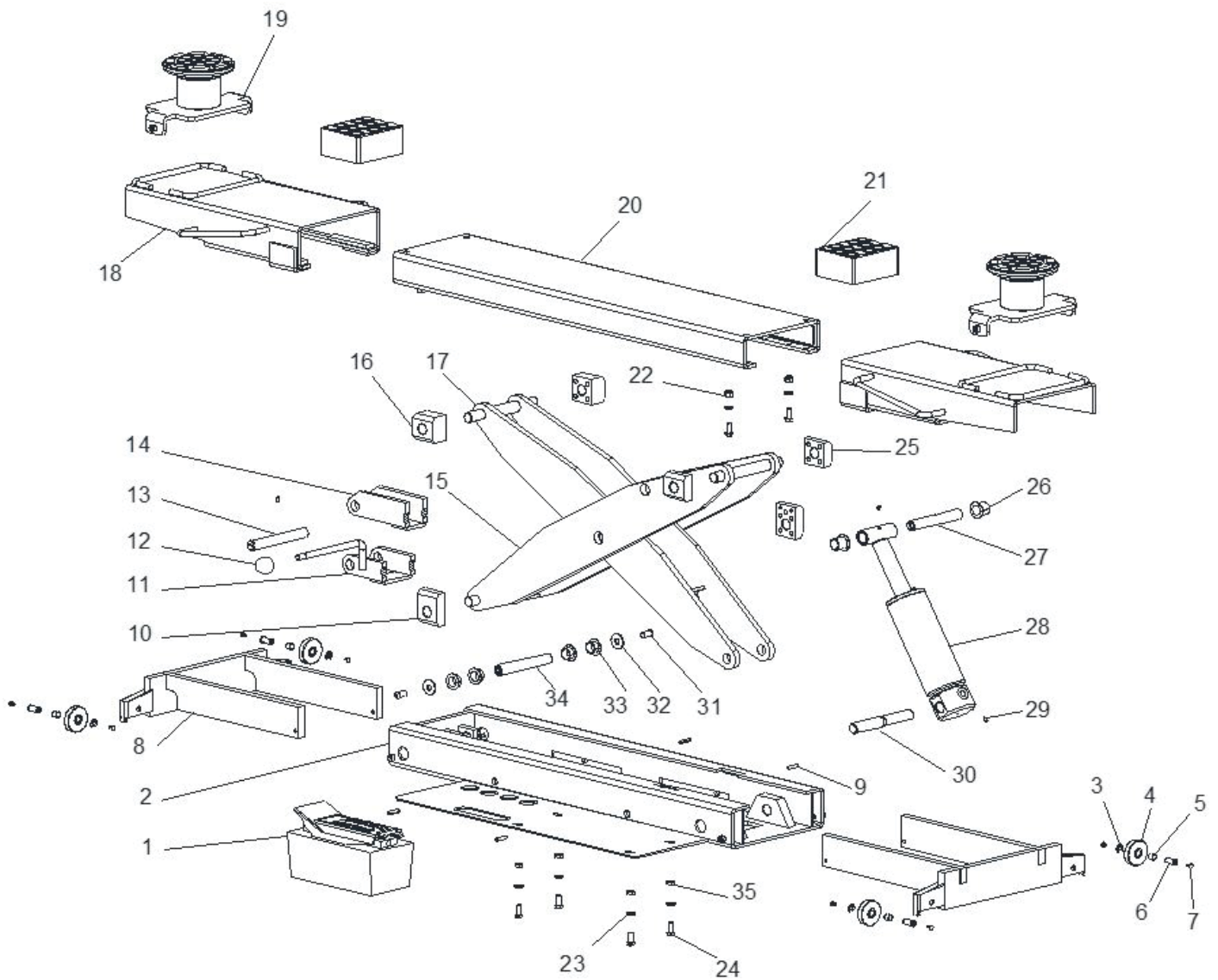

Jacking Beam			
ITEM	PART NO.	DESCRIPTION	QTY
1	0301052	Air-hydraulic pedal pump 800CC	1
2	J07B110000	Jack base	1
3	0211015	Seeger D.8 – GB/896	4
4	J07B100100	Jack wheel	4
5	0511172	Nylon bush 1010	4
6	J07B100001	Wheel shaft	4
7	0511173	Nylon pin	8
8	J07B120000	Base extension	2

Jacking Beam			
ITEM	PART NO.	DESCRIPTION	QTY
9	0213109	Elastic pin 6X25 – GB/T879.1	4
10	J07B000003	Nylon lower slider	2
11	J07B000200	Safety lock 2	1
12	0215017	Knob M10X33	1
13	J07B000005	Shaft	1
14	J07B000100	Safety lock 1	1
15	J07B200000	Outer scissor arm	1
16	J07B000001	Nylon upper slider 1	2
17	J07B300000	Inner scissor arm	1
18	J07B500000	Table extension	2
19	J07B600000	Screw adaptor	2
20	J07B400000	Jack table	1
21	0606033	Rubber pad 115X100X55	2
22	0204004	Nut M8 – GB/T889.1	2
23	0208003	Washer D.5 – GB/T93/5	4
24	0206041	Screw M5X12 – GB/T818	4
25	J07B000002	Nylon upper slider 2	2
26	0210089	Bush SF-1/2024F	2
27	J07B000007	Cylinder upper shaft	1
28	J07BY63000	Jack hydraulic cylinder	1
29	0209010	Screw M6X10 – GB/T78	3
30	J07B000006	Cylinder lower shaft	1
31	0206069	Screw M10X20 – GB/T70.2	2
32	J07B000008	Washer	2
33	0210086	Bush SF-1/2012F	4
34	J07B000004	Middle shaft	1
35	0205004	Washer D.5 – GB/ T97.1	4

Hydraulic Line

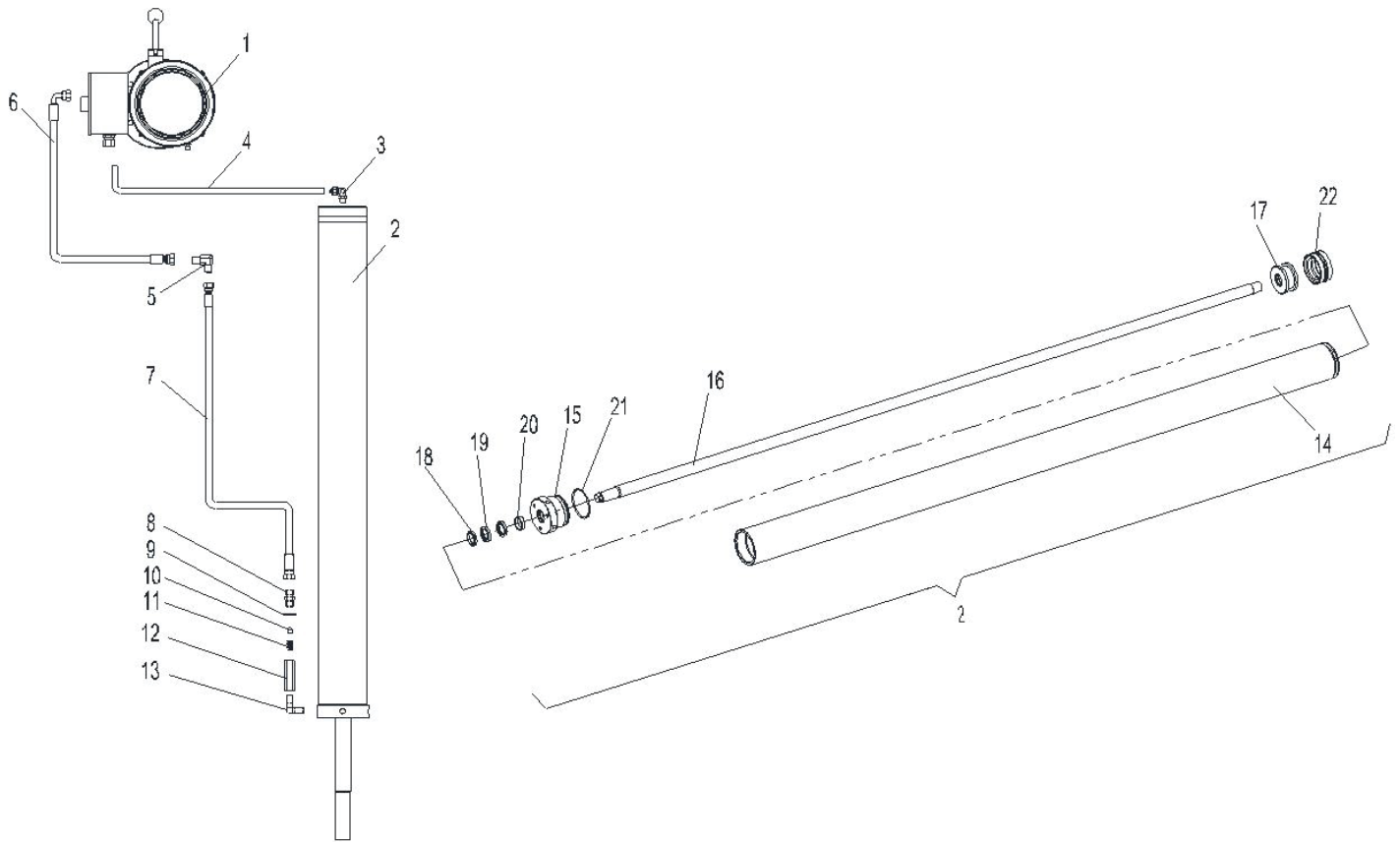

Hydraulic Line			
ITEM	PART NO.	DESCRIPTION	QTY
1	0302012	Hydraulic power unit	1
2	Z75AY80000	Hydraulic cylinder	1
3	0306065	Rotation union 8-1/4	1
4	0306096	PU hose 8X5.5X2500	1
5	0303010	90° union 1B9-04SP	1
6	ZW1600	Hydraulic pipe L=1600	1
7	ZZ1830	Hydraulic pipe L=1830	1
8	0303065	Fitting 1/4	1
9	0313001	Washer 1/4	1
10	6432-Y1.5	Flow restrictor	1
11	7530-Y-3	Spring	1
12	7B-04-87	Union	1
13	0303031	90° fitting 1/4	1

Hydraulic Line			
ITEM	PART NO.	DESCRIPTION	QTY
14	Z75AY80100	Cylinder liner	1
15	Z75AY80001	Cylinder guiding cover	1
16	Z75AY80002	Piston rod	1
17	Z75AY80003	Piston	1
18	0311005	Scraper 30X38X5/6.5	1
19	0310040	Seal 30X40X6	2
20	0305007	Guiding ring 30X10X2.5	1
21	0309139	O-ring 73X3.55	1
22	0312016	Gasket 80X60X22.4	1

Warranty



This item is warranted for five (5) years on structural components, two (2) years on hydraulic cylinders, and one (1) year on electric or air / hydraulic power units from invoice date. Wear items are covered by a 90 day warranty.

This LIMITED warranty policy does **not include a labor** warranty.

NOTE: ALL WARRANTY CLAIMS MUST BE PRE-APPROVED BY THE MANUFACTURER TO BE VALID.

The Manufacturer shall repair or replace at their option for this period those parts returned to the factory freight prepaid, which prove after inspection to be defective. This warranty will not apply unless the product is installed, used and maintained in accordance with the Manufacturers installation, operation and maintenance instructions.

This warranty applies to the ORIGINAL purchaser only, and is non-transferable. The warranty covers the products to be free of defects in material and workmanship but, does not cover normal maintenance or adjustments, damage or malfunction caused by: improper handling, installation, abuse, misuse, negligence, carelessness of operation or normal wear and tear. In addition, this warranty does not cover equipment when repairs or alterations have been made or attempted to the Manufacturer's products.

THIS WARRANTY IS EXCLUSIVE AND IS LIEU OF ALL OTHER WARRANTIES EXPRESSED OR IMPLIED INCLUDING ANY IMPLIED WARRANTY OR MERCHANTABILITY OR ANY IMPLIED WARRANTY OF FITNESS FROM A PARTICULAR PURPOSE, AND ALL SUCH IMPLIED WARRANTIES ARE EXPRESSLY EXCLUDED.

THE REMEDIES DESCRIBED ARE EXCLUSIVE AND IN NO EVENT SHALL THE MANUFACTURER, NOR ANY SALES AGENT OR OTHER COMPANY AFFILIATED WITH IT OR THEM, BE LIABLE FOR SPECIAL CONSEQUENTIAL OR INCIDENTAL DAMAGES FOR THE BREACH OF OR DELAY IN PERFORMANCE OF THIS WARRANTY. THIS INCLUDES, BUT IS NOT LIMITED TO, LOSS OF PROFIT, RENTAL OR SUBSTITUTE EQUIPMENT OR OTHER COMMERCIAL LOSS.

PRICES: Prices and specifications are subject to change without notice. All orders will be invoiced at prices prevailing at time of shipment. Prices do not include any local, state or federal taxes.

RETURNS: Products may not be returned without prior written approval from the Manufacturer.

DUE TO THE COMPETITIVENESS OF THE SELLING PRICE OF THESE LIFTS, THIS WARRANTY POLICY WILL BE STRICTLY ADMINISTERED AND ADHERED TO.