

# INSTALLATION & OPERATION MANUAL



## Atlas 12AWFSL 12,000 lb. Capacity Alignment Scissor Lift



**Atlas Automotive Equipment**  
[www.atlasautoequipment.com](http://www.atlasautoequipment.com)  
(866) 898-2604

Revised: 01/28/2020

**Read this entire manual before operation begins.**

Record below the following information which is located on the serial number data plate.

Serial No. \_\_\_\_\_

Model No. \_\_\_\_\_

Date of Installation \_\_\_\_\_





# ———— Contents ————

General Information . . . . .	5
Product Identification . . . . .	8
Packing, Transport, Storage . . . . .	10
Product Description . . . . .	12
Technical Specification. . . . .	14
Safety . . . . .	24
Installation . . . . .	28
Operation And Use . . . . .	39
Maintenance . . . . .	48
Troubleshooting. . . . .	50
Parts List . . . . .	53
Warranty . . . . .	81

---

## PRINTING CHARACTERS AND SYMBOLS

Throughout this manual, the following symbols and printing characters are used to facilitate reading:

	Indicates the operations which need proper care
	Indicates prohibition
	Indicates a possibility of danger for the operators
	Indicates the direction of access for motor vehicles to the lift
<b>BOLD TYPE</b>	Important information

	<b>WARNING: before operating the lift and carrying out any adjustments, read chapter 7 “installation” where all proper operations for a better functioning lift are shown.</b>
---	--

# General Information

---

This chapter contains warning instructions to operate the lift properly and prevent injury to operators or objects.

This manual has been written to be used by shop technicians in charge of the lift (operator) and routine maintenance technician (maintenance operator).

The operating instructions are considered to be an integral part of the machine and must remain with it for its whole useful life.

Read every section of this manual carefully before operating the lift and unpacking it since it gives helpful information about:

- **SAFETY OF PEOPLE**
- **SAFETY OF THE LIFT**
- **SAFETY OF LIFTED VEHICLES**

The company is not liable for possible problems, damage, accidents, etc. resulting from failure to follow the instructions contained in this manual.

Only skilled technicians of AUTHORIZED DEALERS or SERVICE CENTERS AUTHORIZED by the manufacturer shall be allowed to carry out lifting, transport, assembling, installation, adjustment, calibration, settings, extraordinary maintenance, repairs, overhauling and dismantling of the lift.

**THE MANUFACTURER IS NOT RESPONSIBLE FOR POSSIBLE DAMAGE TO PEOPLE, VEHICLES OR OBJECTS IF SAID OPERATIONS ARE CARRIED OUT BY UNAUTHORIZED PERSONNEL OR THE LIFT IS IMPROPERLY USED.**

Any use of the machine made by operators who are not familiar with the instructions and procedures contained herein shall be forbidden.

## 1.1 Manual Keeping

For a proper use of this manual, the following is recommended:

- Keep the manual near the lift, in an easily accessible place.
- Keep the manual in an area protected from the damp.
- Use this manual properly without damaging it.
- Any use of the machine made by operators who are not familiar with the instructions and procedures contained herein shall be forbidden.

This manual is an integral part of the lift: it shall be given to the new owner if and when the lift is resold.

## 1.2 Obligation In Case Of Malfunction



	<b>In case of machine malfunction, follow the instructions contained in the following chapters.</b>
---	---

## 1.3 Cautions For The Safety Of The Operator

Operators must not be under the influence of sedatives, drugs or alcohol when operating the machine.

	<b>Before operating the lift, operators must be familiar with the position and function of all controls, as well as with the machine features shown in the chapter "Operation and use".</b>
---	---

## 1.4 Warnings

	<b>Unauthorized changes and/or modifications to the machine relieve the manufacturer of any liability for possible damages to objects or people. Do not remove or make inoperative the safety devices, this would cause a violation of safety at work laws and regulations.</b>
	<b>Any other use which differs from that provided for by the manufacturer of the machine is strictly forbidden.</b>
	<b>The use of non genuine parts may cause damage to people or objects.</b>

## 1.5 Scrapping

When your machine's working life is over and it can no longer be used, it must be made inoperative by removing any connection to power sources. These units are considered as special waste material, and should be broken down into uniform parts and disposed of in compliance with current laws and regulations. If the packing are not polluting or non-biodegradable, deliver them to appropriate handling station.

### **DECLARATION OF WARRANTY AND LIMITATION OF LIABILITY**

The manufacturer has paid proper attention to the preparation of this manual. However, nothing contained herein modifies or alters, in any way, the terms and conditions of manufacturer agreement by which this lift was acquired, nor increase, in any way, manufacturer's liability to the customer.

### **TO THE READER**

Every effort has been made to ensure that the information contained in this manual is correct, complete and up-to date. The manufacturer is not liable for any mistakes made when drawing up this manual and reserves the right to make any changes due the development of the product, at any time.

# Product Identification

---

The identification data of the machine are shown in the label placed on the control unit.

LOGO	
Type:	.....
Model:	.....
Serial Number:	.....
Year of manufacturing:	.....
Capacity:	.....
Voltage:	.....
Power:	.....

	<b>Use the above data both to order spare parts and when getting in touch with the manufacturer (inquiry). The removal of this label is strictly forbidden.</b>
---	---

Machines may be updated or slightly modified from an aesthetic point of view and, as a consequence, they may present different features from those shown, this without prejudicing what has been described herein.

## 2.1 Warranty Certificate

The warranty is valid for a period of 12 months starting from the date of the purchase invoice. The warranty will come immediately to an end when unauthorized modifications to the machine or parts of it are carried out. The presence of defects in workmanship must be verified by the Manufacturer's personnel in charge.



## **2.2 Technical Servicing**

For all servicing and maintenance operations not specified or shown in these instructions, contact your Dealer where the machine has been bought or the Manufacturer's Commercial Department.

Only skilled personnel who are familiar with the lift and this manual shall be allowed to carry out packing, lifting, handling, transport and unpacking operations.

# Packing, Transport, Storage

---

## 3.1 Packing

The packing of the lift is delivered in following components:

- No. 2 base units, each one with a runway equipped with 2 hydraulic cylinders
- No. 1 jack beam with an air pedal pump
- No. 1 control unit and containing hydraulic unit, hydraulic hoses, air hoses, anchor bolts, rubber blocks and the technical files.
- No. 2 turntable recess covers
- No. 2 drive-on ramps, 2 drive-off ramps, and 4 hose protective covers if the lift is ordered for on-floor installation

(If requested, optional accessories are available to satisfy each customer's requirements).

## 3.2 Lifting And Handling

When loading/unloading or transporting the equipment to the site, be sure to use suitable loading (e.g. cranes, trucks) and hoisting means. Be sure also to hoist and transport the components securely so that they cannot drop, taking into consideration the package's size, weight and center of gravity and it's fragile parts.

In Figure 1 there are the correct indications for the lifting of the runways:



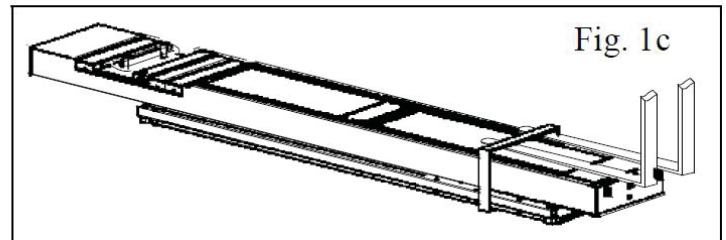
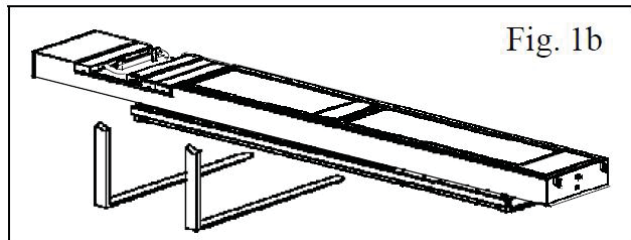
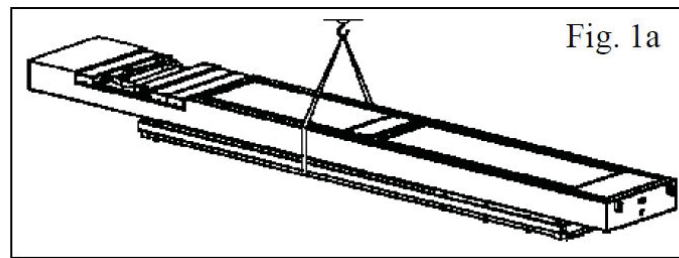

Figure 1 – Loading/Unloading Runway

### 3.3 Storage And Stacking Of Packages

Packages must be stored in a covered place, out of direct sunlight and in low humidity, at a temperature between 14°F and 104°F.

Stacking is not recommended: the package's narrow base, as well as its considerable weight and size make it difficult and hazardous.

### 3.4 Delivery And Check Of Packages

When the lift is delivered, check for possible damages due to transport and storage; verify that what is specified in the manufacturer's confirmation of order is included. In case of damage in transit, the customer must immediately inform the carrier of the problem.

Packages must be opened paying attention not to cause damage to people (keep a safe distance when opening straps) and parts of the lift (be careful the objects do not drop from the package when opening).

# Product Description

## 4.1 Lift Description (Ref. Figure 2)

This lift has been designed for the lifting of motor-vehicles for wheel alignment and maintenance. The lift can be mounted either on surface or in pit (flush mounted).

The maximum lifting weight is as specified on the serial plate.

All mechanical frames, such as platforms, extensions, base frames and arms have been built in steel plate to make the frame stiff and strong while keeping a low weight. The electro hydraulic operation is described in detail in chapter 8.

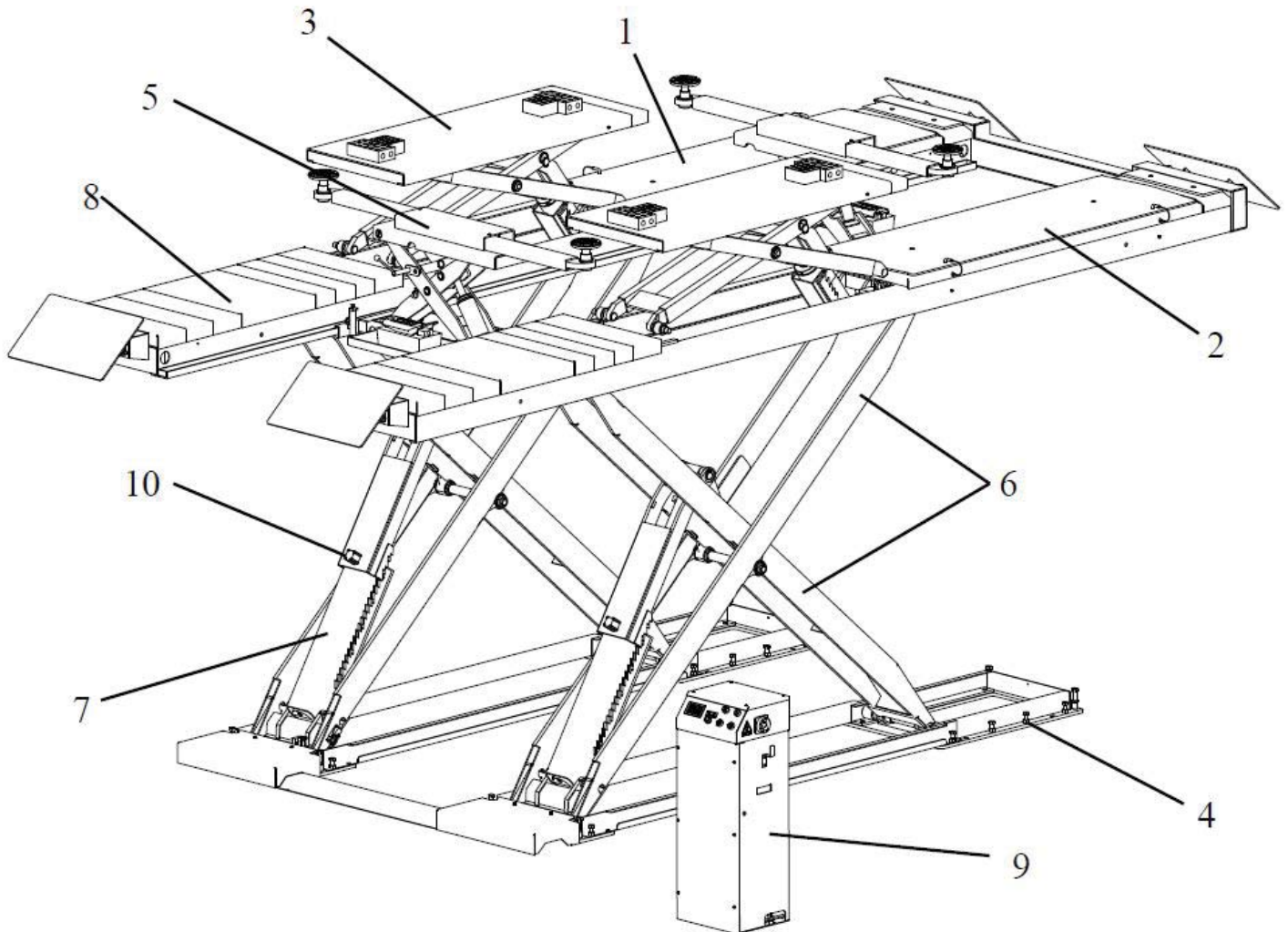

Figure 2 – Lift

This chapter describes the lift's principal elements, allowing the user to be familiar with the machine. As shown in figure 2, the lift is composed of two runways: P1(1) and P2 (2) with two wheel free jacks (3), anchored to the ground by means of its base (4). At a special request, two jack beam (5) can be supplied and operated by an air-hydraulic pedal pump.

Runways are linked to the base by means of a scissors lifting system. The lifting system of each runway is composed of scissor arms (6) and a hydraulic cylinder (7). Turntable recess cover (8) is supplied with the lift in case for non-alignment purpose. Lifting and lowering motion of lift and wheel free jacks is carried out by operation of a control unit (9) placed next to the lift.

The leveling system of the lift is carried out manually by operation of the leveling cocks in the power unit. The mechanical safety operating by a pneumatic cylinder (10) is built under each runway and wheel free jack for engagement and release. Two limit switches are installed in the P1 base: for top position limit and for the safety height limit.

## 4.2 Operation

Lift lifting is carried out by the hydraulic unit which acts upon the cylinders. The platforms are raised simultaneously owing cross feeding of the hydraulic cylinders. Lowering, even though electrically controlled, is carried out by the weight of both the platforms and the load lifted. Lowering motion of the wheel free jacks with load less can be sped up by means of pneumatic action in the chamber of its slave cylinder. The hydraulic system is protected by a max pressure valve thus preventing pressure from exceeding the maximum fixed safety limit.

Lifting and lowering motion of the lift is controlled by the push buttons on the control panel. The synchronization of the platforms is guaranteed by a master/ slave circuit. Whenever the lift has to be lowered to the ground and the lowering button is pressed, the lift will stop at about 18" from the ground. In this way, the operator must verify that neither persons nor objects are within the safety area. If so, the final lowering button can be pressed and the lift be lowered. A beep sound is heard during the last travel.

# Technical Specification

---

## 5.1 Size And Main Features (Ref. Figure 3)

<b>Capacity</b>	<b>12000 LBS (5000kg)</b>
Capacity of wheel free jacks	8800 lbs (4000kg)
Capacity of jacking beam	6000 lbs (2500kg)
Max. primary lifting height	85"
Max. secondary lifting height	17"
Jack beam lifting height with no extension	17"
Min. lowered height	11 1/2"
Length of the runway	196 7/8"
Adjusted length of the wheel free jack table	59" – 78 3/4"
Adjusted length of the jack beam arm	26 1/4" – 64"
Width of platform	24"
Suggested free width between runways	39 1/2"
Lifting time	70s
Lowering time	60s
Compressed air pressure	6 bar – 8 bar
Noise level	80 dB(A)/1m
Working temperature	14 °F - 104 °F
Package weight	5900 lbs including all

## 5.2 Electric Motor

<b>Type</b>	<b>ML90L2</b>
Voltage	220V-1Ph
Power	2.2 KW
N° Poles	2
Speed	2800 rpm
Motor enclosure type	B14
Insulation class	IP 54

Motor connection must be carried out referring to the attached wiring diagrams (Figure 6). The motor direction of rotation is shown in the label placed on the motor.

Before use of the lift, make sure to check if the motor specification shown in the nameplate of the motor conforms to the local electric supply.

If there is over 10% fluctuation on the electrical power supply, it is suggested to use the voltage stabilizer to protect the electrical components and system from overloading.

### 5.3 Pump

Type	Gear
Flow rate	1.3 cm <sup>3</sup> /g
Continuous working pressure	260 bar
Peak pressure	280 bar

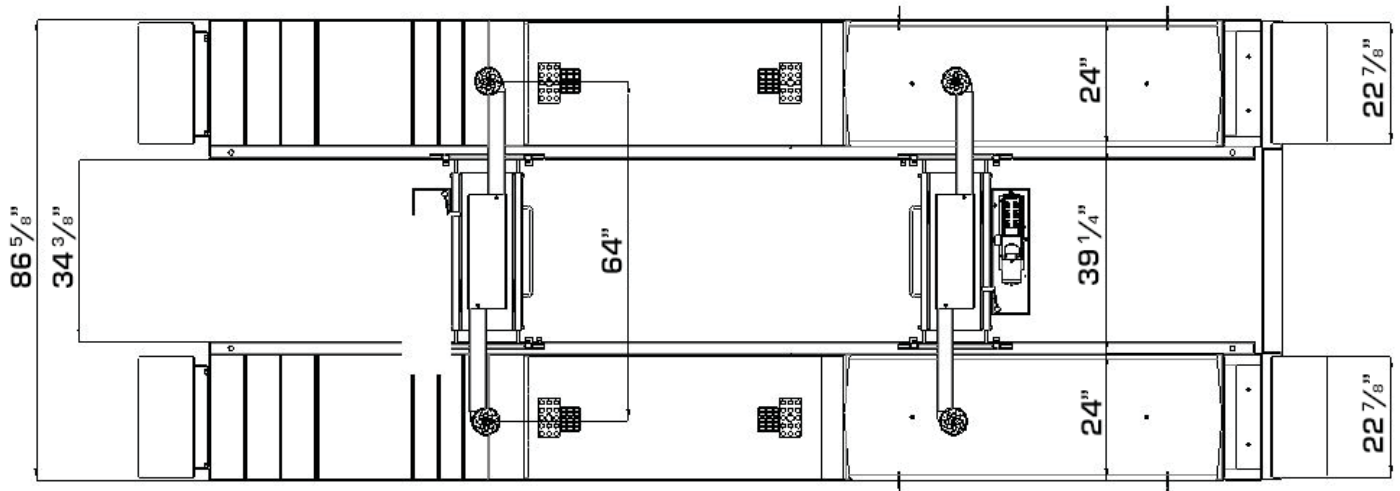
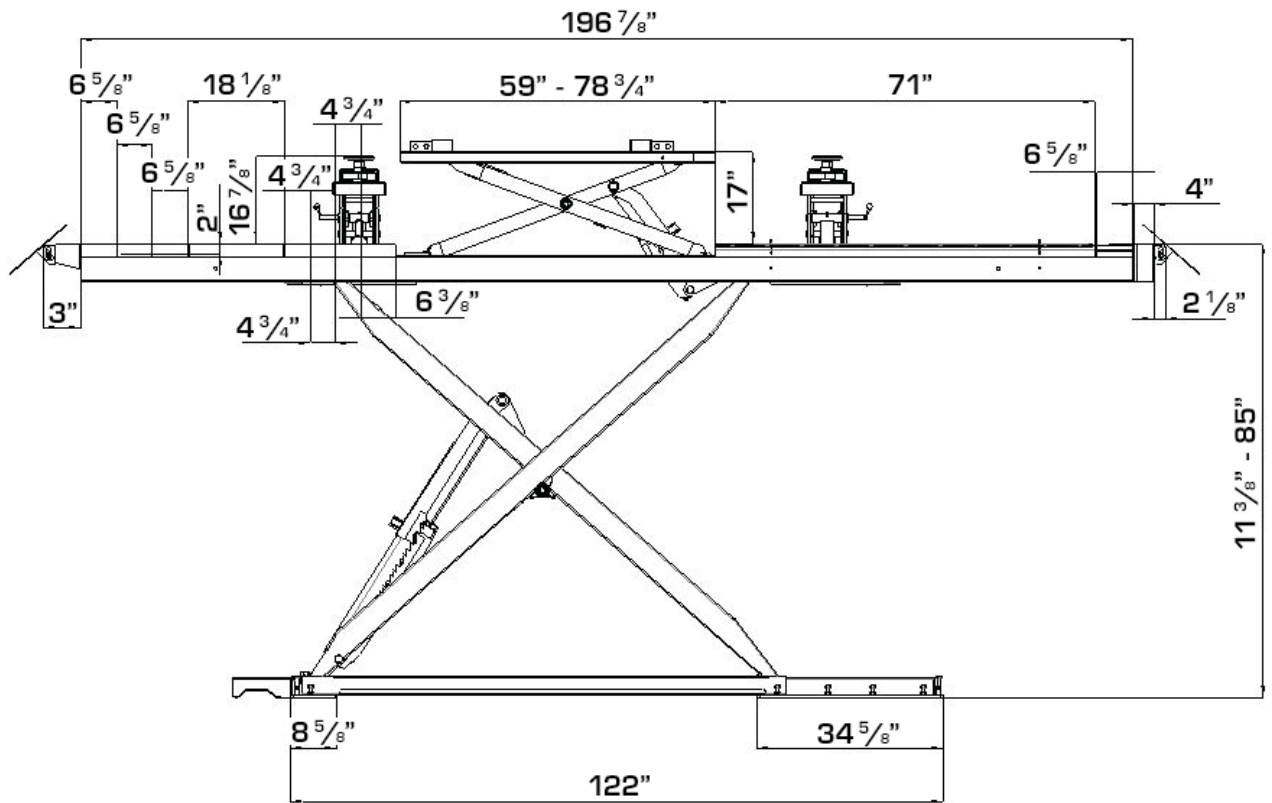

Figure 3A – Layout For In-Ground Installation



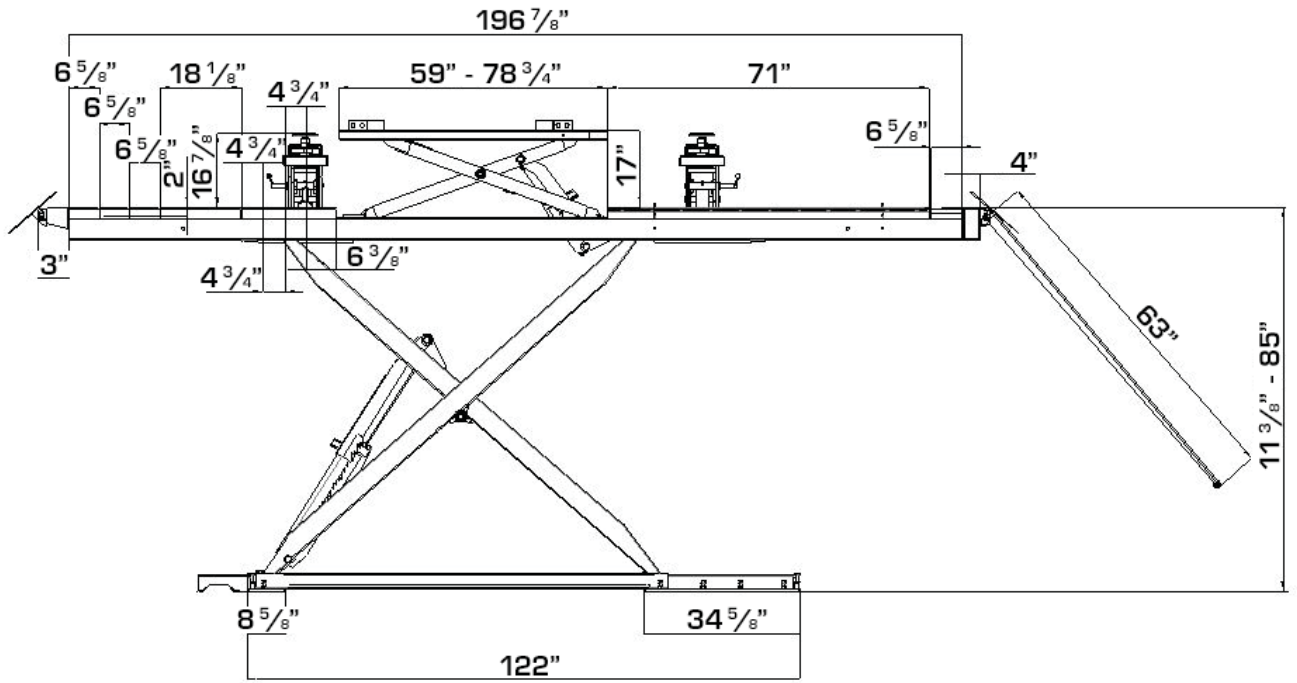

Figure 3B – Layout For On-Ground Installation

## 5.4 Hydraulic Unit

The hydraulic power unit is equipped with

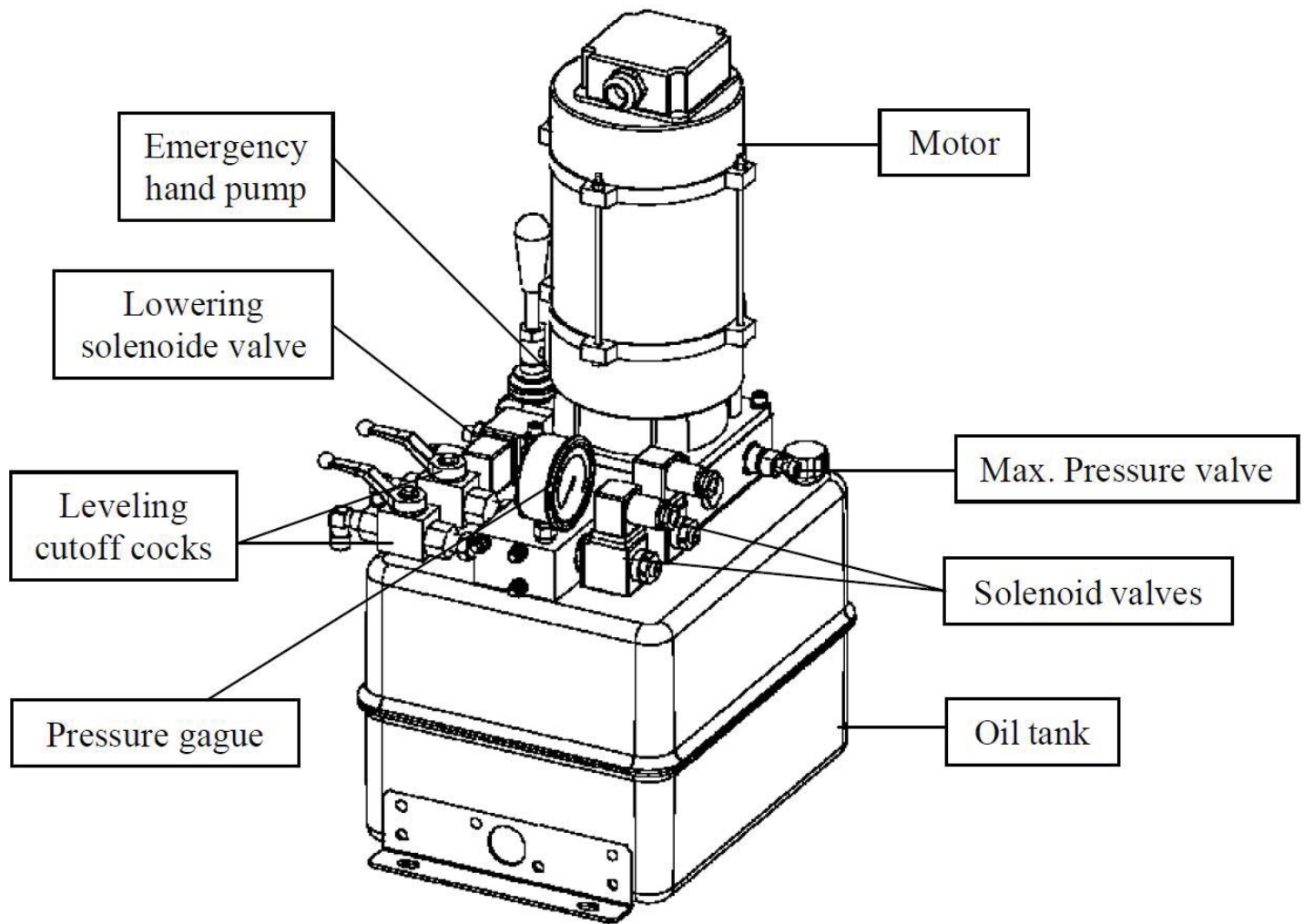

Figure 4 – Hydraulic Power Unit

## 5.5 Oil

Use wear proof oil for hydraulic drive, in conformity with *ISO 6743/4* rules (HM class). The oil with features similar to those shown in the table is recommended.

TEST STANDARDS	FEATURES	VALUE
ASTM D 1298	Density 20°C	0.8 kg/l
ASTM D 445	Viscosity 40°C	32 cSt
ASTM D 445	Viscosity 100°C	5.43 cSt
ASTM D 2270	Viscosity index	104 N°
ASTM D 97	Pour point	~ 30 °C
ASTM D 92	Flash point	215 °C
ASTM D 644	Neutralization number	0.5 mg KOH/g

	<b>CHANGE HYDRAULIC OIL AT 1 YEAR INTERVALS</b>
--	---

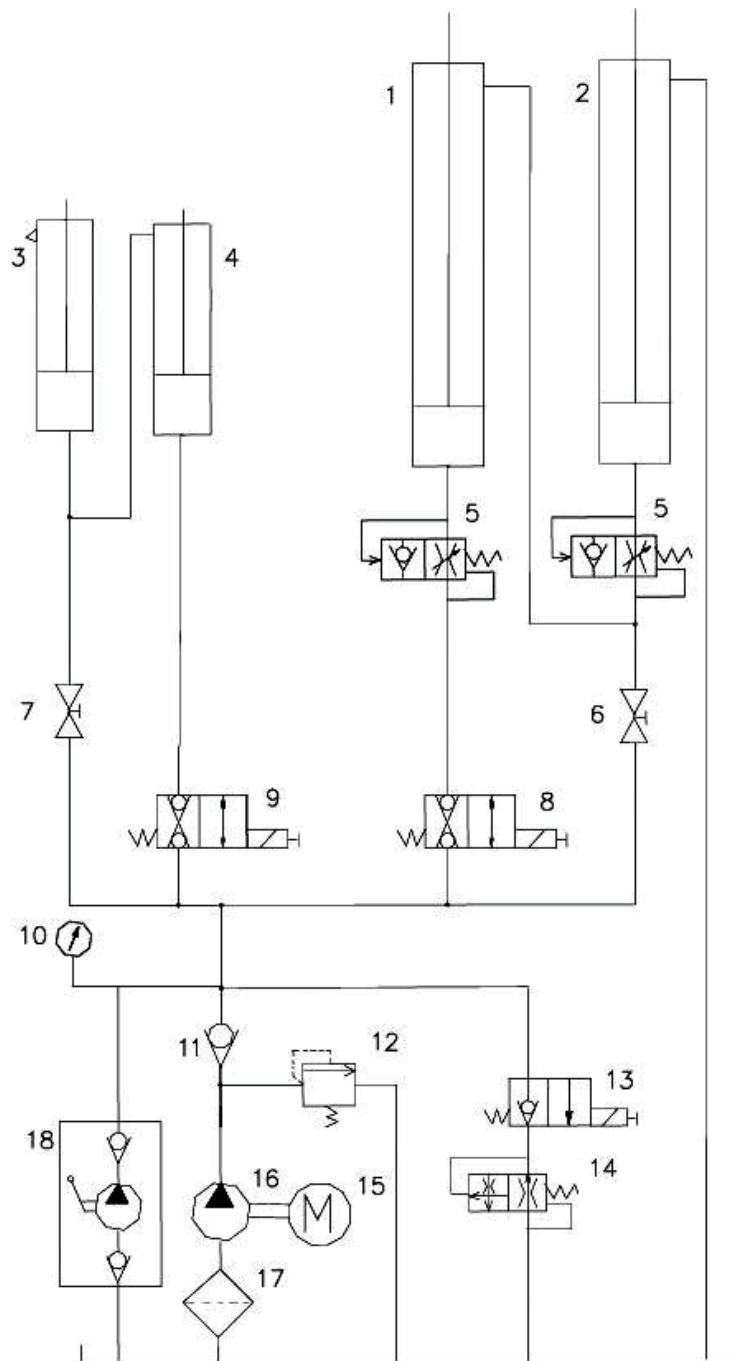

Figure 5 – Hydraulic Plan

1	Master runway cylinder P1	10	Pressure gauge
2	Slave runway cylinder P2	11	Non return valve
3	Master jack cylinder P2	12	Pressure overload valve
4	Slave jack cylinder P1	13	Lowering solenoid valve
5	Parachute valves (optional)	14	Lowering control valve
6	Leveling cutoff cock 1 - runways	15	Motor
7	Leveling cutoff cock 2 – jacks	16	Gear pump
8	Switching solenoid valve - runways	17	Oil filter
9	Switching solenoid valve – jacks	18	Emergency hand pump

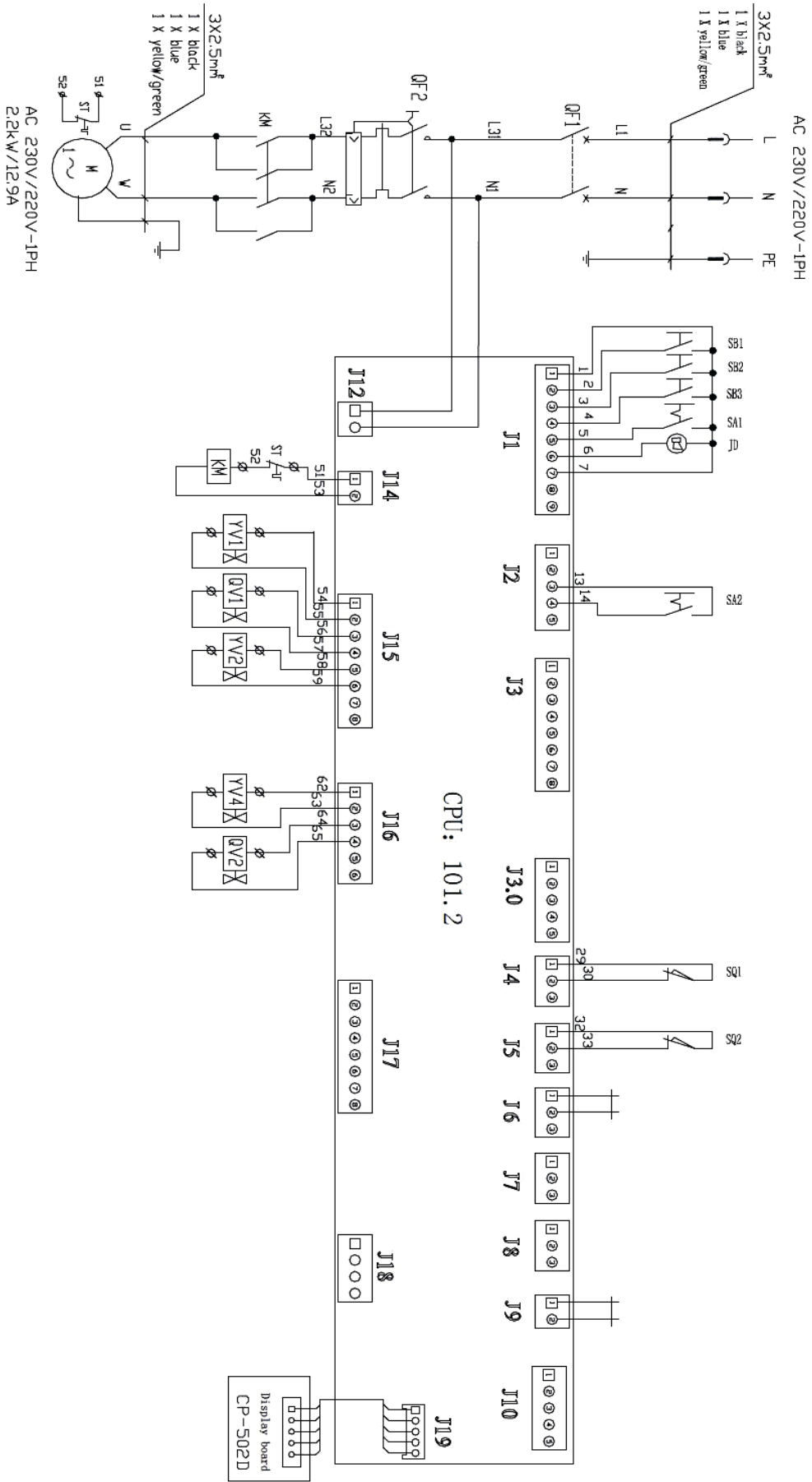

Figure 6 – Electrical Plan (220V- 1Ph)

QF1	Power switch
QF2	Breaker
M	Motor
ST	Thermal relay
KM	Contactora AC
SB1	Lifting button
SB2	Safety engaging button
SB3	Lowering/final lowering button
SA1	MAIN/JACK selector
SA2	WORK/ADJ selector
JD	Beeper
SQ1	Top limit switch
SQ2	Safety height limit switch
YV1	Lowering solenoid valve (220v)
YV2	Switching solenoid valve - runways (220v)
YV4	Switching solenoid valve - wheel free jacks (220v)
QV1	Safety air valve - runways (220v)
QV2	Safety air valve - wheel free jacks (220v)

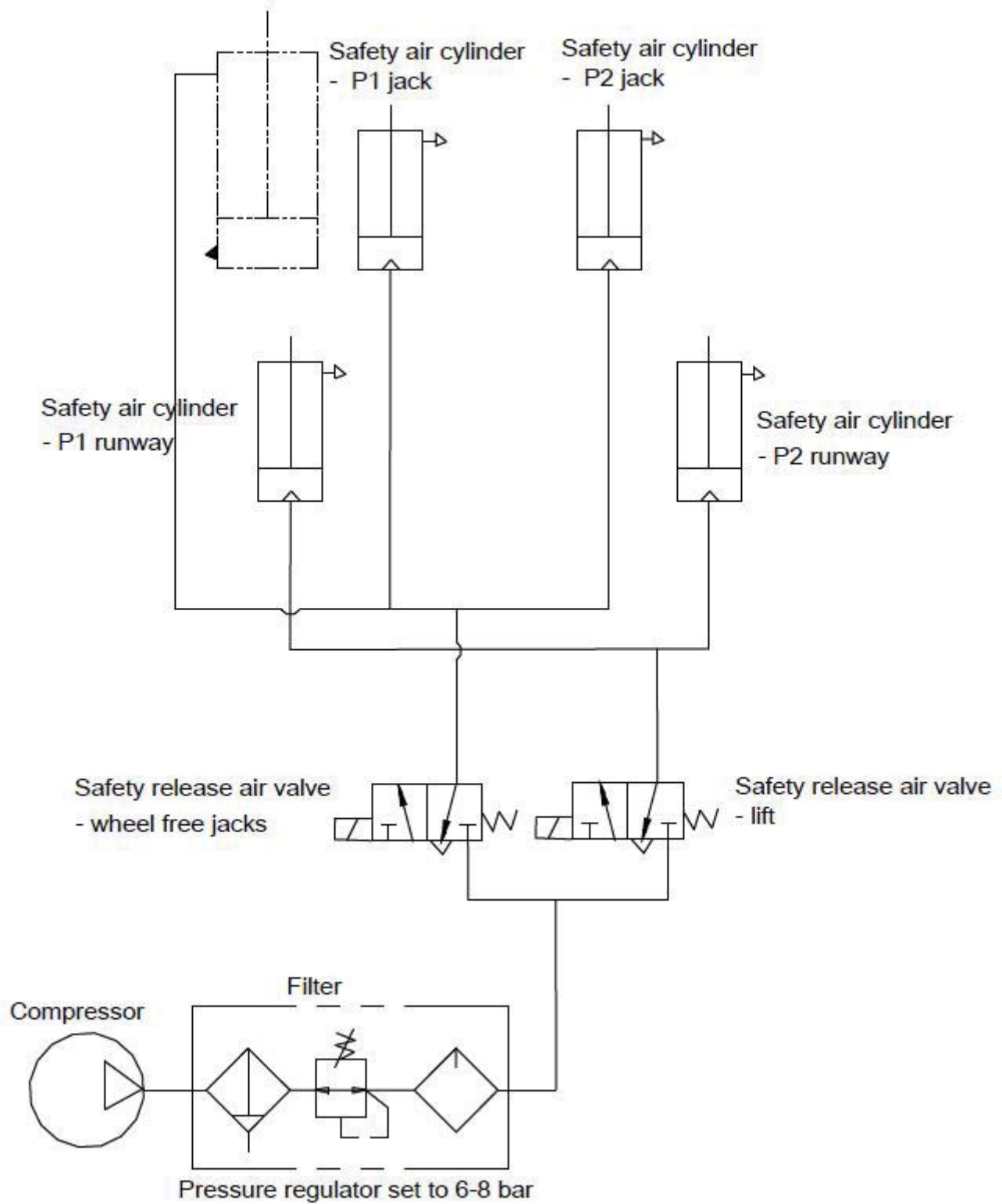



Fig. 7 - Pneumatic Plan

 **Filter/regulator is to be supplied by the customer if not order specially.**

# Safety

---

Read this chapter carefully and completely because it contains important information for the safety of the operator and the person in charge of maintenance.

	<p><b>The lift has been designed and built for lifting vehicles and making them stand above level in a closed area. Any other use is forbidden. The manufacturer is not liable for possible damages to people, vehicles or objects resulting from an improper or unauthorized use of the lift.</b></p>
---	--

For operator and people safety, the safety area shown in Figure 8 must be vacated during lifting and lowering. The lift must be operated only from the operator's control site, as shown.

Operator's presence under the vehicle, during working, is only admitted when the vehicle is lifted and platforms are not running

	<p><b>Never use the lift when safety devices are off-line. People, the lift and the vehicles lifted can be seriously damaged if these instructions are not followed.</b></p>
---	--

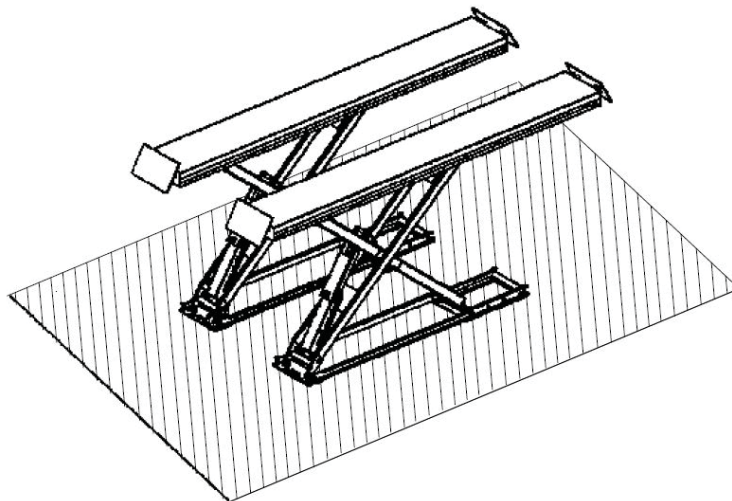

Figure 8 - Safety Area (Min. 3 Feet)



## 6.1 General Warnings

The operator and the person in charge of maintenance must follow accident-prevention laws and rules in force in the country where the lift is installed.

They also must carry out the following:

- Neither remove nor disconnect hydraulic, electric or other safety devices;
- Carefully follow the safety indications applied on the machine and included in the manual;
- Observe the safety area during lifting;
- Be sure the motor of the vehicle is off, the gear engaged and the parking brake put on;
- Be sure only authorized vehicles are lifted without exceeding the maximum lifting capacity;
- Verify that no one is on the platforms during lifting or standing.

## 6.2 Risks For People

All risks the personnel could run, due to an improper use of the lift, are described in this section.

## 6.3 Personnel Crushing Risks

During lowering of runways and vehicles, personnel must not be within the area covered by the lowering trajectory. The operator must be sure no one is in danger before operating the lift.

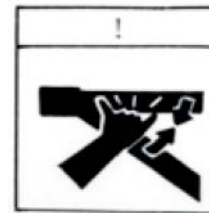
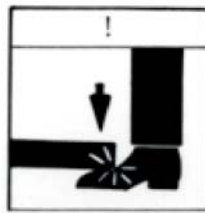

## 6.4 Bumping Risk

When the lift is stopped at relatively low height for working, the risk of bumping against projecting parts occurs.



## 6.5 Risk Of The Vehicle Falling From The Lift

Vehicle falling from the lift can be caused when the vehicle is improperly placed on platforms, and when its dimensions are incompatible with the lift or by excessive movement of the vehicle.

In this case, keep immediately away from the working area.

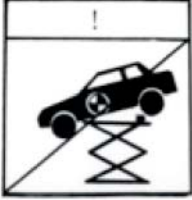

## 6.6 Slipping Risks

The risk of slipping can be caused by oil or dirt on the floor near the lift.



**Keep the area under and around the lift clean. Remove all oil spills.**

## 6.7 Electrocutation Risks

Avoid use of water, steam, and solvent, varnish jets in the lift area where electric cables are placed and, in particular, next to the electric panel.

## 6.8 Risks Resulting From Improper Lighting

Make sure all areas next to the lift are well and uniformly lit, according to local regulations.

## 6.9 Risks Of Breaking Component During Operation

Materials and procedures, suitable for the designed parameters of the lift, have been used by the manufacturer to build a safe and reliable product. Operate the lift only for the use it has been designed for and follow the maintenance schedule shown in the chapter "Maintenance".



## 6.10 Risks For Unauthorized Uses

The presence of unauthorized persons next to the lift and on the platforms is strictly forbidden during lifting as well as when the vehicle has been already lifted.



**Any use of the lift other than that herein specified can cause serious accidents to people in close proximity of the machine.**

## 6.11 Risks During Vehicle Lifting

To avoid overloading and possible breaking, the following safety devices have been used:

- A maximum pressure valve placed inside the hydraulic unit to prevent excessive weight.
- A special design of the hydraulic system, in case of pipeline failure, to prevent sudden lift lowering.



**The maximum pressure valve has been preset by the manufacturer to a proper pressure. DO NOT try to adjust it to overrun the rated lifting capacity.**

# Installation

---



**Only skilled technicians must be allowed to carry out installation. Serious damage to people and to the lift can be caused if installations are made by unskilled personnel.**

## 7.1 Checking For Room Suitability

The lift has been designed to be used in covered and sheltered places free of overhead obstructions. The place of installation must not be next to washing areas, painting workbenches, solvent or varnish deposits. The installation near to rooms, where a dangerous situation of explosion can occur, is strictly forbidden. The relevant standards of the local Health and Safety at Work regulations, for instance, with respect to minimum distance to wall or other equipment, escapes and the like, must be observed.

## 7.2 Lighting

Lighting must be carried out according to the effective regulations of the place of installation. All areas next to the lift must be well and uniformly lit.

## 7.3 Installation Foundation

The lift must be placed on a 425 concrete floor with FEB 215 K reinforcement, 15cm thick at least, and in conformity with local regulations. If a floor covering with the above mentioned requirements is not available, a foundation plate is needed or, some fixing points should be used, for fixing areas at least, having sufficient size and thickness (made of concrete of the same quality, as shown).

The surface where the lift has to be installed must be even and leveled in all directions. An inclination not higher than 2 cm in drive-on lift direction and 1 cm cross-wise can be balanced with leveling wedges. If an installation is made in a hole, the real side of the hole must be verified (as per drawing sent at the order). For installation on raised surface, the compliance with the maximum carrying capacity of the surface is recommended.

Floor fixing is the same both in on-floor and in-ground installations. The new concrete must be adequately cured by at least 21 days minimum.

## 7.4 Lift Positioning



**Unauthorized persons are not allowed to enter during assembly.**

- Transport each platform lifting system to the location or the recessed pit using hoisting device with a load capacity of *1.6 tons* at least. To prevent the platform from dropping during transport, it should be lifted according to its center of gravity.
- Place the control unit in the position provided for (the control unit can be place in either right side or left side).

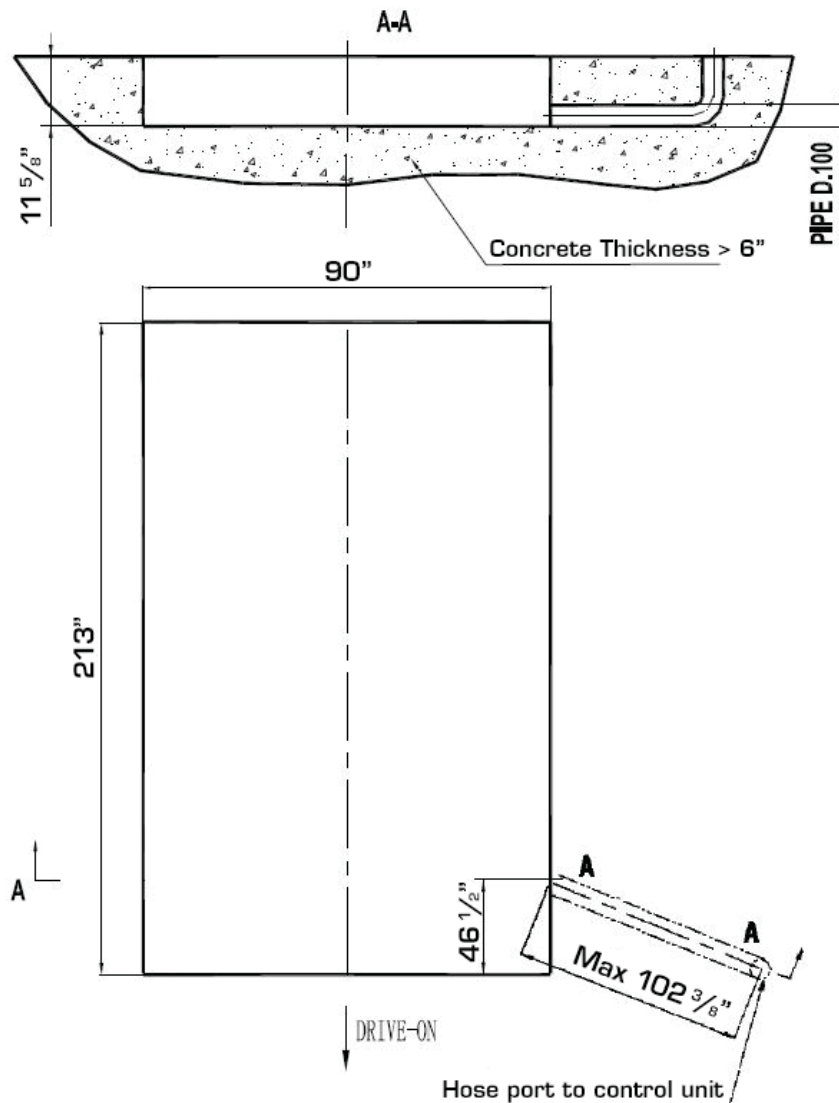



Figure 15 – Foundation Pit Plan (Only For Flush Mounted, With The Jack Beam)

## 7.5 Hydraulic System Connection

- Place runways and jack beams at the half way with auxiliary equipment by using strong ropes, bands or chains. Be sure the runways rests on the safeties before proceeding;
- Open the front cover of the control unit;
- Following to the Figure 16 route hydraulic lines referring to the letters shown on them through the pipe in the prepared foundation;
- Connect hydraulic hoses to the fittings;
- Tighten thoroughly.

 **When routing the hydraulic hoses, make sure that the hose is clear of any moving part, make sure to keep the hoses and fittings clean from dust. Failure to do so may result in hydraulic line failure which may result in damage or personal harm.**

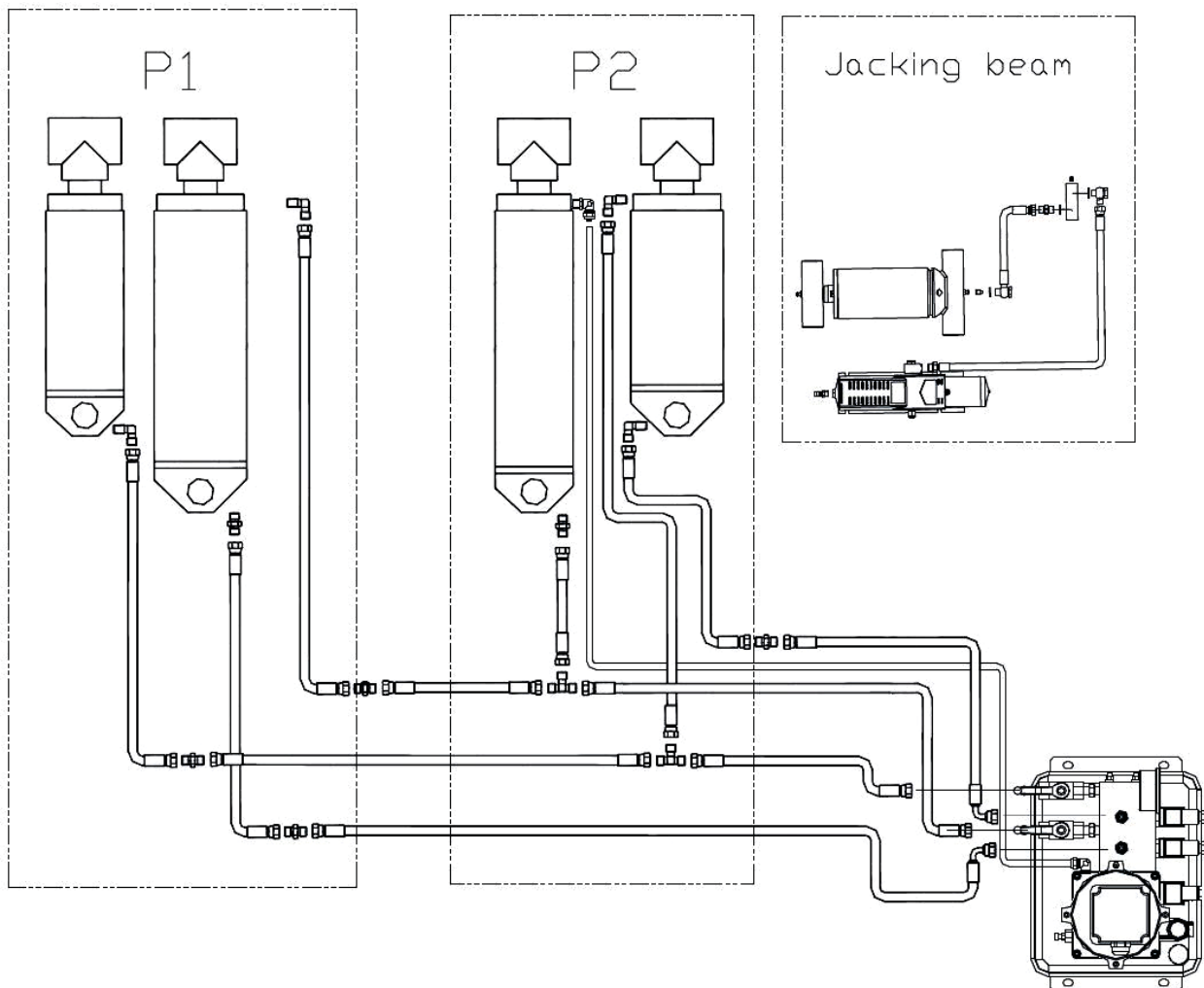

Figure 16 – Hydraulic Connections



When routing the hydraulic hoses, make sure that the hoses must be clear of any moving part. Make sure to keep the hoses clean from dust.

## 7.6 Pneumatic System Connection

The pneumatic supply at site (to which the pneumatic system of the lift is connected) must be equipped with a servicing unit composed of filter, lubricator and regulator.

For the connection of the pneumatic lines proceed as follow:

- Connect the pneumatic lines pre-assembled on the runways to the control unit referring to the Figure 17;
- Connect the pneumatic system of the lift to the pneumatic supply at site;
- Check the pneumatic control operations for proper performance.

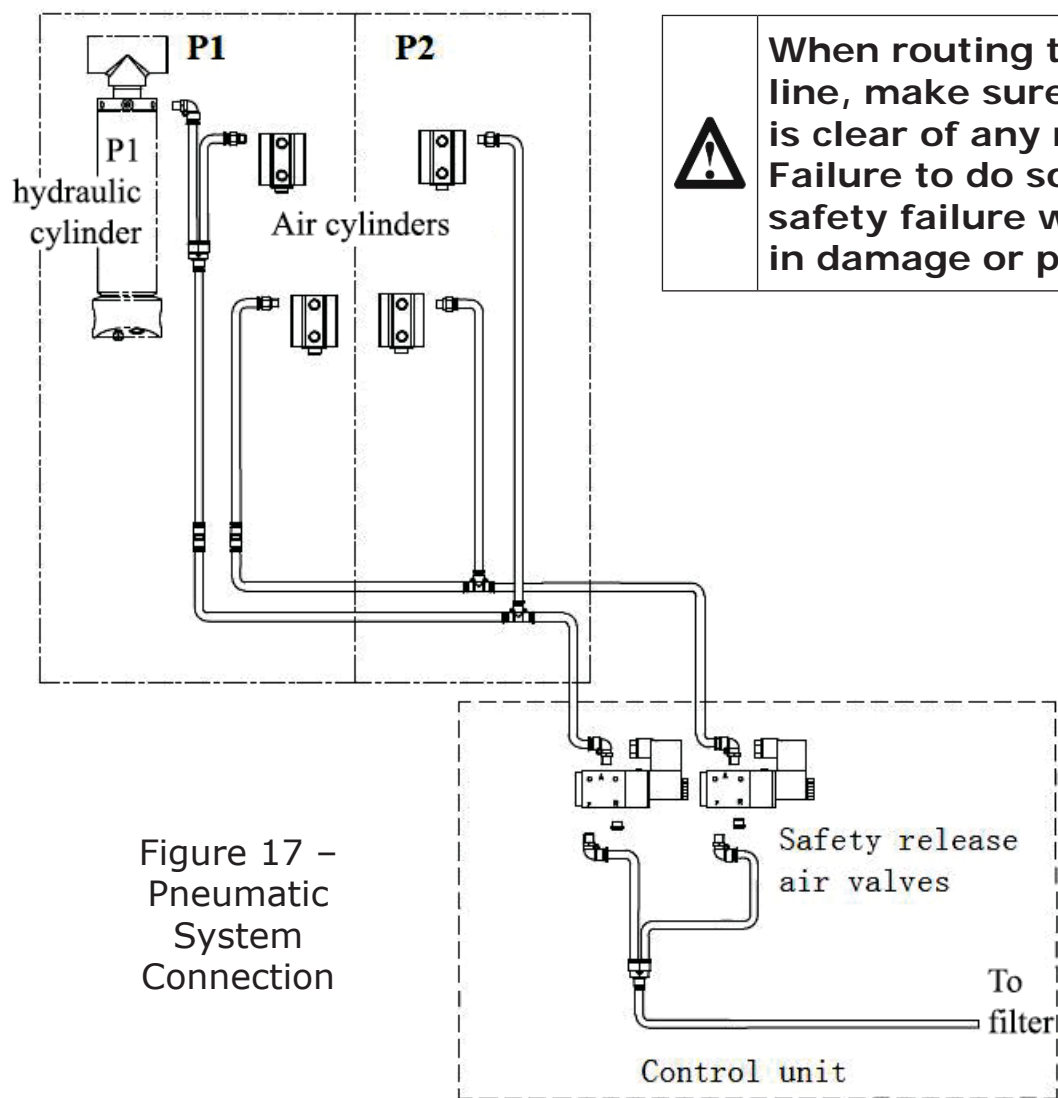

Figure 17 –  
Pneumatic  
System  
Connection



When routing the pneumatic line, make sure that the tube is clear of any moving part. Failure to do so may result in safety failure which may result in damage or personal harm.

## 7.7 Make The Electrical Hookup To Hydraulic Unit



The hookup work must be carried out by a qualified electrician. Make sure that the power supply is right. Make sure the connection of the phases is right. Improper electrical hook-up can damage motor and will not be covered under warranty. **DO NOT** run the hydraulic unit with no oil. Damage to pump can occur. The control unit must be kept dry.

- Make the electric hookup to the hydraulic power unit referring to the attached wiring diagram (Figure 6) using the included cables;
- Make sure the connection of the phases is right and the lift is grounded.

## 7.8 Feeding Oil And Bleeding Runways



Do not install the top limit switch before bleeding the hydraulic line. During this procedure, **DO NOT** attempt to raise lift with any load.

### 7.8.1 Start

- Double check all nuts, bolts etc. for tightness. **Even the pre-installed components.**
- Make sure the electrical system feeding voltage is equal to that specified in the nameplate on the motor;
- Make sure the electric connections are in compliant with diagrams (Figure 6);
- Make sure no leakage or blow-up in hydraulic line and pneumatic line;
- Make sure the lift is grounded;
- Make sure the working area is free from people and objects;
- Grease sliding all pivot pins;
- Pour oil in the tank (*3.5 to 5 Gallons of AW32 - AW46 Hydraulic Oil*);
- Verify that the control unit is powered by turning on the power switch;

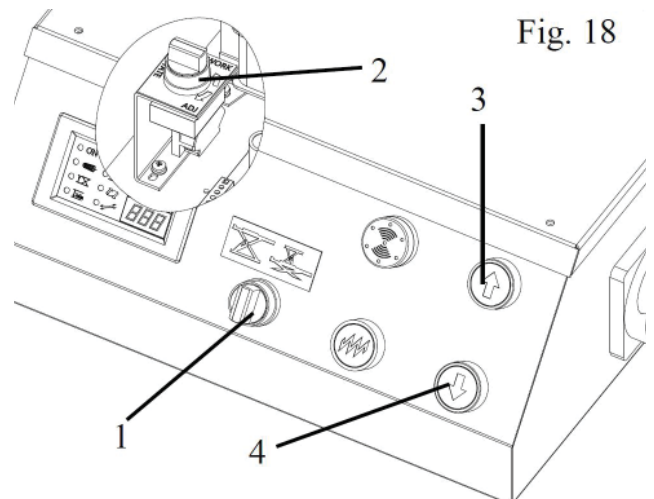

Fig. 18





- Set MAIN/JACK selector into the position “”;
- Open the top cover of the control unit, set ADJ/WORK selector into the position “WORK” (ref. Fig. 18);
- Open the front cover of the control unit, turn off both leveling cocks placed on the hydraulic unit (ref. Fig. 19);
- Verify that the motor direction of rotation is that shown on the motor arrow label by pushing the lifting button. IF MOTOR GETS HOT OR SOUNDS PECULIAR, STOP IMMEDIATELY AND RECHECK THE ELECTRIC CONNECTIONS;

Fig. 19

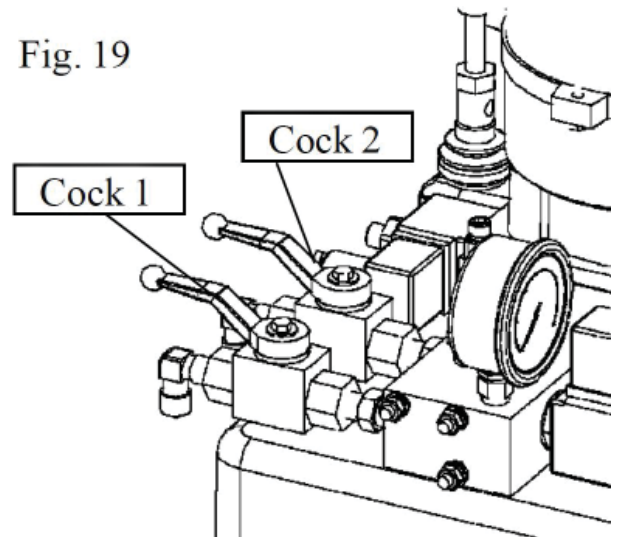

## 7.8.2 Feeding Oil And Bleeding - Runways

	<p><b>Pay much attention: refill the oil if not enough during this procedure. After bleeding, make sure to reset ordinary operating conditions. Lift cannot work properly if a leveling cutoff cock is opened.</b></p>
--	--

- Be sure ADJ/WORK selector is into the position “WORK”;
- Press the lifting button, the runway P1 (the master runway: the left side from the view toward the vehicle head) will be raised only;
- Keep pressing the lifting button to raise the runway P1 until it reaches the maximum height;
- Press the lowering button to lower the runway P1 completely;
- Raise the runway P1 again until it reaches the maximum height;
- Set ADJ/WORK selector into the position “ADJ”;
- Turn on the leveling cutoff cock 1;
- Press the lifting button to raise the runway P2 (the slave runway: the right side from the view toward the vehicle head) until the platform reaches the maximum height. Pay attention to refill the oil if not enough;
- Press the lowering button to lower the runway P2 completely;
- Repeat raise and lower the runway P2 completely at least 5 times;
- Raise the runway P2 to the same height as the runway P1;
- Turn off the leveling cutoff cock 1;

- Set ADJ/WORK selector into the position "WORK";
- Lower and raise the runways at least 3 times to check the level of runways. If not leveled, repeat above procedure.

### 7.8.3 Feeding Oil And Bleeding – Wheel Free Jacks

- Set MAIN/JACK selector into the position "";
- Be sure ADJ/WORK selector is into the position "WORK";
- Turn off both leveling cocks;
- Press the lifting button: the jack P2 (the master jack on the runway P2) will be raised;
- Keep pressing the lifting button to raise the jack P2 until it reaches the maximum height;
- Keep pressing the lowering button to lower the jack P2 completely;
- Raise the jack P2 again until it reaches the maximum height;
- Set ADJ/WORK switch into the position "ADJ"
- Turn on the leveling cutoff cock 2;
- Press the lifting button to raise the jack P1 (the slave jack on the runway P1) until it reaches the maximum height;
- Keep pressing the lowering button to lower the jack P1 completely;
- Repeat raise and lower the jack P1 completely at least 5 times;
- Raise the jack P1 to the same height as the jack P2;
- Turn off the leveling cutoff cock 2;
- Set ADJ/WORK selector into the position "WORK" after bleeding;
- Lower and raise both jacks at least 3 times to check the level. If not leveled, repeat above procedure.

If two jacks are not in the same level after above bleeding procedure, it's possible to level them by bleeding the jack P1 (the slave jack on the runway P1) in the following way:

- Place the jack P1 at approximate .4" height (make the cylinder stroke at approximate 2")
- Loosen the bleeding plug (ref. Fig.20) on the cylinder to let trapped air escape
- Re-tighten the plug after trapped air is escaped.

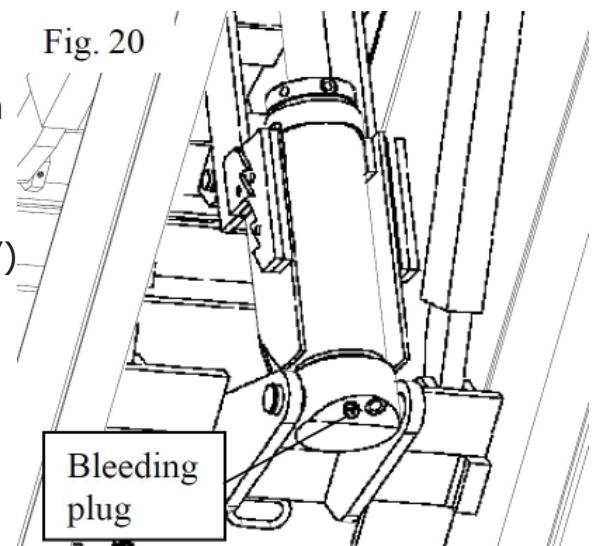

 **After bleeding of the lift, make sure to close all leveling cocks. Lift cannot be lifted if leveling cocks are opened.**

## 7.9 Anchoring And Runway Adjustment

To make an alignment of motor-vehicle, two runways should be perfectly leveled and be in the same height when resting on safeties.

For the proper adjustment of leveling accuracy proceed as follows:

- Raise the runways (without the vehicle) up to a height of about 3 feet (normal height for wheel alignment). Make sure two runways are in the same position when resting the safeties.
- Using the bases as guide, drill each hole in the concrete approximately 5 inches deep with the rotary hammer drill 16mm To assure full holding power, do not ream the hole or allow drill to wobble.
- After drilling, remove dust thoroughly from each hole using compressed air or wire brush.
- Assemble the washers and nuts on the anchors then tap into each hole with a hammer until the washer rests against the bases.

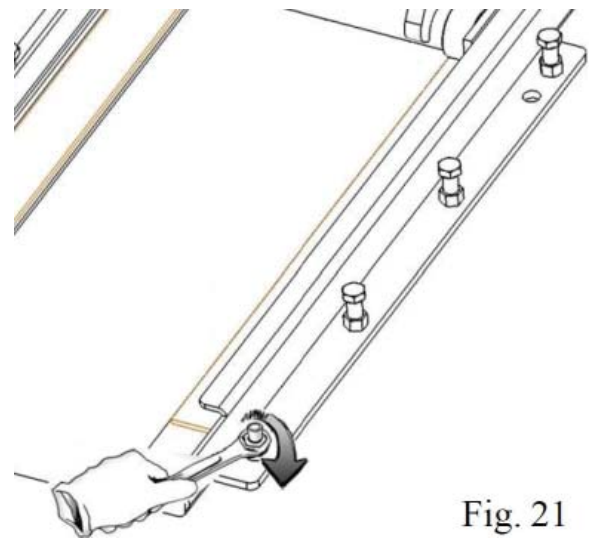

Fig. 21

- Verify that both the runways are leveled horizontally by means of a water gauge or an air bubble and, if necessary, adjust in the following way until the required conditions obtained:
  - unscrew four screws (1/fig.22) on the bracket on front of scissor arm;
  - Adjust two screws (2/fig.22) up or down until two platforms are leveled perfectly;
  - Once the required conditions have been obtained, insert the shims on top of bracket as shown in the figure 22;
- With the shims and the supplied anchor bolts in place, tighten by securing the nuts.

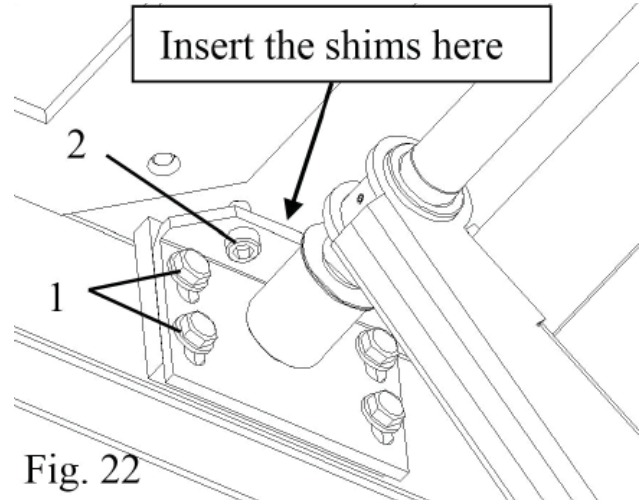



Fig. 22

## 7.10 Installation Of Limit Switches (Ref. Fig. 23)

	<p><b>Only skilled personnel must be allowed to carry out this operation. An improper adjustment of limit switches could cause damages to the lift, objects and people.</b></p>
--	---

### 7.10.1 Max. Height Limit Switch

- Place the lift at a height of 85 inches;
- Mount the switch (1) on the bracket;
- Raise it at a height of 85 inches to check the limit switch for proper installation;
- If the switch was not functioning properly, it's possible to adjust it by screwing the nuts of switch;
- Tighten the nuts after adjustment.
- Fix the switch cover with the supplied screws.

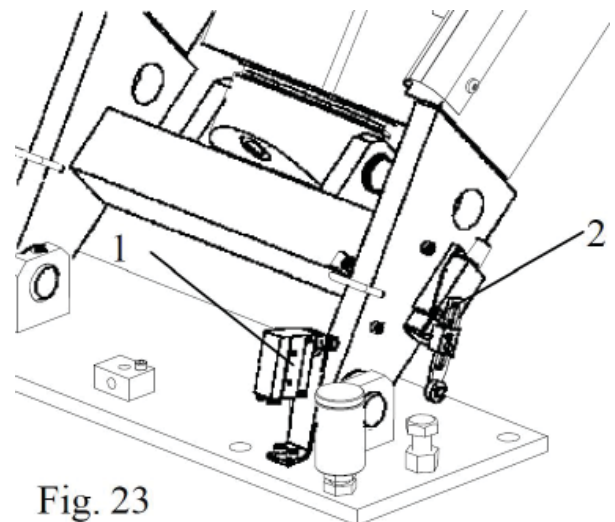

Fig. 23

## 7.10.2 Safety Height Limit Switch

- Place the lift at a desired height (16 inches from the floor is suggested);
- Mount the switch (2) onto the thread holes on the arm using the included screws;
- Lower the lift at the safety height to check the limit switch for proper installation;
- If the switch was not functioning properly, it's possible to adjust it by unloosing the switch lever and changing its position;
- Tighten the screw after adjustment.
- Fix the switch cover with the supplied screws.

## 7.11 Installation Of The Rear Beam

- Install the 2 rolling jacks on the runways;
- Make all air connections to the rolling jacks;
- Install the rear cross beam (ref. Fig. 22).

Fig. 24

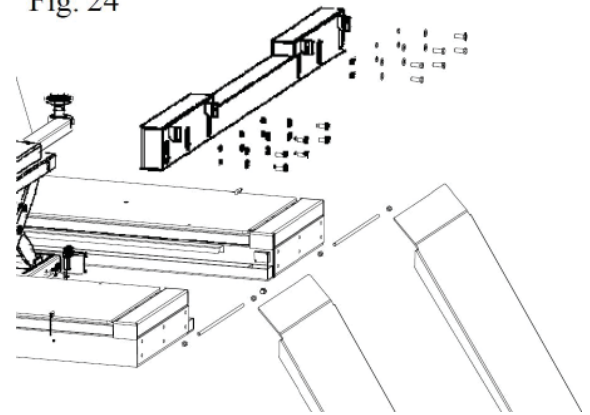

 **The rear beam must be installed on the lift after bleeding procedure.**

 **The rear beam must be attached to the runways when 2 rolling jacks are needed for lifting a vehicle. Otherwise, the manufacturer will not be responsible for any damage of the lift.**

## 7.12 Checks Less Load



**During this procedure, observe all operating components and check for proper installation and adjustment. DO NOT attempt to raise vehicle until a thorough operation check has been completed.**

Be sure the lift fixing to the ground and all anchor bolts tightened.

Carry out two or three complete cycles of lowering and lifting and check:

- The lift is properly anchored and bolts tightened
- The safety locks for proper operation
- Proper oil level in the tank
- No leakage and blow-by in hydraulic line
- Cylinder for proper operation
- The level of the platforms and jacks
- The lift for reaching its maximum height
- The maximum height limit switch operates properly
- The safety limit switch operates properly
- The beeper during final travel

## 7.13 Checking With Load

Carry out two or three complete cycles of lowering and lifting and check:

- Repeat the 7.12 section
- Check no strange noise during lifting and lowering
- If the platforms or jacks weren't leveled, repeat the 7.8 section

# Operation And Use

Never operate the lift with any person or equipment below.  
Never exceed the rated lifting capacity.

Always ensure that the safety locks are engaged before any attempt is made to work on or near the vehicle, and two platforms **MUST** be in equal height from the floor when resting on the safeties.

Never leave the lift in an elevated position unless the safeties are engaged.

If an anchor bolt becomes loose or any component of the lift is found to be defective, **DO NOT USE THE LIFT** until repairs are made.

Do not permit the electric control unit to get wet!

## 8.1 Controls

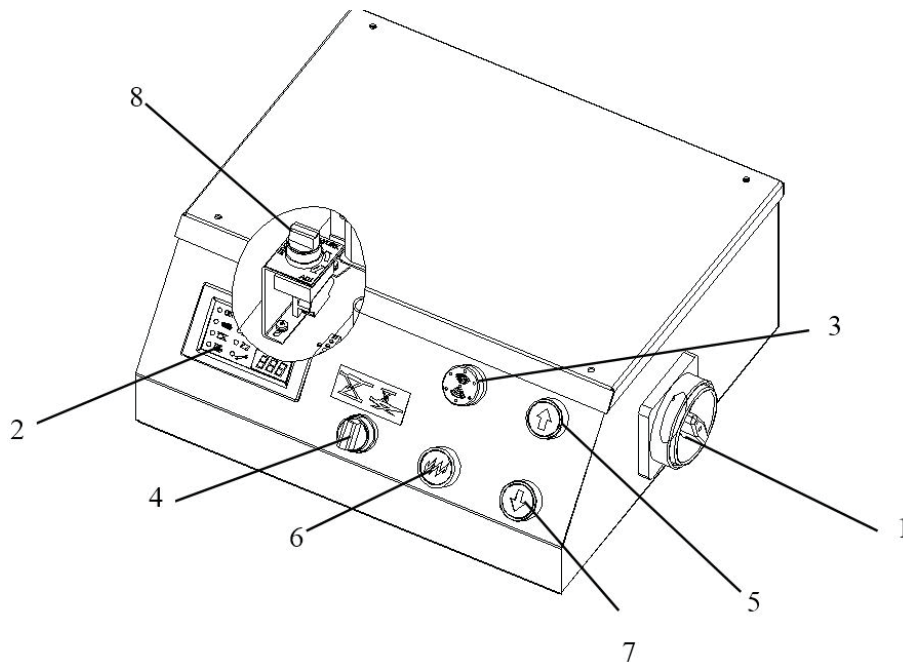

Figure 25 – Control Panel











Controls for operating the lift are:

## POWER SWITCH (1)

The power switch can be set in two positions:

- **0 position:** the lift electric circuit is not powered; the switch can be padlocked to prevent the use of the lift.
- **1 position:** the main electric circuit is powered.

## DISPLAY WINDOW (2)



- When ON lights, it shows that the electric circuit is powered.
- When  lights, it shows that top limit switch is working.
- When  lights, it shows that the safety height limit switch is working.
- When  lights, it shows that the hydraulic power unit is working.
- When  lights, it shows that the runways are being operated.
- When  lights, it shows that the wheel free jacks are being operated.
- When  lights, it shows that the lift is in bleeding (ADJ) process.
-  shows the safety release time which is preset by the manufacturer if no special request.
- When  lights, it shows that the play detector is working if it is ordered with the lift.

## BEEPER (3)

- It activates when the runways are lowered at the safety height.

## MAIN/JACK SELECTOR (4)

The selector can be set in two positions:



- **Position**  : the runway electric circuit is powered for operation
- **Position**  : the electric circuit for wheel free jack is powered for operation



## LIFTING BUTTON (5)

- When pressed, the electric circuit operates the motor and hydraulic circuit to raise the runways or the wheel free jacks depending on the position the selector (4) is set.

## SAFETY ENGAGING BUTTON (6)

- When pressed, the mechanical safeties on the runways start to engage the nearest racks if MAIN/JACK selector is set to the position .
- When pressed, the mechanical safeties on the wheel free jacks start to engage the nearest racks if MAIN/JACK selector is set to the position .

## LOWERING /FINAL LOWERING BUTTON (7)

- When pressed, at first the lift takes 1-2 seconds to clear off the safety, and then descends to the safety height.
- When pressed with the lift at the safety height, the lift is lowered to the ground. A beep sound is heard during the last travel.

	<b>Be sure the safety area is free from people and objects during the final travel.</b>
---	---

## ADJ/WORK SELECTOR (8)

- **Position WORK**, the lift can be for the normal operation.
- **Position ADJ**, the lift can be for bleeding operation.

	<b>Make sure that two runways MUST be in equal height from the floor when resting the safeties.</b>
	<b>Always ensure that the safeties are engaged before any attempt is made to work on or near the vehicle.</b>
	<b>Make sure to engage the mechanical safety locks when the vehicle is left on the runways for long periods (ex. during the night).</b>

Lift operation can be summarized into following steps:

## 8.2 To Raise Runways

- Position the vehicle at the center of the runways. Check to make sure that the vehicle is secured;
- Set the power switch to 1 position;
- Set the main/jack selector to MAIN position;
- Press the lifting button to raise the vehicle;
- To rest the runways in standing position at the desired height by releasing the lifting button;
- Push the safety button to engage the mechanical safeties.

## 8.3 To Lower Runways

- Be sure the safety area is free of people and objects;
- Raise the runways a little bit by pushing the lifting button to clear off the mechanical safeties;
- Press the lowering button: the runways will take seconds to release the safeties and then begins to descend lower under its weight and the load lifted;
- Keep pressing the lowering button until the runways are lowered to the safety height;
- Press the final lowering button until the runways are lowered completely. A beep sound is heard during the last travel.

## 8.4 Raising The Wheel Free Jacks

- Place the rubber blocks under the picking point at the car. Adjust jack table extensions according to vehicle to lift if necessary;
- Check to make sure that the vehicle is secured;
- Place pads under the positions indicated for lifting, by the motor vehicle's manufacturer;
- Set the main/jack selector to the position ;
- Press the lifting button to lift the vehicle to the required height;
- To rest the jacks in standing position at the desired height by releasing the lifting button;
- Push the safety engaging button to engage the mechanical safeties.

## 8.5 Lowering The Wheel Free Jacks

- Be sure the safety area is free of people and objects;
- Raise the jacks a little bit by pushing the lifting button to clear off the mechanical safeties;
- Press the lowering button: the jacks will take seconds to release the safeties and then begins to descend lower under its weight and the load lifted.
- Keep pressing the lowering button until the jacks are lowered completely.

## 8.6 Runway Leveling



After a period of service, due to natural loss of the oil or trapped air in the hydraulic line, it could be possible that the runway P2 (the slave runway) is lower than the runway P1 (the master runway). In this case, level the runways following these instructions:

- Raise the runways at approximate 12”;
- Set ADJ/WORK selector into the position “ADJ”;
- Turn on the leveling cutoff cock 1 (ref. Fig. 19);
- Feather-pushing the lifting button or the lowering button if necessary to adjust the height of the runway P2;
- Turn off the leveling cutoff cock 1 after the runway P2 reaches at the same height as the runway P1;
- Set ADJ/WORK selector into the position “WORK” after the adjustment.

## 8.7 Manual Emergency Lowering

In case of an emergency the runways or wheel free jacks can be lowered manually to its initial position as follows referring to the Figure 26 and the Figure 27:

- Padlock the power switch;
- Open the front cover of the control unit;

## 8.7.1 To Lower Runways Manually

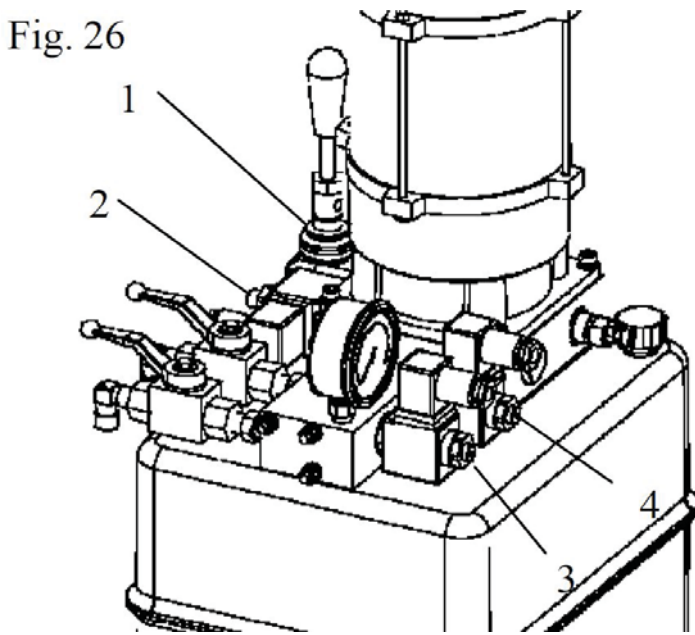
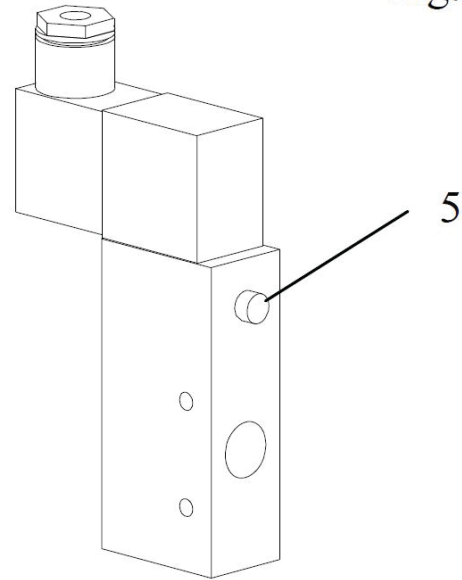

Fig. 27



To lower the runways, proceed following the following procedures:

- Set the MAIN/JACK selector to "X";
- If the mechanical safeties are engaged, keep pushing the slider (3) of the solenoid valve using a proper pin;
- Operate the emergency hand pump (1) to raise the runways a little bit to clear off the mechanical safeties.
- Referring to the pneumatic diagram (Figure 17) to locate the solenoid air valve for the runways, keep pressing the emergency button;
- Unloosen the emergency screw (2) of the lower solenoid valve by turning it anticlockwise.
- Tightening or loosening the screw can reduce or increase the lowering speed;
- Keep pushing the slider (3) of the solenoid valve using a proper pin until the runways are lowered completely;
- Re-tighten the emergency screw (2) by turning it clockwise after the runways are lowered.



**When a mechanical safety is released, it is advised to use a carton board to put between the safety pawl and the rack to avoid it from engaging. In this case, do not need to press the emergency button continuously. Tightening or loosening the screw can reduce or increase the lowering speed.**

## 8.7.2 To Lower Wheel Free Jacks Manually

To lower the wheel free jacks, proceed following the following procedures:

- Set the MAIN/JACK selector to “”;
- If the mechanical safeties are engaged, keep pushing the slider (4) of the solenoid valve using a proper pin;
- Operate the emergency hand pump (1) to raise the wheel free jacks a little bit to clear off the mechanical safeties;
- Referring to the pneumatic diagram (Figure 17) to locate the solenoid air valve for wheel free jacks, keep pressing the emergency button;
- Loosen the emergency screw (2) of the lower solenoid valve by turning it counter-clockwise and in the meantime keep pushing the slider (4) until the jacks are lowered completely;
- Tightening or loosening the screw can reduce or increase the lowering speed;
- Keep pushing the slider (4) of the solenoid valve using a proper pin until the jack beams lowered completely;
- Re-tighten the emergency screw (2) by turning it clockwise after the jacks are lowered.

## 8.8 Operation Of Jack Beam (Optional)

The jack beam is to be operated by an air-hydraulic pedal pump supplied with the lift.

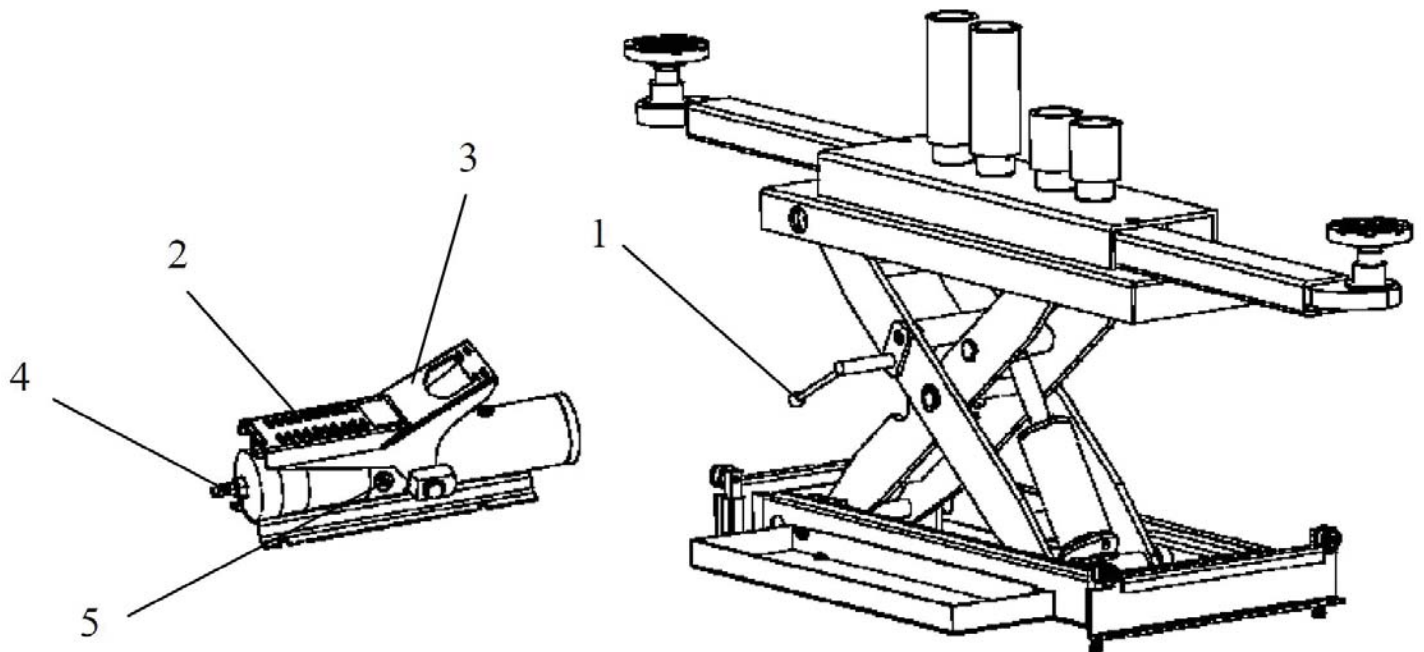

Figure 28 - Jack Beam Controls

## SAFETY LEVER (1)

- When turned up, the jack safety is released.
- When turned down, the jack safety can be locked.

## LIFTING PEDAL (2)

- When pressed, the hydraulic fluid is started to be delivered from the oil reservoir of the pump into the jack cylinder: the jack beam begins to rise.

## LOWERING PEDAL (3)

- When pressed, the hydraulic fluid is started to be released from the jack cylinder into the oil reservoir of the pump: the jack beam begins to descend under the weight loaded.
- The lowering speed can be controlled by change of the foot pressing force on the pedal.

## AIR HOSE FITTING (4)

- It is to be connected with the air hose to the compressed air.

## FLUID PORT(5)

- It is to be connected with the hydraulic hose from the pump to the jack beam cylinder.

## 8.8.1 To Raise The Jack Beam



**Never raise the jack beam over high than the rated height. The manufacturer will not be responsible for the damage because of the incorrect operation.**

- Check to be sure the hydraulic hose and the air hose are connected properly;
- Check to be sure the oil in the pump tank is sufficient;
- Adjust extensions according to vehicle;
- Adjust the lifting adaptor height properly. If necessary, place the appropriate extensions on the lifting adaptors.

- Make sure the vehicle is secured;
- Raise the jack by pressing the lifting pedal on the pump.

## **8.8.2 Standing**

- To rest the vehicle at the desired height by releasing the lifting pedal;
- Place the safety pawl on the nearest safety rack by turning down the safety lever;
- Lower the jack beam by depressing the lowering pedal on the pump to engage the safety.
- Check to make sure the mechanical safety is engaged before entering the work area.

## **8.8.3 To Lower The Jack Beam**

- Be sure the under jack is free of any objects;
- Raise the jack beam a little bit by depressing the lifting pedal;
- Release the mechanical safety by turning up the safety lever;
- Depressing the lowering pedal on the pump until the jack beam is lowered completely.

# Maintenance

---



**Only trained personnel who knows how the lift works, must be allowed to service the lift.**

To service properly the lift, the following has to be carried out:

- Use only genuine spare parts as well as equipment suitable for the work required;
- Follow the scheduled maintenance and check periods shown in the manual;
- Discover the reason for possible failures such as too much noise, overheating, oil blow-by, etc.

Refer to documents supplied by the dealer to carry out maintenance:

- Functional drawing of the electric and hydraulic equipment
- Exploded views with all data necessary for spare parts ordering
- List of possible faults and relevant solutions.



**Before carrying out any maintenance or repair on the lift, disconnect the power supply, padlock the general switch and keep the key in a safe place to prevent unauthorized persons from switching on or operating the lift.**

## 9.1 Ordinary Maintenance

The lift has to be properly cleaned at least once a month using self-cleaning clothes. Lubricate all pivot pins at least once a week.



**The use of water or inflammable liquid is strictly forbidden.**



Be sure the rod of the hydraulic cylinders is always clean and not damaged since this may result in leakage from seals and, as a consequence, in possible malfunctions.

## 9.2 Periodic Maintenance

Every 3 months	Hydraulic circuit	check oil tank level; refill with oil, if needed; check the circuit for oil leakage. check seals for proper conditions and replace them, if necessary;
	Foundation bolts	check bolts for proper tightening
	Hydraulic pump	verify that no noise changes take place in the pump when running and check fixing bolts for proper tightening
	Safety system	check safety devices for proper operation
Every 6 months	Oil	check oil for contamination or aging. Contaminated oil is the main reason for failure of valves and shorter life of gears pumps
Every 12 months	General check	verify that all components and mechanisms are not damaged
	Electrical system	a check of the electrical system to verify that motor, limit switch and control panel operate properly must be carried out by skilled electricians
	Oil	empty the oil tank and change the hydraulic oil

# Troubleshooting

---

A list of possible troubles and solutions is given below:

<b>TROUBLE:</b>	<b>POSSIBLE CAUSE:</b>	<b>SOLUTION:</b>
	The main switch is not turned on	Turn the switch on
The lift does not work	There is no power	Check power and restore if necessary
	The electrical wires are disconnected	Replace
	Fuses are blown	Replace
	The one of limit switches is faulty.	Check the switch and relevant connection for proper operation. Replace, if needed.
The lift does not raise when the UP button is pressed	The motor direction of rotation is not correct	Interchange the phases on the main switch
	The oil in the hydraulic unit is not sufficient	Add some hydraulic oil
	The UP button is faulty	Check UP button and connection for proper operation. Replace, if needed
	The lowering solenoid valve does not close	Check and clean, if dirty, or replace, if faulty
	The emergency screw of lowering valve does not close	Re-tighten the screw
	The suction pump filter is dirty	Check and clean if needed

The lift does not lower when DOWN button is pressed	The motor does not operate properly and does not release the mechanical safeties	Check the motor
	The lift goes up instead of going down	
	-Because solenoid air valve is faulty	Replace air solenoid valve
	-Because the air does not reach the circuit	Verify the compressor and air hose ability
	-Because electric board is faulty	Replace electric board
	The lowering solenoid valve does not discharge	Verify if it is powered and check the magneto for damages (replace if disconnected or burnt)
	The lowering solenoid valve is not operating	Verify if it is powered and check the magneto for damages (replace if disconnected or burnt)
The lift does not stop at the safety height	The DOWN button is faulty	Check the DOWN button and connection for proper operation. Replace, if needed
	The safety height limit switch is not adjusted correctly or it is faulty	Adjust or change the limit switch
	The electric board is faulty	Clean, if necessary replace or verify if powered and check magneto for damage
	The electric board is not operating	Replace electric board

The lift does not stop at the safety height	The motor does not operate properly and does not release the mechanical safeties	Check the motor
	The DOWN button is faulty	Check the DOWN button and connection for proper operation. Replace, if needed
	The electric board is faulty	Replace electric board
The lift isn't raising synchronous	Presence of air or dripping in the hydraulic circuit	Bleed the hydraulic circuit
	The cylinder gaskets can be damaged	Check and replace if necessary
The lifting capacity is not sufficient	The oil in the tank is not enough	Fill oil in the tank
	The pump is faulty	Check the pump and replace if necessary
	The maximum pressure valve is not adjusted correctly	Adjust correctly
The lift does not lift or lower smoothly	Leakages or presences of air into hydraulic circuit	Bleed the hydraulic system
The motor does not stop when reaching it maximum height	The maximum height limit switch does not work	Check the limit switch and replace if needed
The lift does not lift or lower smoothly	Leakages or presences of air into hydraulic circuit	Bleed the hydraulic system
	The pump filter is dirty.	Check and clean if needed.
	The pump suction is blown	Check the seal and replace if needed

# Parts List

## Lift Illustration

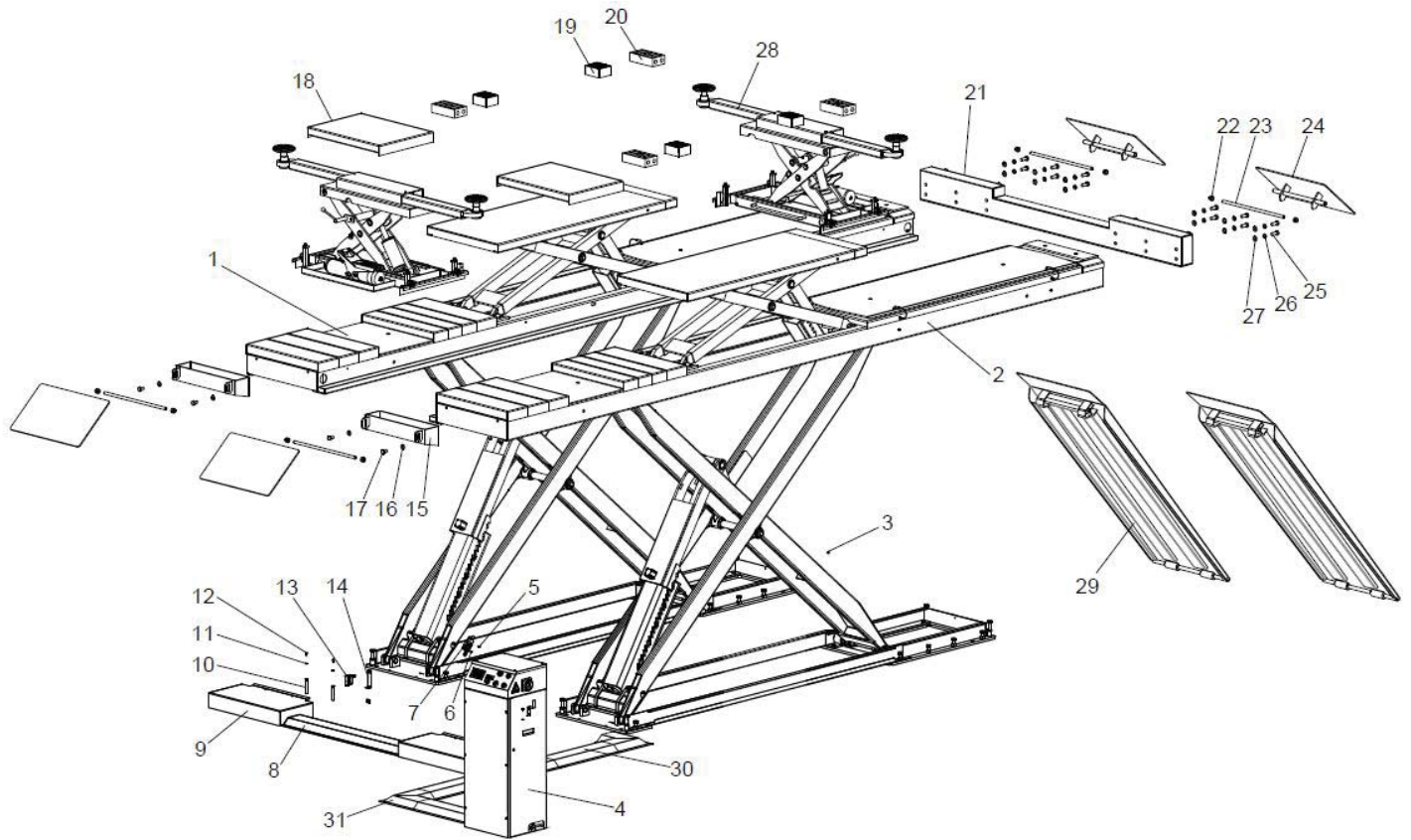

## Lift Parts List

Item	Part Num	Description	Qty
1	825DL1-100000	Runway P1	1
2	825DL1-200000	Runway P2	1
3	0206036	Screw M6X8 - GB/T818	1
4	8240D03000	Control unit	1
5	0206013	Screw M4X12 - GB/T818	1
6	0206017	Screw M4X25 - GB/T818	1
7	0505018	Safety position limit switch 8108	1

Item	Part Num	Description	Qty
8	8240TX-000862	Front hose cover for on-ground installation (Optional)	2
9	824-000001	Front cover (Optional)	2
10	824-000002	Special screw M12X80	4
11	0205006	Washer D.6 - GB/T97.1	4
12	0202024	Screw M6X12 - GB/T70.1	6
13	0505017	Top position limit switch 7311	1
14	CJS30-01-04	Switch support	1
15	824-000100	Front ramp support	2
16	0205017	Washer D.14 - GB/T97.1	4
17	0201085	Screw M14X25 - GB/T5781	4
18	8200TY-800002	Turntable recess cover	2
19	0606033	Rubber pad 115X100X55	4
20	0606032	Rubber pad 180X100X50	4
21	8240TXKL-4G	Rear beam	1
22	0204008	Self-locking nut M16 - GB/T889.1	8
23	8200B6-800012	Ramp pin	4
24	8200TX-007100	Short ramp	4
25	0201130	Screw M16X40- GB/T5783	12
26	0208011	Washer D.16- GB/T93	12
27	0205020	Washer D.16- GB/T97.1	12
28	J07Q	Jacking beam HJ-75B	2
29	J62B400000	Long ramp for on-ground installation (Optional)	2
30	8240TX-000863	Hose corner cover for on-ground installation (Optional)	2
31	8240B-008640	Hose cover for on-ground installation (Optional)	2

# Runway P1 Illustration

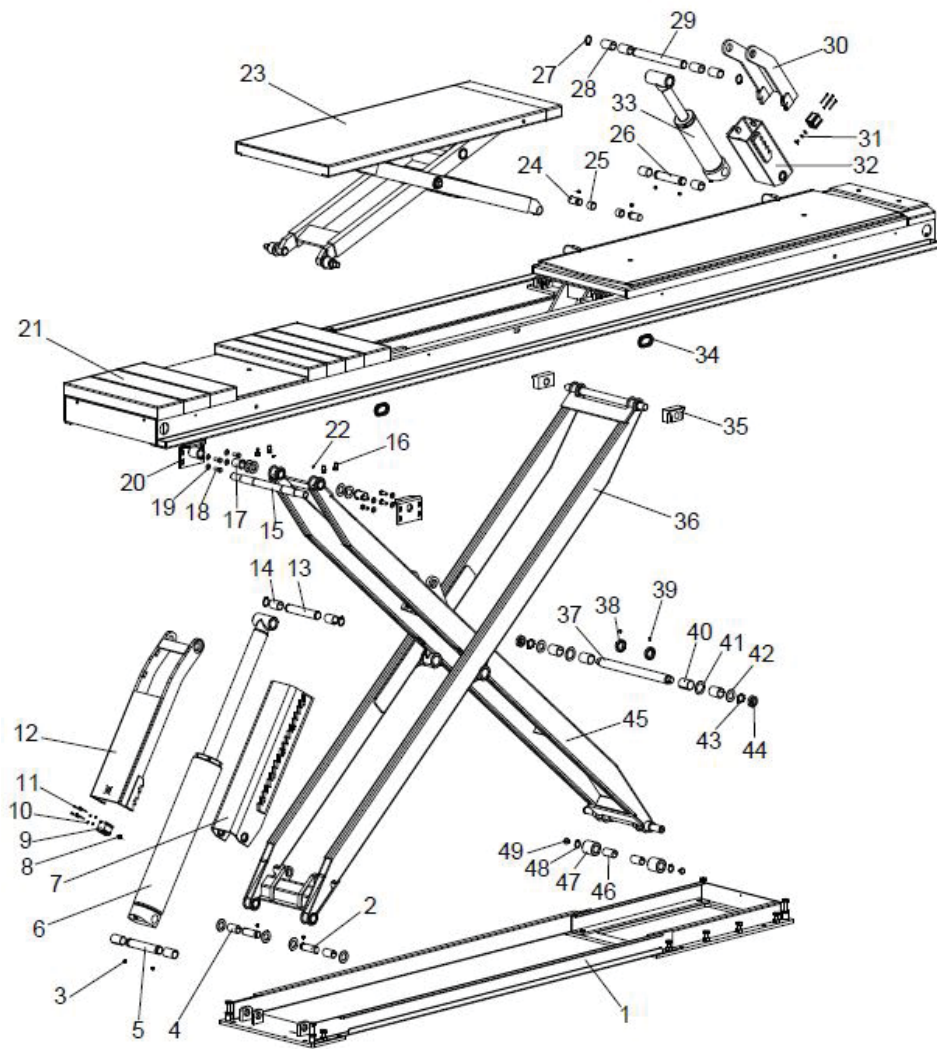

## Runway P1 Parts List

Item	Part Num	Description	Qty
1	824-110000G	Base	1
2	824-100003	Lower shaft	2
3	0209025	Screw M8X12 - GB/T79	8
4	0210018	Self-lubricated bush 3055	2
5	8250-02-01-17	Cylinder lower shaft	1
6	8250-120-00	Master hydraulic cylinder	1
7	8250-06-03	Lower safety rack	1
8	0511228	Screw M8X10	2
9	0306010	Air locking cylinder 32X23	2



Item	Part Num	Description	Qty
10	0205002	Washer D.4 - GB/T97.1	4
11	0202010	Screw M4X50 - GB/T70.1	8
12	824-161000	Upper safety rack	1
13	8250-02-01-18	Cylinder upper shaft	1
14	0210027	Self-lubricated bush 3550	4
15	824-100005	Upper shaft	1
16	0202070	Screw M12X20 - GB/T70.1	4
17	0210075	Self-lubricated bush 3050F	2
18	0201074	Screw M12X30 - GB/T5781	8
19	0205013	Washer D.12 - GB/T97.1	8
20	824-17000	Arm bracket	2
21	825DL1-140000	P2 platform assembly	1
22	0209010	Screw M6X10 - GB/T78	2
23	824-150000G	Wheel free jack assembly	1
24	8250-04-02-08	Jack lower shaft	2
25	0210013	Self-lubricated bush 3024	2
26	8250-06-01	Cylinder lower shaft	1
27	0212022	Seeger D.35 - GB/T894.1	4
28	0210028	Self-lubricated bush 3560	6
29	8250-07-01	Cylinder upper shaft	1
30	8250-07-02	Jack upper safety rack	1
31	0205008	Washer D.8 - GB/T97.1	2
32	8250-07-06	Jack lower safety rack	1
33	8250-00D	P1 jack hydraulic cylinder	1
34	CXQ-61X5.5	Hose holder	2
35	824-100001G	Nylon slider	2
36	824-130000G	Outer scissor arm	1
37	824-100004	Middle shaft	1
38	8250-02-26	Spacer	2
39	0209012	Screw M8X12 - GB/T78	2
40	0210080	Self-lubricated bush 4055	4
41	8250-18	Shim	2
42	ZJJ3-17	Shim	10



Item	Part Num	Description	Qty
43	0205025	Teethed washer D.30 - GB/T858	2
44	0204015	Nut M30 - GB/T6172.1	2
45	824-120000G	Inner scissor arm	1
46	0210046	Self-lubricated bush 3060	2
47	8240B-02-02-16	Lower wheel	2
48	0212021	Seeger D.30 - GB/T894.2	2
49	ZJJ3-02-01-08	Plug	2
50	8250-120-10	Master cylinder liner	1
51	8240B-120-04	Cylinder shaft	1
52	GJ350-120A-5	Piston	1
53	8250-120-06	Shaft support	1
54	0212007	Seeger D.32 - GB/T894.1	2
55	0309027	O-ring 38X3.1	2
56	0309012	O-ring 120X3.1	1
57	0309040	O-ring 75X5.7	1
58	0305006	Guide ring 67X25X2.5	1
59	0310019	Seal 67X77X6	1
60	0311013	Scraper 67X75X5	1
61	GJ350-120A-2	Cylinder guiding cover	1
62	0312007	Gasket 120X95X22.4	1
63	8250-80-40	PI jack cylinder liner	1
64	ZJJ40-02D	Piston	1
65	ZJJ40-04D	Cylinder shaft	1
66	ZJJ40-05D	Cylinder guiding cover	1
67	8250-06C	Shaft support	1
68	ZJJ40-07D	Air bleeding plug	1
69	0312016	Gasket 80X60X22.4	1
70	0309041	O-ring 80X3.1	1
71	0309030	O-ring 50X3.1	1
72	0305006	Guide ring 45X25X2.5	1
73	0311009	Scraper 45X53X5	1
74	0215059	Steel ball D.6	1

## Base Illustration

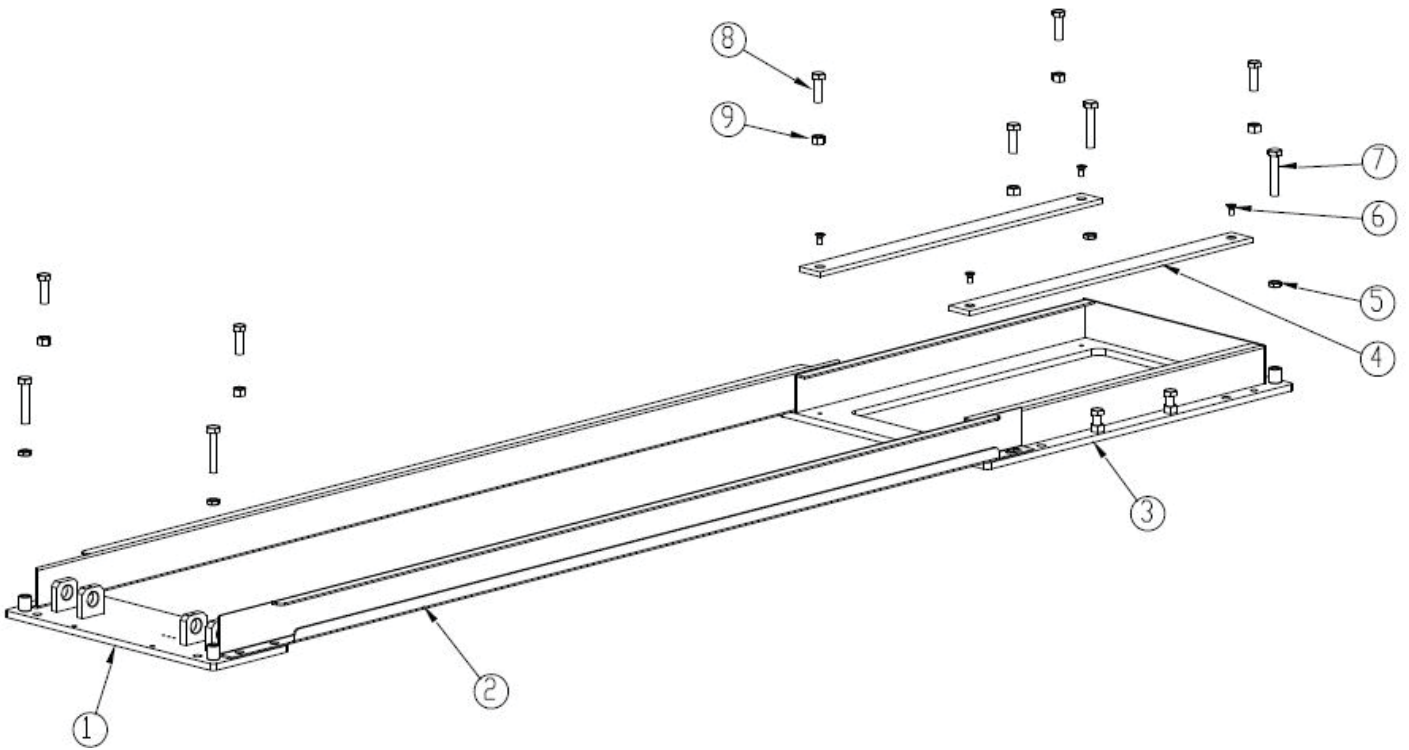

## Base Parts List

Item	Part Num	Description	Qty
1	824-111000	Front base	1
2	ZJJ3-0103	U connection rod	2
3	824-112000	Rear base	1
4	824-110001	Wheel guide	2
5	0204032	Nut M16 - GB/T6172.1	4
6	0207022	Screw M10X20 - GB/T819.1	4
7	0201180	Screw M16X85 - GB/T5780	4
8	0201103	Screw M16X50 - GB/T5781	10
9	0203025	Nut M16 - GB/T6170	10

# P1 Platform Assembly Illustration

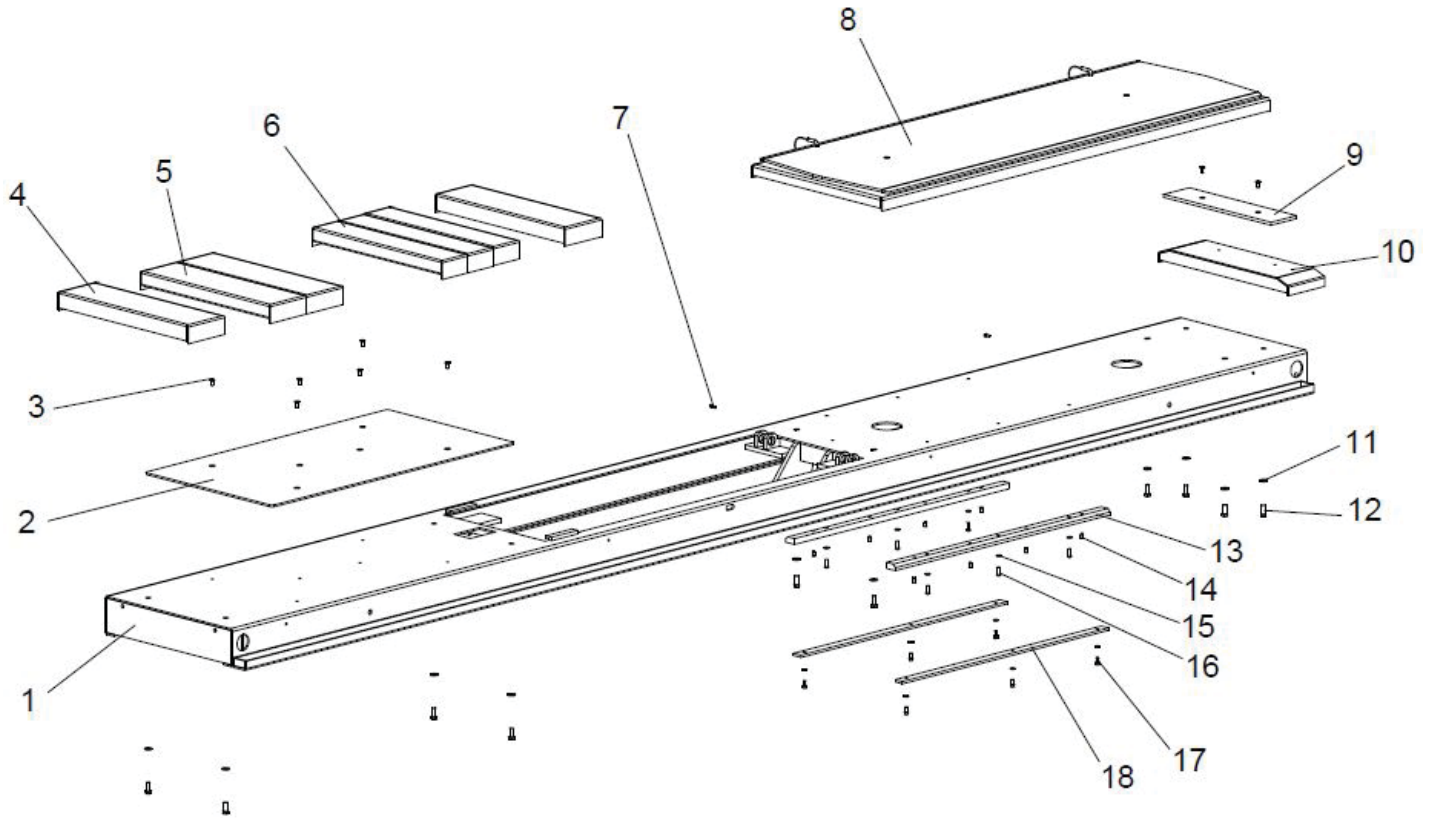

## P1 Platform Assembly Parts List

Item	Part Num	Description	Qty
1	825DL1-141000	P1 Platform	1
2	8250-000812	Turntable recess base plate	1
3	0207036	Screw M8X20 - GB/T70.3	8
4	8240B4-03150A	Spacer	2
5	8240B4-031501	Movable spacer	2
6	8240C4-031501	Movable spacer	3
7	0202032	Screw M6X16 - GB/T70.1	2
8	825D-145000	Slipping plate assembly	1
9	825D-000001	Spacer	1
10	825D-140100	Spacer	1
11	0205013	Washer D.12 - GB/T97.1	10
12	0201074	Screw M12X30 - GB/T5781	10

<b>Item</b>	<b>Part Num</b>	<b>Description</b>	<b>Qty</b>
13	824-140006	Upper wheel guide	2
14	0209028	Screw M10X16 - GB/T79	8
15	0205008	Washer D.8 - GB/T97.1	12
16	0206037	Screw M8X25 - GB/T70.2	6
17	0202040	Screw M8X16 - GB/T70.1	6
18	824-140007	Guide fastening plate	2

# Slip Plate Assembly Illustration

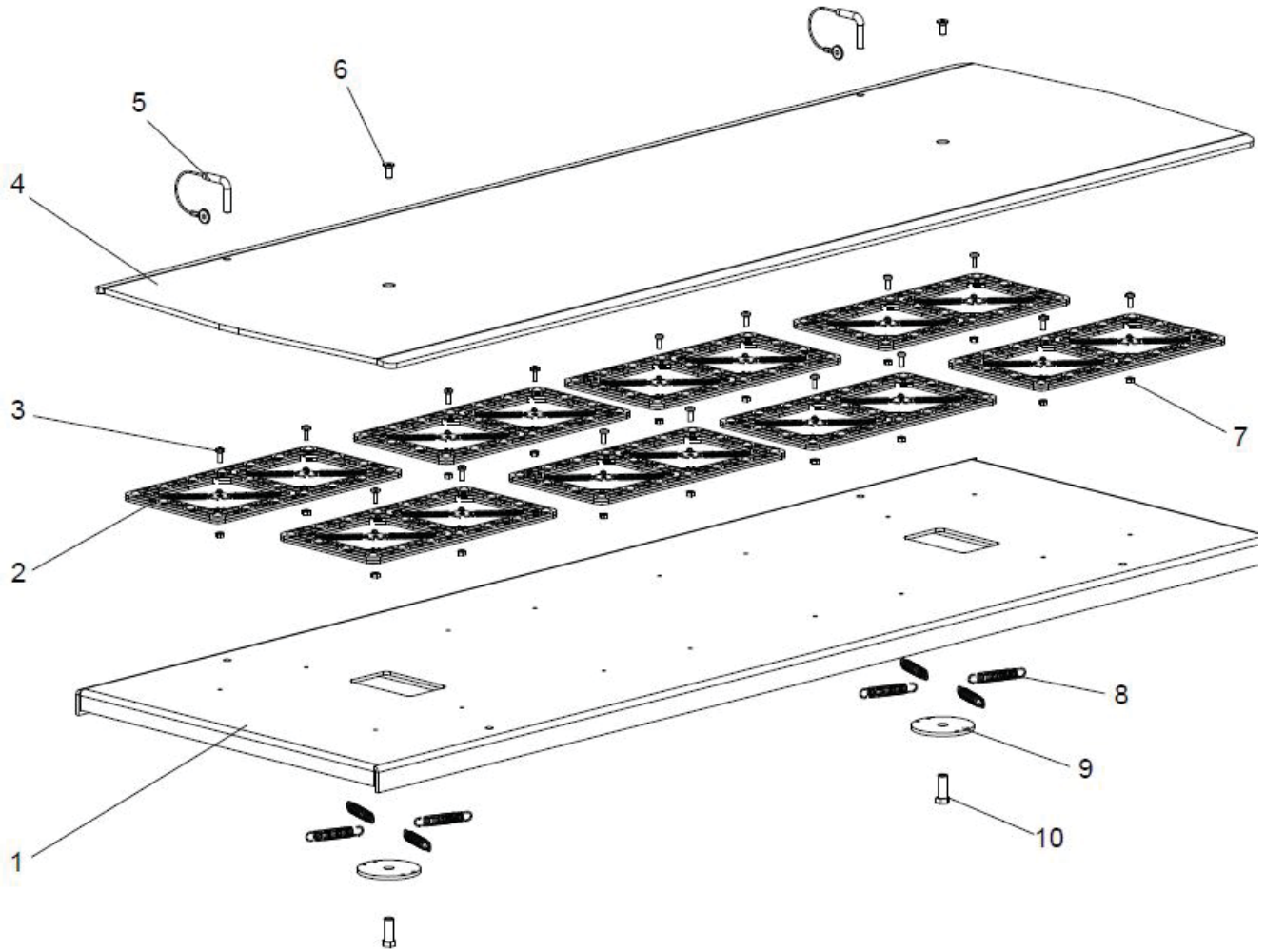

## Slip Plate Assembly Parts List

Item	Part Num	Description	Qty
1	825D-145100	Base plate	1
2	J63A332000	Roller gasket	8
3	0206032	Screw M6X16 - GB/T818	16
4	825D-142001	Slipping plate	1
5	824B-142200	Stop pin	2
6	0207036	Screw M8X20 - GB/T70.3	2
7	0203004	Nut M6 - GB52	16
8	XSZ-6-1	Spring	8
9	824EH000382	Spring cradle	2
10	824B-142003	Bolt - GB/T905	2

## Wheels Free Jack Assembly Illustration

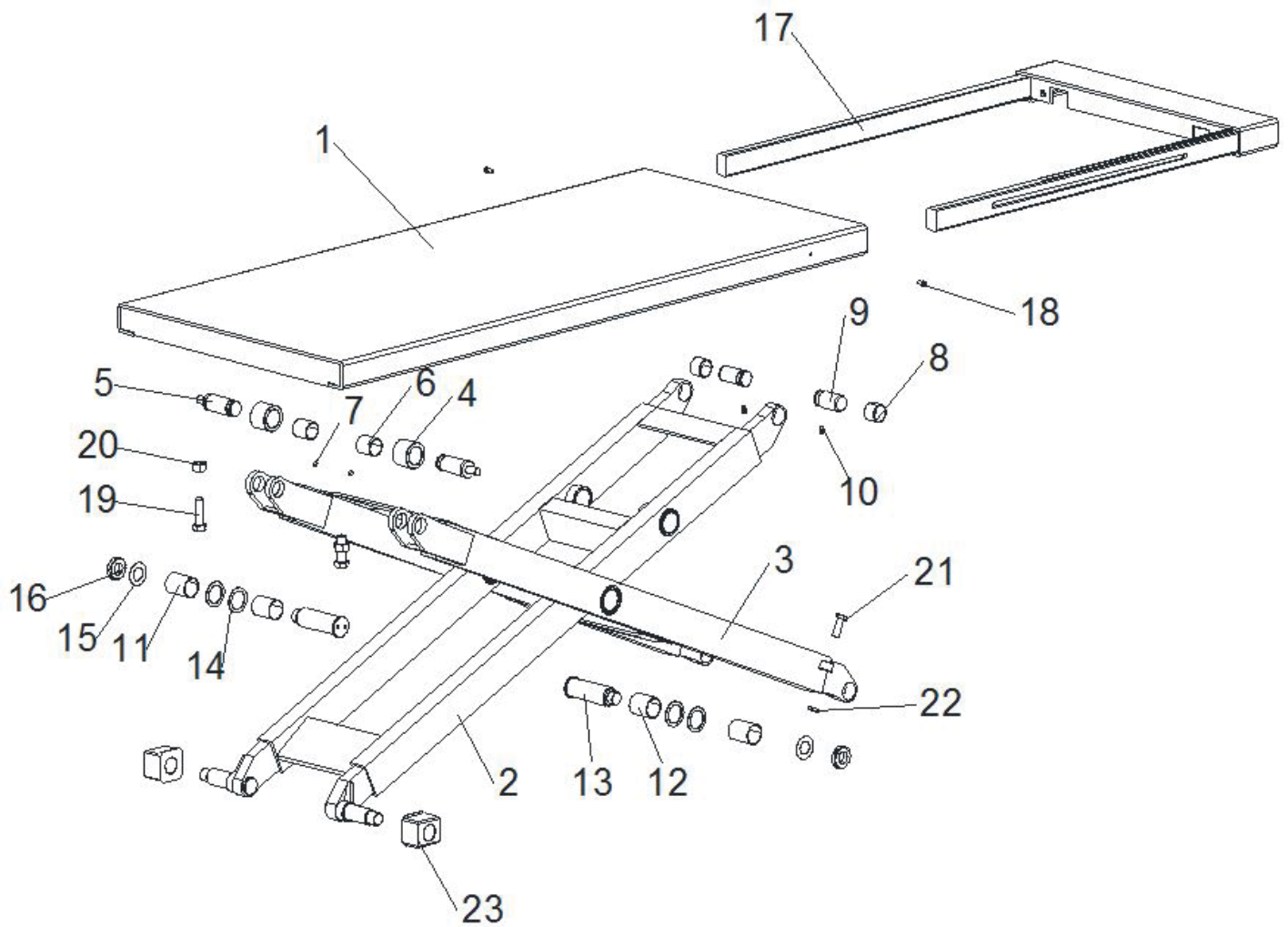

## Wheels Free Jack Assembly Parts List

Item	Part Num	Description	Qty
1	824-05-00	Jack table	1
2	824-153000	Inner scissor arm	1
3	824-152000	Outer scissor arm	1
4	8250-04-01-02	Upper wheel	2
5	8250-04-01-01	Upper wheel shaft	2
6	0210057	Self-lubricated bush 3035	2
7	0209002	Screw M6X10 - GB/T79	2
8	0210013	Self-lubricated bush 3024	2
9	8250-04-02-08	Upper shaft	2

Item	Part Num	Description	Qty
10	0209025	Screw M8X12 - GB/T79	2
11	0210027	Self-lubricated bush 3550	2
12	0210055	Self-lubricated bush 3545	2
13	824-04-01-08	Middle shaft	2
14	GJ300-400009	Shim 2	4
15	ZJJ3-04-01-09A	Spacer	2
16	0204060	Self-locking nut M25X1.5	2
17	824-05-9	Table extension	1
18	0202024	Screw M6X12 - GB/T70.1	2
19	0201103	Screw M16X50 - GB/T5783	2
20	0203025	Nut M16 - GB/T6170	2
21	0201220	Screw M12X35 - GB/T5783	2
22	0204016	Nut M12	2
23	824-150001	Lower slider	2



# Runway P2 Illustration

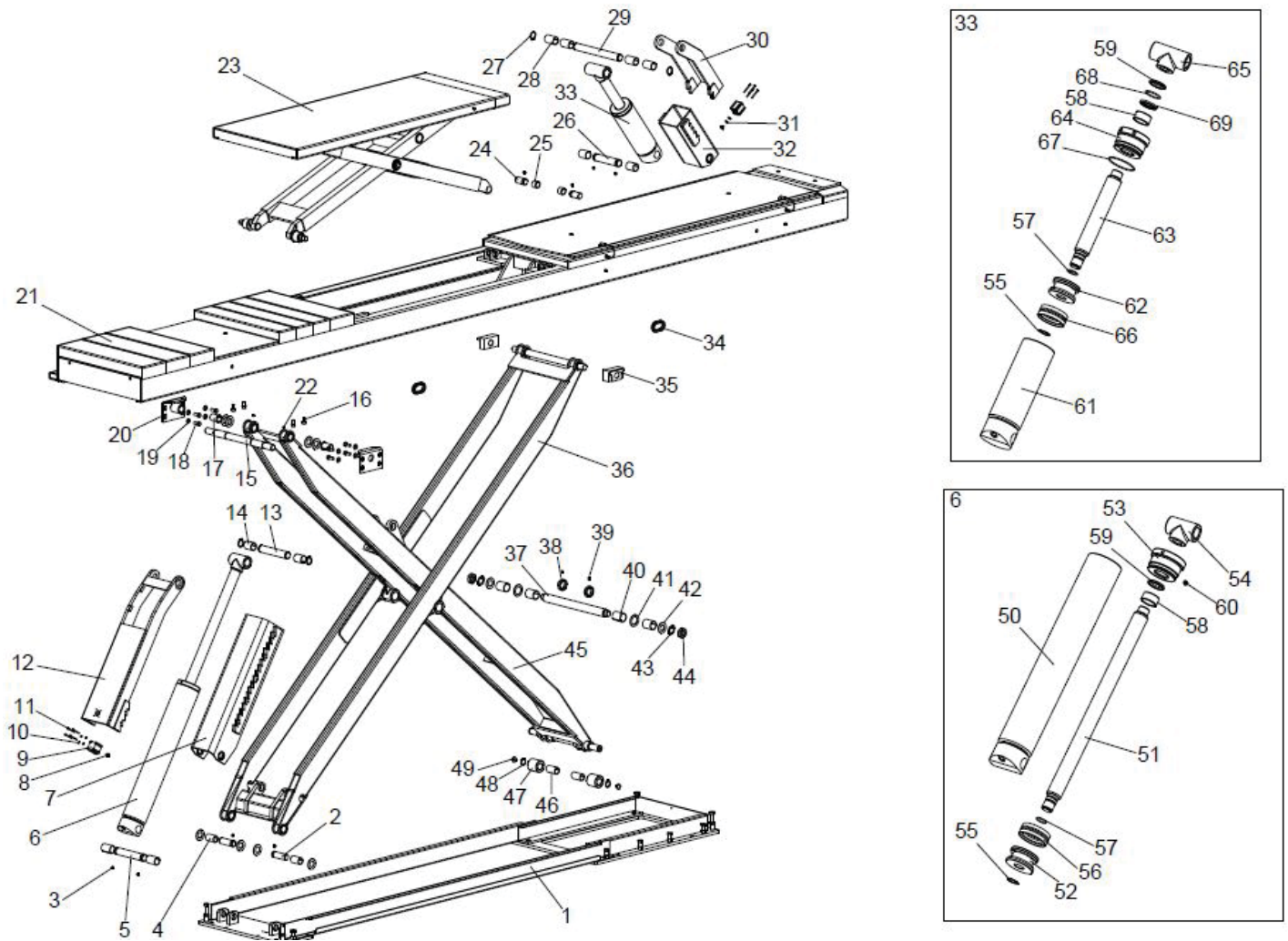

## Runway P2 Parts List

Item	Part Num	Description	Qty
1	824-110000G	Base	1
2	824-100003	Lower shaft	2
3	0209025	Screw M8X12 - GB/T79	8
4	0210018	Self-lubricated bush 3055	2
5	8250-02-01-17	Cylinder lower shaft	1
6	8250-100-00	Slave hydraulic cylinder	1
7	8250-06-04	Lower safety rack	1
8	0511228	Screw M8X10	2
9	0306010	Air locking cylinder 32X23	2



Item	Part Num	Description	Qty
10	0205002	Washer D.4 - GB/T97.1	4
11	0202010	Screw M4X50 - GB/T70.1	8
12	824-161000	Upper safety rack	1
13	8250-02-01-18	Cylinder upper shaft	1
14	0210027	Self-lubricated bush 3550	4
15	824-100005	Upper shaft	1
16	0202070	Screw M12X20 - GB/T70.1	4
17	0210075	Self-lubricated bush 3050F	2
18	0201074	Screw M12X30 - GB/T5781	8
19	0205013	Washer D.12 - GB/T97.1	8
20	824-17000	Arm bracket	2
21	825DL1-240000	P2 platform assembly	1
22	0209010	Screw M6X10 - GB/T78	2
23	824-150000G	Wheel free jack assembly	1
24	8250-04-02-08	Jack lower shaft	2
25	0210013	Self-lubricated bush 3024	2
26	8250-06-01	Cylinder lower shaft	1
27	0212022	Seeger D.35 - GB/T894.1	4
28	0210028	Self-lubricated bush 3560	6
29	8250-07-01	Cylinder upper shaft	1
30	8250-07-02	Jack upper safety rack	1
31	0205008	Washer D.8 - GB/T97.1	2
32	8250-07-03	Jack lower safety rack	1
33	8250-00C	P2 jack hydraulic cylinder	1
34	CXQ-61X5.5	Hose holder	2
35	824-100001G	Nylon slider	2
36	824-130000G	Outer scissor arm	1
37	824-100004	Middle shaft	1
38	8250-02-26	Spacer	2
39	0209012	Screw M8X12 - GB/T78	2
40	0210080	Self-lubricated bush 4055	4
41	8250-18	Shim	2
42	ZJJ3-17	Shim	10

Item	Part Num	Description	Qty
43	0205025	Teethed washer D.30 - GB/T858	2
44	0204015	Nut M30 - GB/T6172.1	2
45	824-120000G	Inner scissor arm	1
46	0210046	Self-lubricated bush 3060	2
47	8240B-02-02-16	Lower wheel	2
48	0212021	Seeger D.30 - GB/T894.2	2
49	ZJJ3-02-01-08	Plug	2
50	8250-100-10	Slave cylinder liner	1
51	8240B-100-04	Cylinder shaft	1
52	GJ350-100B-5	Piston	1
53	GJ350-100B-2	Cylinder guiding cover	1
54	8250-120-06	Shaft support	1
55	0212007	Seeger D.32 - GB/T894.1	2
56	0312003	Gasket 100X75X22.4	1
57	0309027	O-ring 38X3.1	2
58	0305006	Guide ring 50X25X2.5	2
59	0311010	Scraper50X58X5	2
60	0306087	Silencer 1/8	1
61	8250-95-30	P2 jack cylinder liner	1
62	ZJJ40-02B	Piston	1
63	ZJJ40-04C	Cylinder shaft	1
64	ZJJ40-05C	Cylinder guiding cover	1
65	8250-06C	Shaft support	1
66	0312019	Gasket 95X75X22.4	1
67	0309045	O-ring 95X3.1	1
66	0309031	O-ring 55X3.1	1
67	0310015	Seal 50X60X6	1

## P2 Platform Illustration

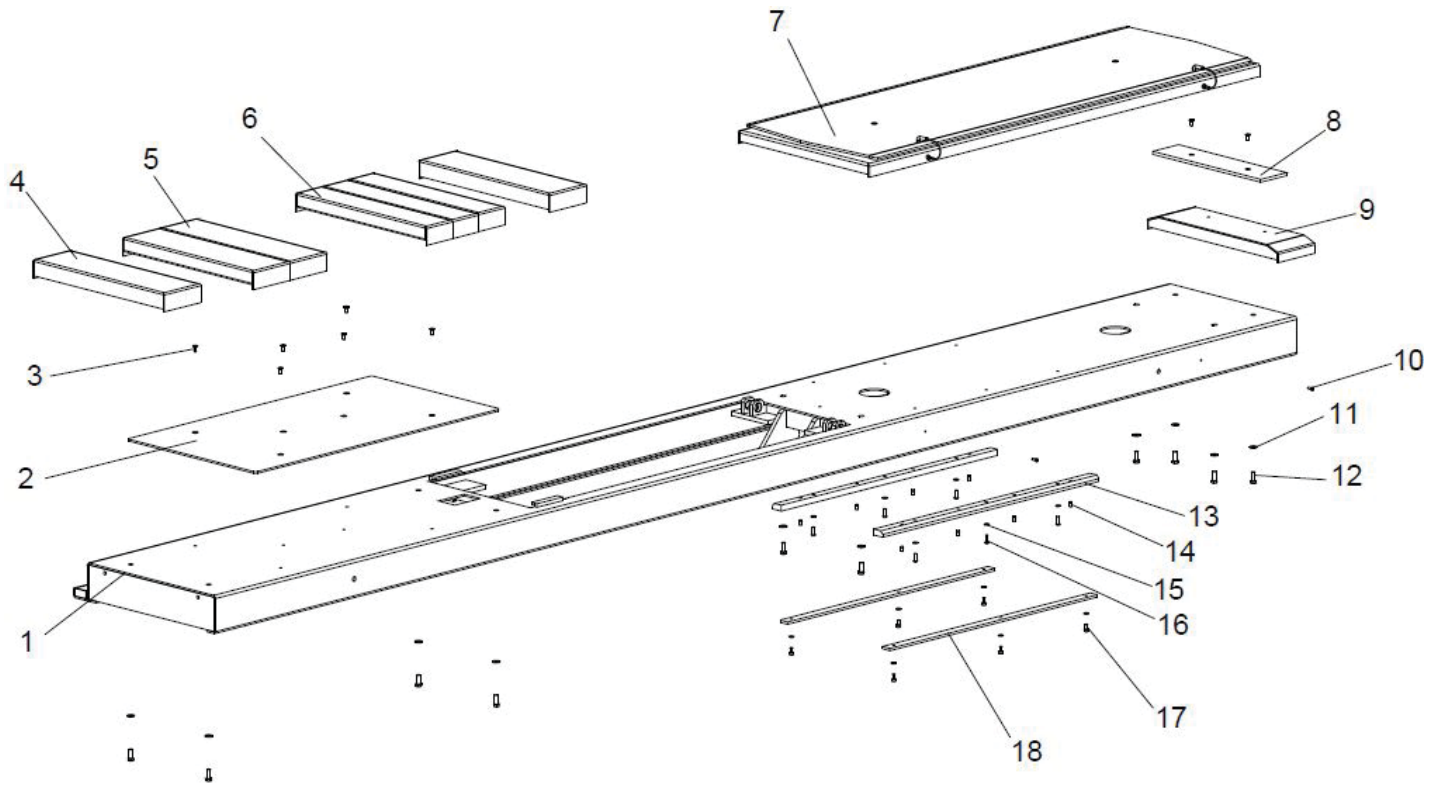

## P2 Platform Parts List

Item	Part Num	Description	Qty
1	825DL1-241000	P2 Platform	1
2	8250-000812	Turntable recess base plate	1
3	0207036	Screw M8X20 - GB/T70.3	8
4	8240B4-03150A	Spacer	2
5	8240B4-031501	Movable spacer	2
6	8240C4-031501	Movable spacer	3
7	825D-245000	Slipping plate assembly	1
8	825D-000001	Spacer	1
9	825D-140100	Spacer	1
10	0202032	Screw M6X16 - GB/T70.1	2
11	0205013	Washer D.12 - GB/T97.1	10
12	0201074	Screw M12X30 - GB/T5781	10
13	824-140006	Upper wheel guide	2

<b>Item</b>	<b>Part Num</b>	<b>Description</b>	<b>Qty</b>
14	0209028	Screw M10X16 - GB/T79	8
15	0205008	Washer D.8 - GB/T97.1	12
16	0206037	Screw M8X25 - GB/T70.2	6
17	0202040	Screw M8X16 - GB/T70.1	6
18	824-140007	Guide fastening plate	2

## Slip Plate 2 Assembly Illustration

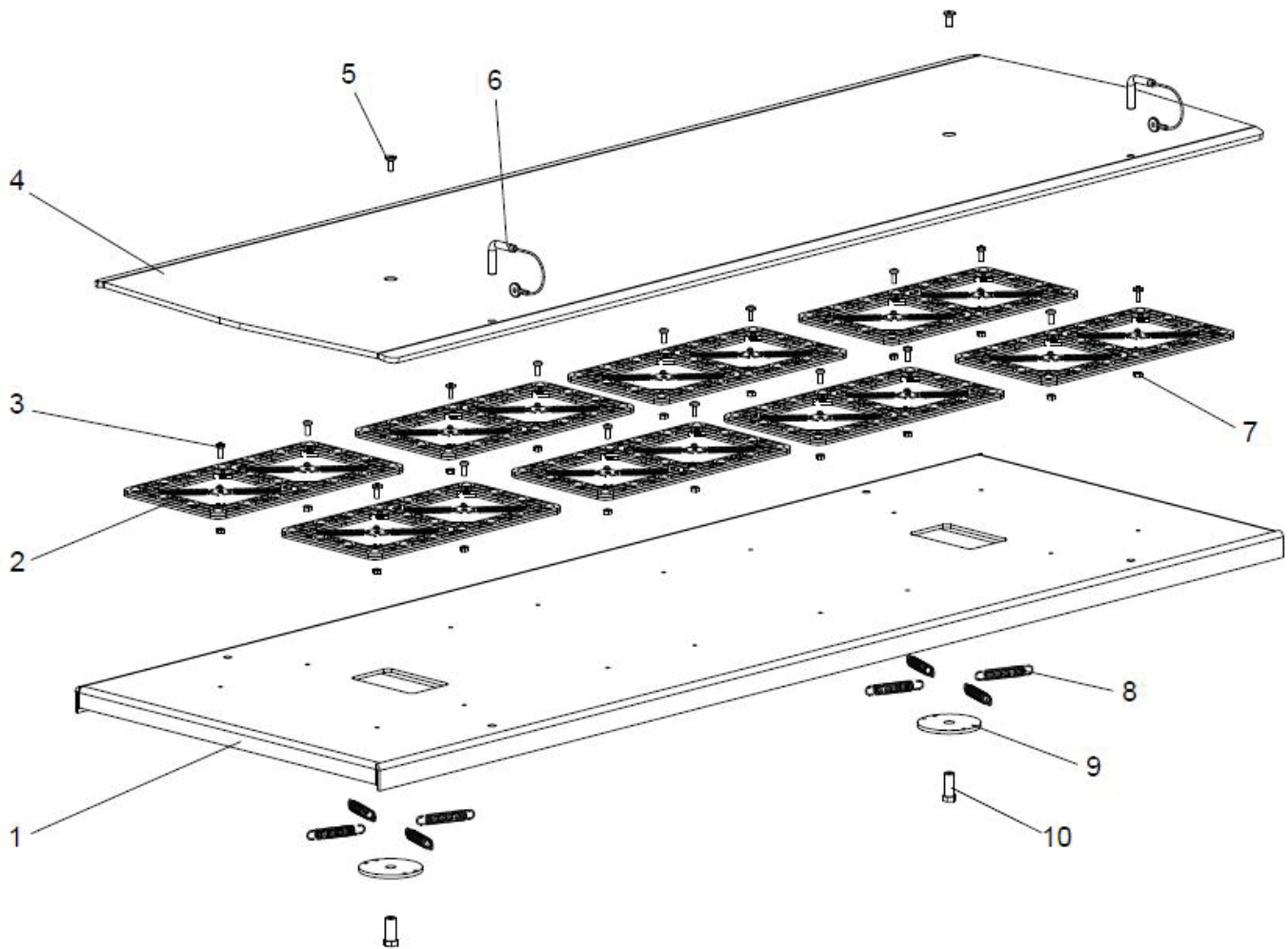

## Slip Plate 2 Assembly Parts List

Item	Part Num	Description	Qty
1	825D-145100	Base plate	1
2	J63A332000	Roller gasket	8
3	0206032	Screw M6X16 - GB/T818	16
4	825D-242001	Slipping plate	1
5	0207036	Screw M8X20 - GB/T70.3	2
6	824B-142200	Stop pin	2
7	0203004	Nut M6 - GB52	16
8	XSZ-6-1	Spring	8
9	824EH000382	Spring cradle	2
10	824B-142003	Bolt - GB/T905	2

## Control Unit Illustration

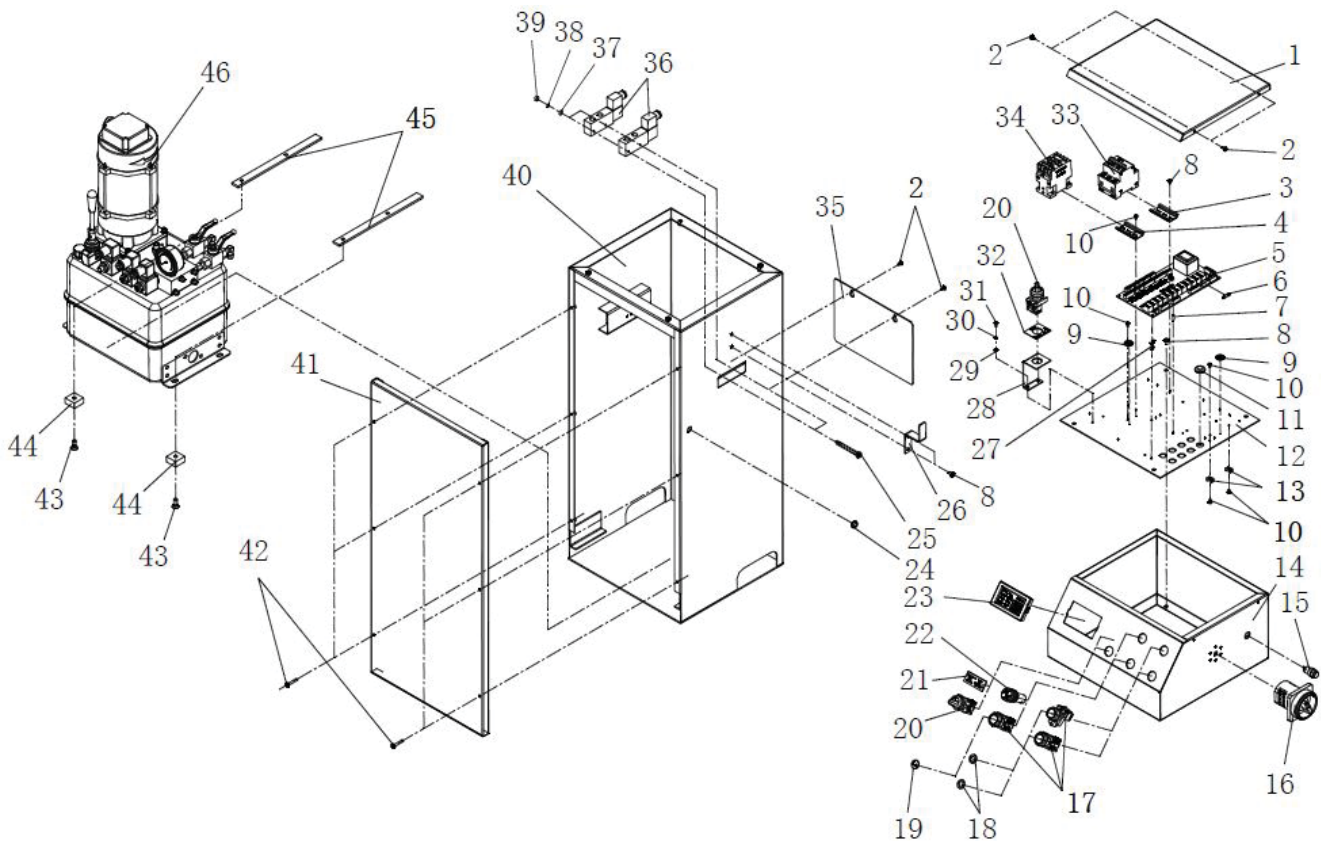

## Control Unit Parts List

Item	Part Num	Description	Qty
1	J04A030002	Top cover	1
2	0206059	Screw M4X8	6
3	0508330	Guide DZ47 L=80mm	1
4	0508330	Guide DZ47 L=45mm	1
5	0507349	CPU board 101.2	1
6	0504016	Fuse 1A(5X20)	3
7	0204077	Screw M3X12	2
8	0206058	Screw M5X10	6
9	0510380	Ground decal	2
10	0206019	Screw M4X6 - GB/T818	10
11	0508017	Cable relief GM-2314	8
12	J04A110001	Support	1
13	0508018	Holder HC-1(Φ4)	2
14	J04A113000	Top box	1

Item	Part Num	Description	Qty
15	0502017	Pushbutton LA16Y-11-Y	1
16	0505022	Power switch HZ5-2-20A	1
17	0502024	Pushbutton LAY37T-10	3
18	0510196	Up decal	2
19	0510196	Safety lock decal	1
20	0502004	Selector LAY37T-10X-2	2
21	0510379	Main/jack selector decal	1
22	0502021	Beeper AD16-22SM	1
23	0507163	Function display 502D	1
24	0508013	Cable relief GM-1710	1
25	0206071	Screw M3X60 - GB/T818	2
26	3002002009	Cable holder	1
27	0508302	Holder HDB-16A	4
28	3054502200	Support	1
29	0205002	Washer D.4 - GB/T97.1	2
30	0208002	Washer D.4 - GB/T93	2
31	0206023	Screw M4X8 - GB/T818	2
32	0510182	Decal	1
33a	0501066	Breaker DZ47-63/3P-D16A (For 400V/380V/3Ph)	1
33b	0501074	Breaker DZ47-63/2P/D32A (For 230V/220V/1Ph)	1
34	0501001	AC contactor CJX2-1210(220V)	1
35	3054503904	Back cover	1
36	0306177	Solenoid air valve G1/4 3V210-08(220V)	2
37	0205001	Washer D.3 - GB/T97.1	2
38	0208001	Washer D.3 - GB/T93	2
39	0203001	Nut M3 - GB52	2
40	J04A031000	Lower box	1
41	J04A030003	Front cover	1
42	0206028	Screw M5X25 - GT/T818	6
43	0207019	Screw M8X20 - GB/T819.1	4
44	3032084008	Rubber pad	4
45	3002005001	Support	2
46	BZ-W4K1Y	Hydraulic power unit	1



# Hydraulic Power Unit Illustration

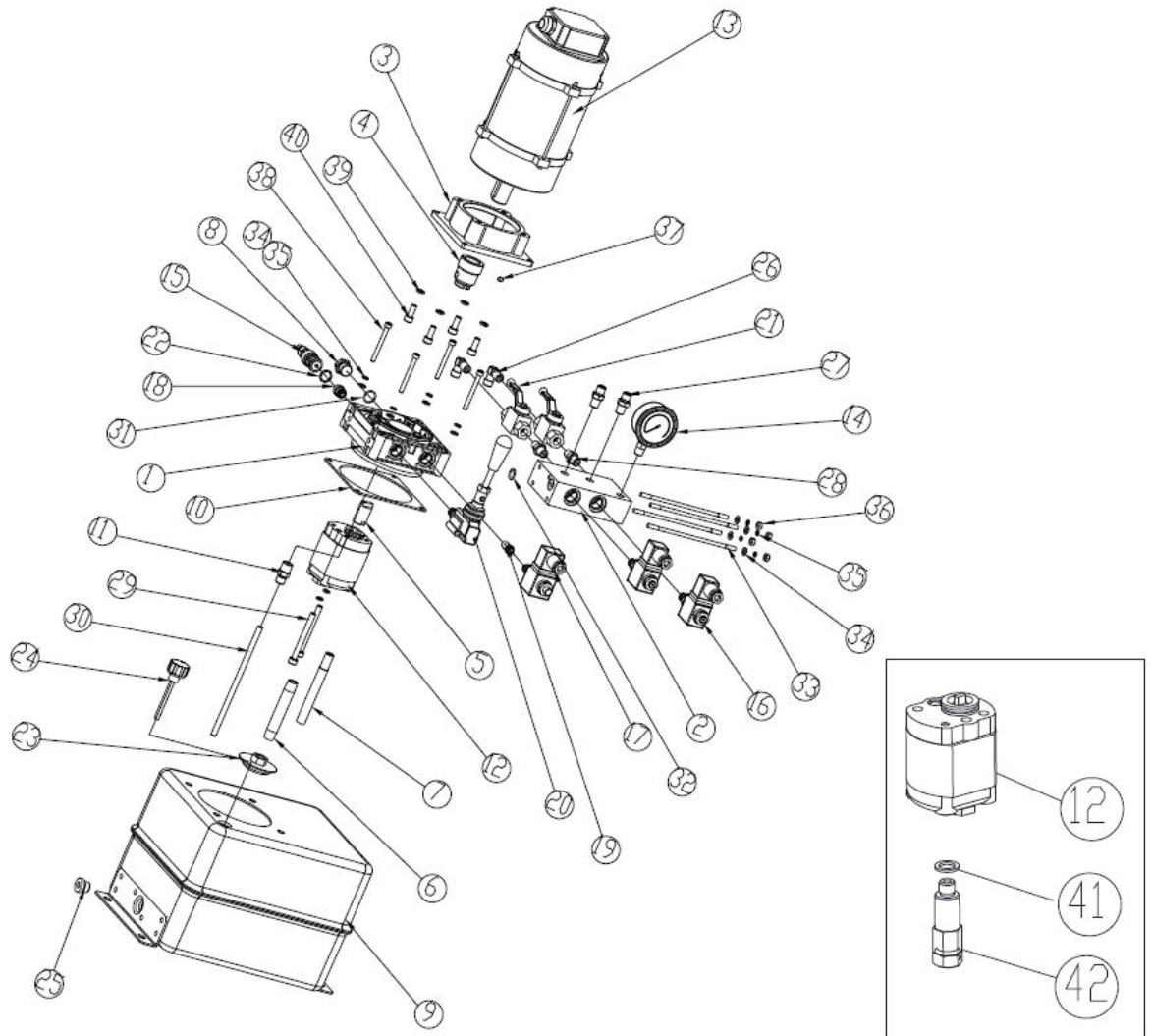

## Hydraulic Power Unit Parts List

Item	Part Num	Description	Qty
1	BZ-ZB-W4	Manifold	1
2	BZ-W-YK1	Interface block	1
3	BZ-DJ-1B	Motor flange	1
4	BZ-ZT24	Motor joint	1
5	BZ-BJ25	Pump joint	1
6	BZ-G18X110	Oil suction pipe	1
7	BZ-G14X200	Oil return pipe	1
8	BZ-SD-01	Manifold plug	1
9	HK2-0200	Oil tank	1



Item	Part Num	Description	Qty
10	BZ-F-01	Gasket	1
11	0306070	Rotation union 3/8	1
12	0301040	Gear pump 1.3CC	1
13	0509092	Motor 220V/60Hz/1PH 2.2kW	1
14	0305054	Pressure gauge 400bar 1/4	1
15	0307010	Pressure overload valve	1
16	0307043	Switching solenoid valve 220V	2
17	0307049	Lowering solenoid valve 220V	1
18	0307067	Non return valve	1
19	0307006	Lowering speed control valve D.2.5	1
20	0301034	Emergency hand pump	1
21	0307041	Leveling cutoff cock 1/4	2
22	0303057	Copper washer 16X20	1
23	0305010	Oil filter 3/8	1
24	0305026	Oil level plug 3/8	1
25	0305018	Tank plug 3/8	1
26	0303002	90° union 1/4	2
27	0303063	Union 1/4	2
28	0303060	Union 1/4	2
29	0202052	Screw M8X85 - GB/T70.1	2
30	0306097	Rilsan hose 8X5 L=190	1
31	0309054	O-ring 17.0X2.0	1
32	0309019	O-ring 18X2.4	1
33	0213032	Screw M6X160 - GB/T901	4
34	0205006	Washer D.6 - GB/T97.1	8
35	0208005	Locking washer D.6 - GB/T93	8
36	0203004	Nut M6 - GB/T6170	4
37	0209042	Screw M6X8 - GB/T80	1
38	0202036	Screw M6X65 - GB/T70.1	4
39	0208006	Locking washer D.8 - GB/T93	6
40	0202045	Screw M8X20 - GB/T70.1	4
41	0313001	Washer BS/A13.7	1
42	BZ-HC2-0	Starting valve for 1Ph (Optional)	1

# Jacking Beam Illustration

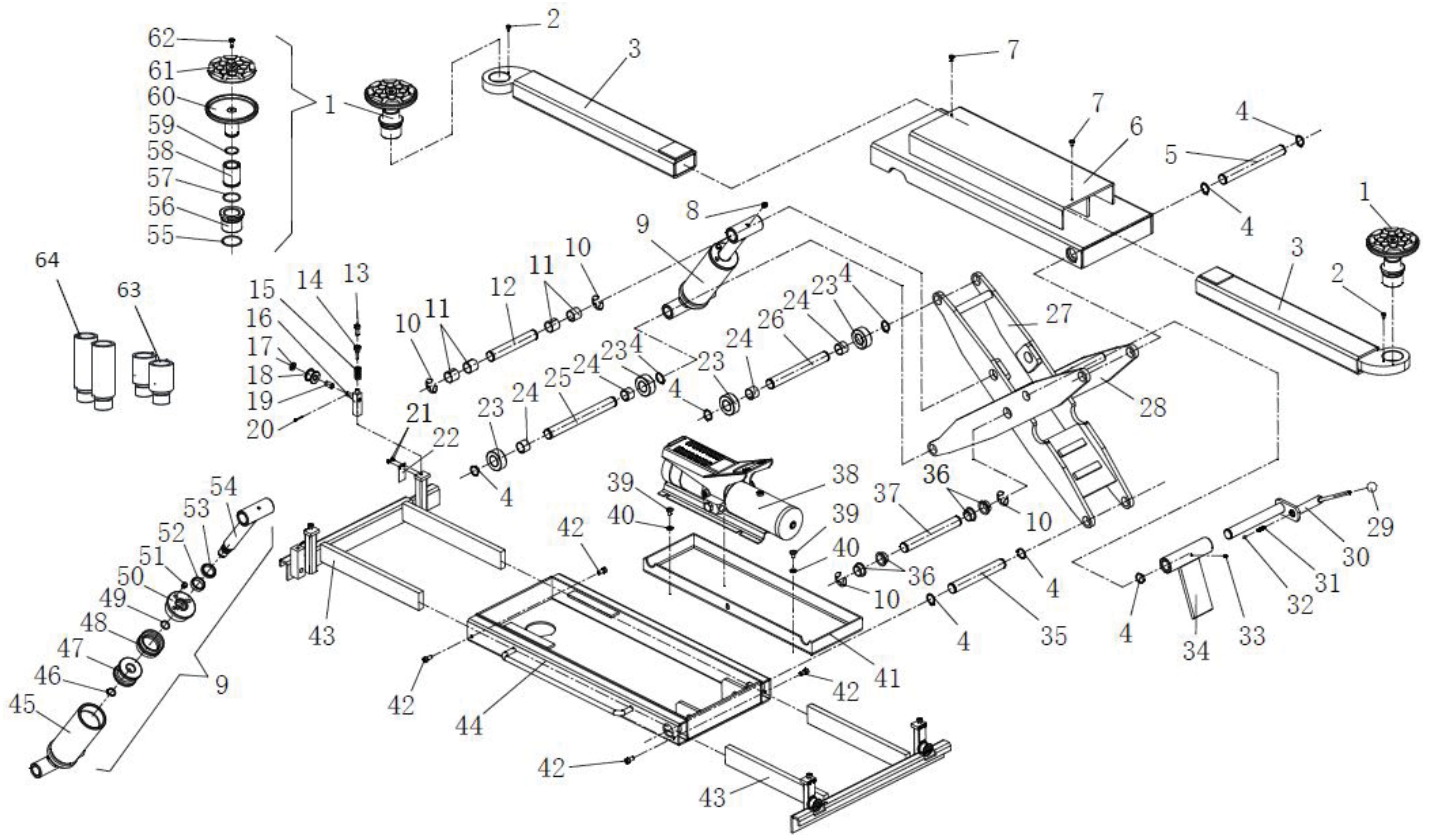

## Jacking Beam Parts List

Item	Part Num	Description	Qty
1	Z23A313000	Lifting adaptor assembly	2
2	0202020	Screw M5X8 - GB/T70.1	2
3	J07K220000	Lifting arm	2
4	0212004	Seeger D.25	9
5	HJ-RG-10-4	Shaft	1
6	J07K210000	Beam	1
7	0206031	Screw M6X10 - GB/T818	2
8	0215021	Greaser 8X1	1
9	HJ-63-0	Jack hydraulic cylinder unit	1
10	0211003	Seeger D.19	4
11	0210009	Bush SF-1/2525	4
12	HJ-RG-19	Cylinder upper shaft	1
13	0202045	Screw 8X20 - GB/T70.1	4

Item	Part Num	Description	Qty
14	J07K180001	Pin	4
15	HJ-RG-18	Spring	4
16	J07K130000	Slider	4
17	0205011	Washer D.10 - GB/T97.1	4
18	HJ-RG-14	Roller	4
19	0210001	Bush SF-1/1020	4
20	0213044	Split pin 2X20	4
21	0206019	Screw M4X6 - GB/T818	8
22	J07K180002	Anti-derailment plate	4
23	HJ-RG-11-1	Wheel	4
24	0210008	Bush SF-1/2520	4
25	HJ-RG-10-5	Cylinder lower shaft	1
26	HJ-RG-10-3	Shaft	1
27	J07K400000	Inner scissor arm	1
28	J07K300000	Outer scissor arm	1
29	0215016	Handle knob M8X25	1
30	HJ-RG-08-0	Safety release handle	1
31	HJ-SB-19-3	Spring	1
32	0215038	Steel ball D.8	1
33	0209010	Screw M6X10 - GB/T78	1
34	HJ-RG-09-0	Safety hook	1
35	HJ-RG-10-1	Shaft	1
36	0210066	Bush SF-1/2512F	4
37	HJ-RG-10-2	Central shaft	1
38	0301052	Air-hydraulic pedal pump 800CC	1
39	0206001	Screw M8X12 - GB/T818	2
40	0205008	Washer D.8 - GB/T97.1	2
41	6740A-61101A	Pump tray	1
42	0202040	Screw M8X16 - GB/T70.1	4
43	J07K120000	Base extension	2
44	J07Q110000	Jack base	1
45	HJ-63-1	Jack cylinder liner	1
46	0212005	Seeger D.20	1

Item	Part Num	Description	Qty
47	8240TX-63-2	Jack cylinder piston	1
48	0312012	Gasket 63X47X18.4	1
49	0309022	O-ring 24X2.4	1
50	8240TX-63-3	Cylinder guiding cover	1
51	0306087	Silencer 1/8	1
52	0305007	Guiding ring 30x10x2.5	1
53	0311005	Scraper 30X38X5/6.5	1
54	HJ-75-4	Cylinder shaft	1
55	0309091	O-ring 45X2.65	2
56	Z23A313002	Outer threaded bush	2
57	0212034	Seeger D.42	2
58	Z23A313001	Inner threaded bush	2
59	0212035	Seeger D.32	2
60	Z23A313100	Pad support	2
61	Z23A313202	Rubber pad	2
62	0202032	Screw M6X16 - GB/T70.1	2
63	Z23A601200	Adaptor extension H80 (For special request)	2
64	Z23A601300	Adaptor extension H155 (For special request)	2

# Hydraulic Line Illustration

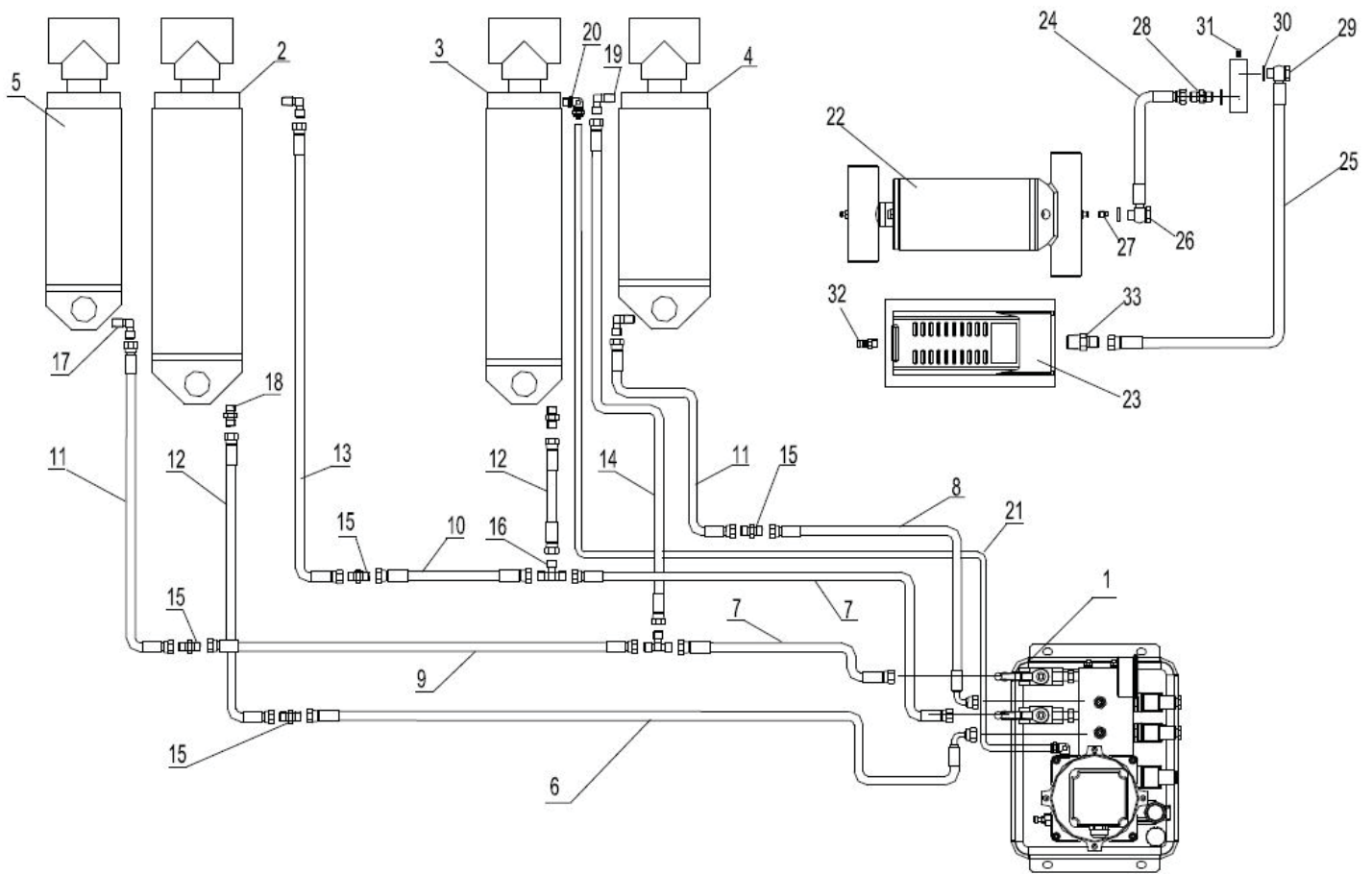

## Hydraulic Line Parts List

Item	Part Num	Description	Qty
1	BZ-W4K1Y	Hydraulic power unit	1
2	8250-120-00	Master hydraulic cylinder	1
3	8250-100-00	Slave hydraulic cylinder	1
4	8250-00C	Jack master hydraulic cylinder	1
5	8250-00D	Jack slave hydraulic cylinder	1
6	ZW5430	Hydraulic hose 1/4 L=5430	1
7	ZZ3600	Hydraulic hose 1/4 L=3600	2
8	ZW3700	Hydraulic hose 1/4 L=3700	1
9	ZZ1800	Hydraulic hose 1/4 L=1800	1
10	ZZ1400	Hydraulic hose 1/4 L=1400	1
11	ZZ5350	Hydraulic hose 1/4 L=5350	2

Item	Part Num	Description	Qty
12	ZZ370	Hydraulic hose 1/4 L=370	2
13	ZZ1200	Hydraulic hose 1/4 L=1200	1
14	ZZ5700	Hydraulic hose 1/4 L=5700	1
15	0303065	Union (1B-04)	4
16	0303021	Tee union (AB-04)	2
17	0303002	90 degree union (1BT9-04SP)	2
18	0303063	Union (1BT-04SP)	2
19	0303003	90 degree union (1BT9-04SP-Y)	2
20	0306067	Union (Φ10 ZG1/4)	1
21	0306109	PU hose (Φ10XΦ6.5X4900C)	1
22	HJ-63-0	Jack hydraulic cylinder	1
23	0301052	Air-hydraulic pedal pump 800CC	1
24	ZJ380	PU hydraulic hose L=380	1
25	ZJ700	Hydraulic hose L=700	1
26	BZ-720B-0401	Bolt	1
27	BZ-GZ-002	Screw	1
28	0303065	Union (1B-04)	1
29	0303027	Bolt (720B-04)	1
30	0313001	Washer (BS/A13.70)	6
31	0305001	Plug (ZBJ22 007-QD07)	1
32	0306112	Quick union (Φ8 G1-4)	1
33	0303064	Union 3/8 (1BT-04-06SP)	1

## Pneumatic Line Illustration

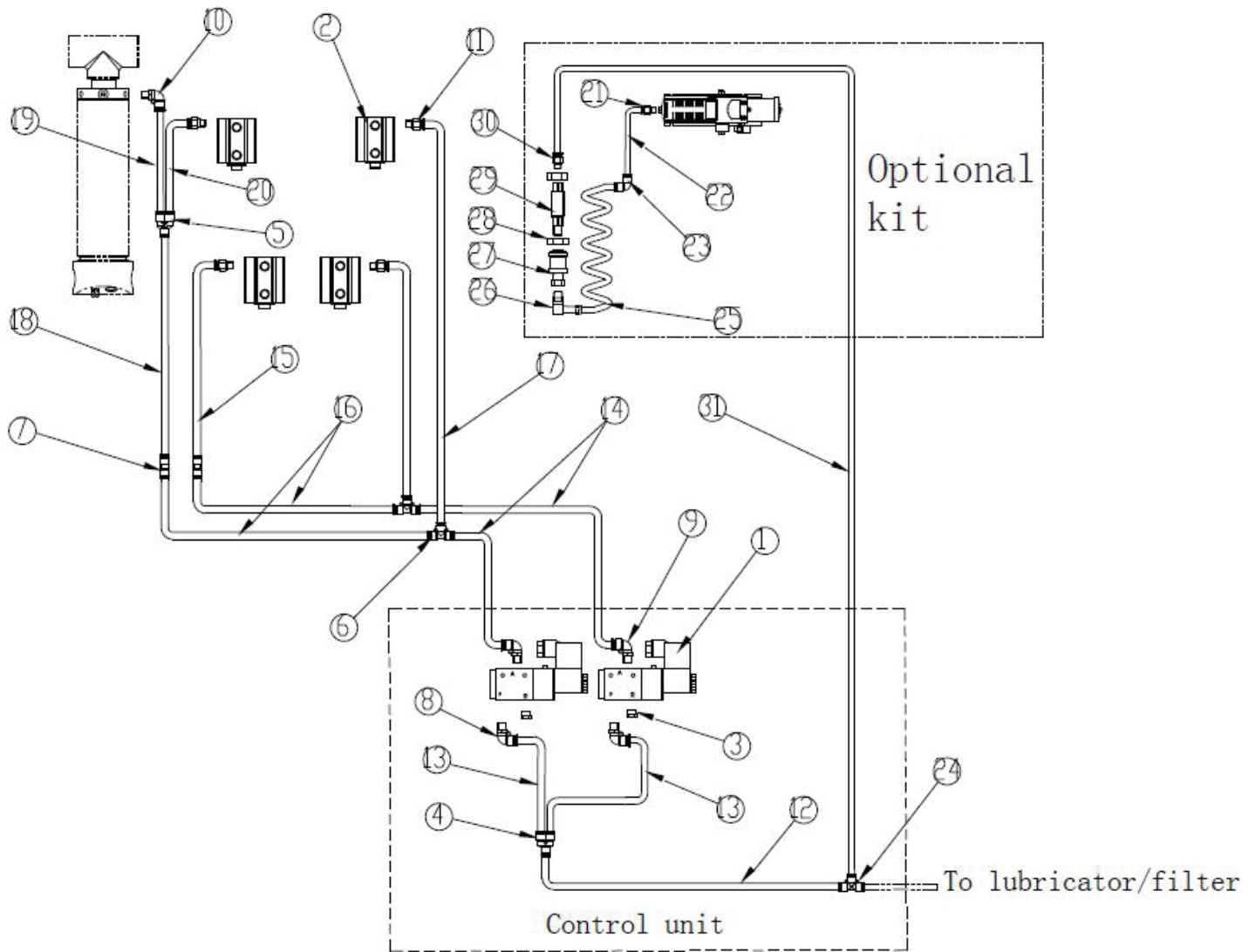

## Pneumatic Line Parts List

Item	Part Num	Description	Qty
1	0306177	Solenoid air valve G1/4 3V210-08 (220V)	2
2	0306010	Air safety release cylinder 32X23	4
3	0306086	Silencer 1/4	2
4	0306002	Y quick union 8	1
5	0306158	Y quick union 6	1
6	0306025	Tee quick union 6	2
7	0306041	Quick union 6	2
8	0306032	90 degree quick union 8-1/4	2
9	0306047	90 degree quick union 6-1/4	2



Item	Part Num	Description	Qty
10	0306040	90 degree quick union 6-1/8	1
11	0306046	Quick union 6-1/8	4
12	0306097	Rilsan hose 8X5 L=1000	1
13	0306097	Rilsan hose 8X5 L=120	2
14	0306095	Rilsan hose 6X4 L=4200	2
15	0306095	Rilsan hose 6X4 L=2600	2
16	0306095	Rilsan hose 6X4 L=2200	2
17	0306095	Rilsan hose 6X4 L=5500	1
18	0306095	Rilsan hose 6X4 L=5200	1
19	0306095	Rilsan hose 6X4 L=600	1
20	0306095	Rilsan hose 6X4 L=300	1
21	0306043	Quick union 6-1/4 (Optional)	1
22	0306095	Rilsan hose 6X4 L=850 (Optional)	1
23	0306121	90 degree quick union 6 (Optional)	1
24	0306022	Tee quick union 8 (Optional)	1
25	0306095	Spiral rilsan hose 6X4 L=4000 (Optional)	1
26	0306082	Rotation 90 degree union 6-1/4 (Optional)	1
27	0306192	Switching valve VMS-114 (Optional)	1
28	8250N61-810002G	Special nut (Optional)	2
29	8250N61-810001G	Union (Optional)	1
30	0306044	Quick union 8-1/4 (Optional)	1
31	0306097	Rilsan hose 8X5 L=12000 (Optional)	1



# Warranty

---



**This item** is warranted for two (2) years on structural components and one (1) year on air or electric hydraulic power units, pneumatic power units, cylinders and major components from date of invoice. Wear items are covered by a 90 day warranty.

This LIMITED warranty policy does **not include a labor** warranty.

**NOTE: ALL WARRANTY CLAIMS MUST BE PRE-APPROVED BY THE MANUFACTURER TO BE VALID.**

The Manufacturer shall repair or replace at their option for this period those parts returned to the factory freight prepaid, which prove after inspection to be defective. This warranty will not apply unless the product is installed, used and maintained in accordance with the Manufacturers installation, operation and maintenance instructions.

This warranty applies to the ORIGINAL purchaser only, and is non-transferable. The warranty covers the products to be free of defects in material and workmanship but, does not cover normal maintenance or adjustments, damage or malfunction caused by: improper handling, installation, abuse, misuse, negligence, carelessness of operation or normal wear and tear. In addition, this warranty does not cover equipment when repairs or alterations have been made or attempted to the Manufacturer's products.

THIS WARRANTY IS EXCLUSIVE AND IS LIEU OF ALL OTHER WARRANTIES EXPRESSED OR IMPLIED INCLUDING ANY IMPLIED WARRANTY OR MERCHANTABILITY OR ANY IMPLIED WARRANTY OF FITNESS FROM A PARTICULAR PURPOSE, AND ALL SUCH IMPLIED WARRANTIES ARE EXPRESSLY EXCLUDED.

THE REMEDIES DESCRIBED ARE EXCLUSIVE AND IN NO EVENT SHALL THE MANUFACTURER, NOR ANY SALES AGENT OR OTHER COMPANY AFFILIATED WITH IT OR THEM, BE LIABLE FOR SPECIAL CONSEQUENTIAL OR INCIDENTAL DAMAGES FOR THE BREACH OF OR DELAY IN PERFORMANCE OF THIS WARRANTY. THIS INCLUDES, BUT IS NOT LIMITED TO, LOSS OF PROFIT, RENTAL OR SUBSTITUTE EQUIPMENT OR OTHER COMMERCIAL LOSS.

**PRICES:** Prices and specifications are subject to change without notice. All orders will be invoiced at prices prevailing at time of shipment. Prices do not include any local, state or federal taxes.

**RETURNS:** Products may not be returned without prior written approval from the Manufacturer.

DUE TO THE COMPETITIVENESS OF THE SELLING PRICE OF THESE LIFTS, THIS WARRANTY POLICY WILL BE STRICTLY ADMINISTERED AND ADHERED TO.