

# INSTALLATION & OPERATION MANUAL



## Atlas 10-0HSC 10,000 lb. Capacity Two-Post Overhead Lift



**Atlas Automotive Equipment**  
[www.atlasautoequipment.com](http://www.atlasautoequipment.com)  
(866) 898-2604

**Read this entire manual before operation begins.**

Record below the following information which is located on the serial number data plate.

Serial No. \_\_\_\_\_

Model No. \_\_\_\_\_

Date of Installation \_\_\_\_\_

---

# Contents

---

Specifications . . . . .	4
Installation Requirement . . . . .	6
Steps Of Installation . . . . .	8
Exploded View . . . . .	26
Test Run . . . . .	30
Operation Instructions. . . . .	33
Maintenance Schedule. . . . .	34
Trouble Shooting . . . . .	35
10-OHSC Parts List . . . . .	36
Warranty . . . . .	42

---

# Specifications

## 10-OHSC Clearfloor Direct-Driven Model Features (See Fig.1)

- Direct-driving design, minimize the lift wear parts and breakdown ratio.
- Dual hydraulic direct-drive cylinders, designed and made on ANSI standard, utilizing oil seal in cylinder.
- Self-lubricating UHMW Polyethylene sliders and bronze bush.
- Single-point safety release, and dual safety design.
- Clearfloor design, provides unobstructed floor space.
- Overhead safety shut-off device.
- Super-symmetric arms design, make lifts easily find the lift point of the car.
- Stackable adapters 1.5", 2.5", 5" as standard.

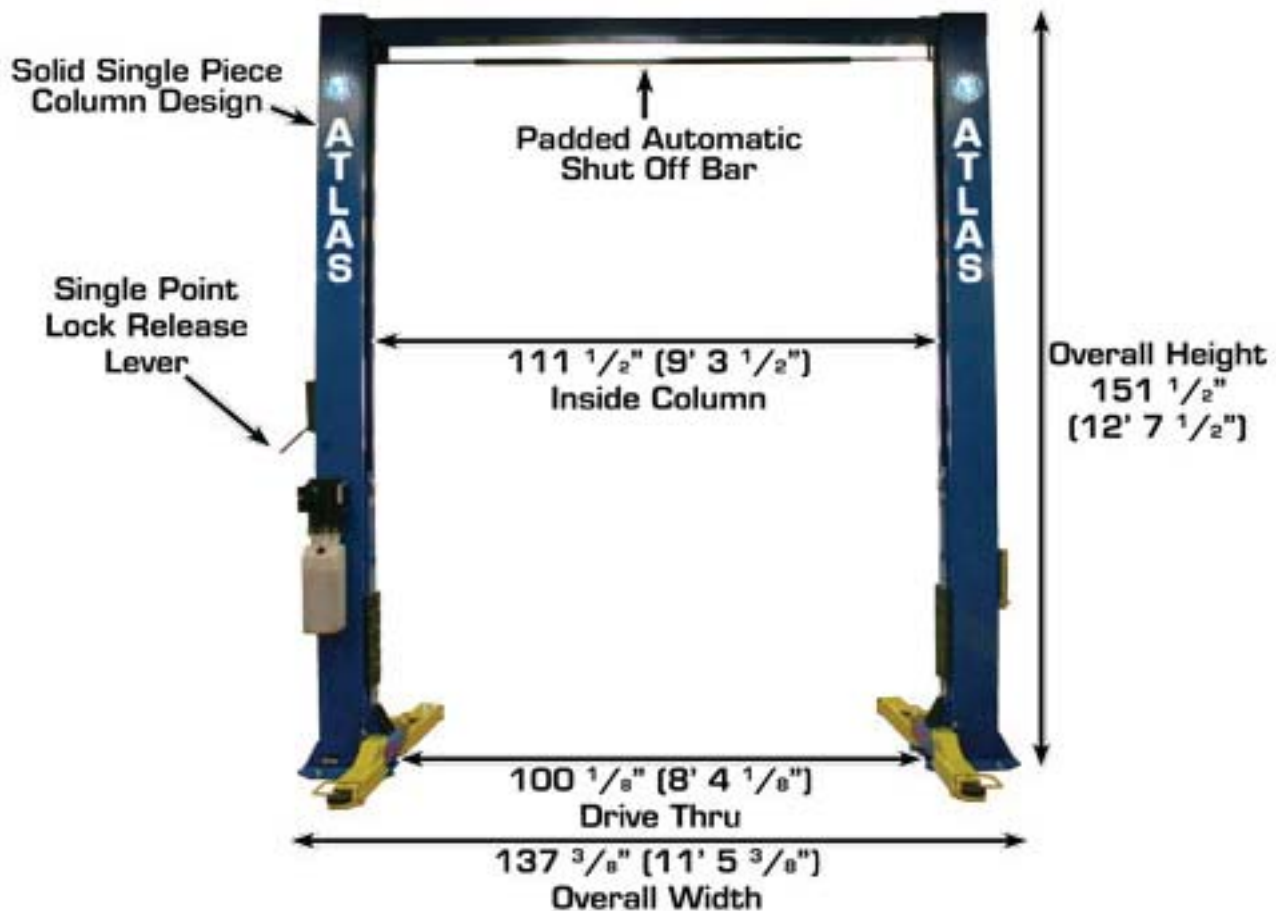


Fig. 1

# 10-OHSC Specifications

Model	Style	Lifting Capacity	Lifting Time	Lifting Height	Overall Height	Overall Width	Width Between Columns	Minimum Pad Height	Gross Weight	Motor
10-OHSC	Clearfloor Direct-drive	4.5 T 10,000lbs	60S	1940-2169mm 76 3/8"-85 3/8"	3854mm 151 3/4"	3516mm 138 3/8"	2850mm 112 1/4"	115mm 4 1/2"	780Kg 1,719lbs	2.0/3.0 HP

## Arm Swings View

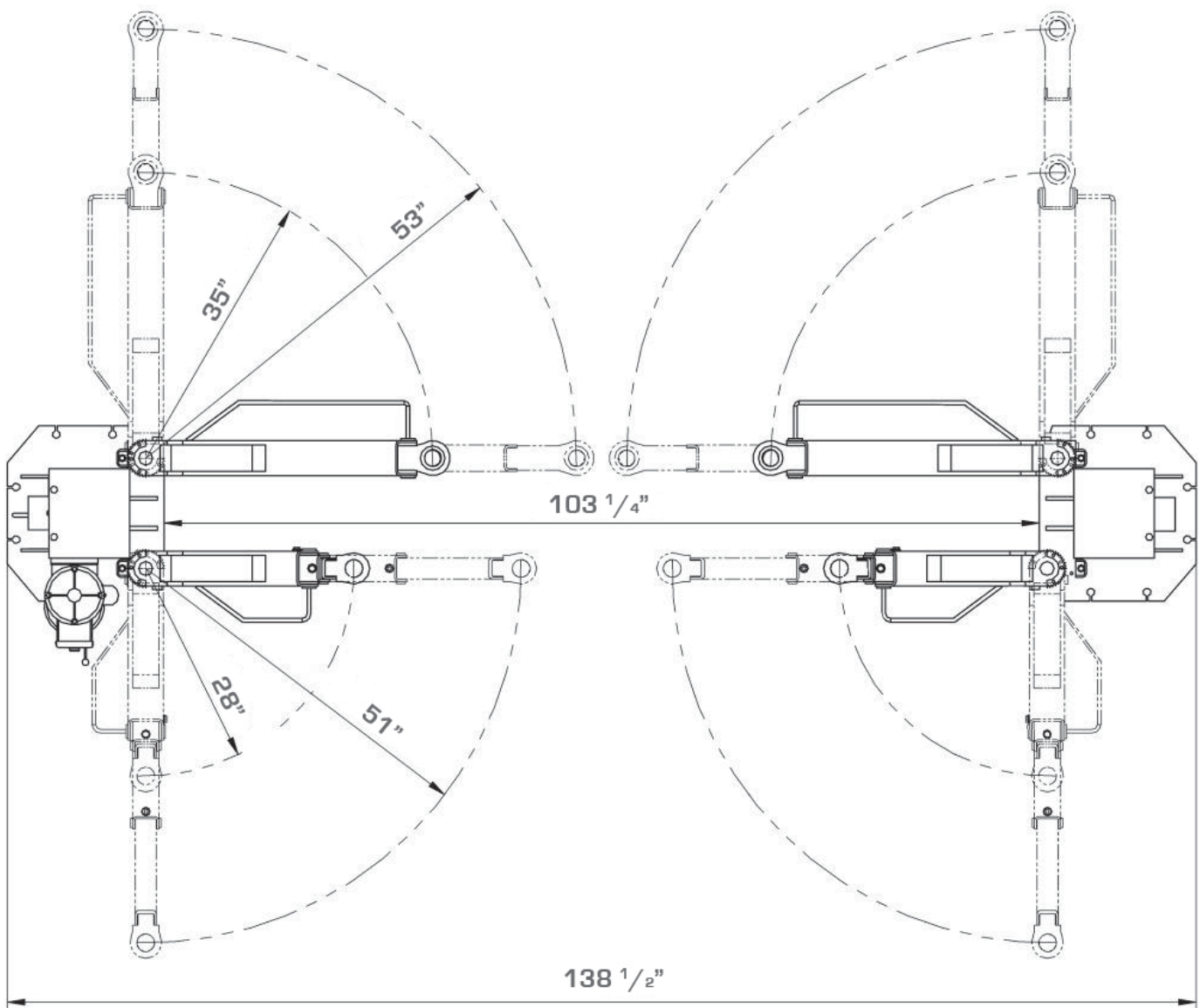


Fig. 2

# Installation Requirement

---

## Tools Required

Rotary Hammer Drill ( $\Phi 19$ )



Carpenter's Chalk



Hammer



Screw Drivers



Level Bar



Tape Measure (25ft)



Crescent Wrench (12")



Pliers



Ratchet Spanner With Socket (28#)



Allen Head Wrench (3#, 6#)



Wrench set  
(10#, 13#, 14#, 15#, 17#, 19#, 24#, 27#)



Vise Grips



Fig. 3

## Specifications Of Concrete (See Fig. 4)

Specifications of concrete must be adhered to the specification as following. Failure to do so may result in lift and/or vehicle falling.

1. Concrete must be thickness 4 inches minimum and without reinforcing steel bars, and must be dried totally before the installation.
2. Concrete must be in good condition and must be of test strength 3,000psi (210kg/cm<sup>2</sup>) minimum.
3. Floors must be level and no cracks.

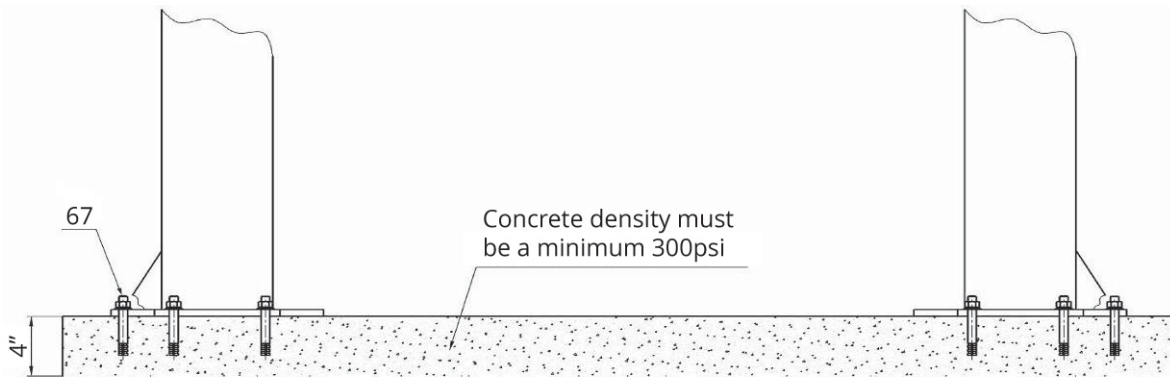


Fig. 4

## Power Supply

The electrical source must be 3HP minimum. The source cable size must be 2.5mm<sup>2</sup> and in good condition.

# Steps Of Installation

## A. Location of Installation

Check and insure the installation location (concrete, layout, space size etc.) is suitable for lift installation.

## B. Use a carpenter's chalk line to establish installation layout of baseplate (See Fig. 5).

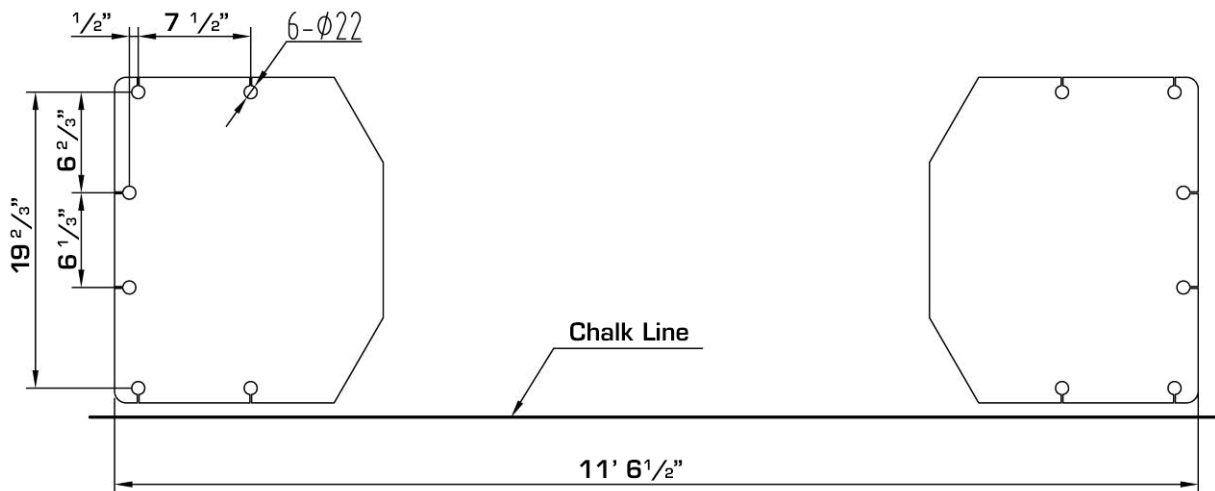


Fig. 5

## C. Check the parts before assembly

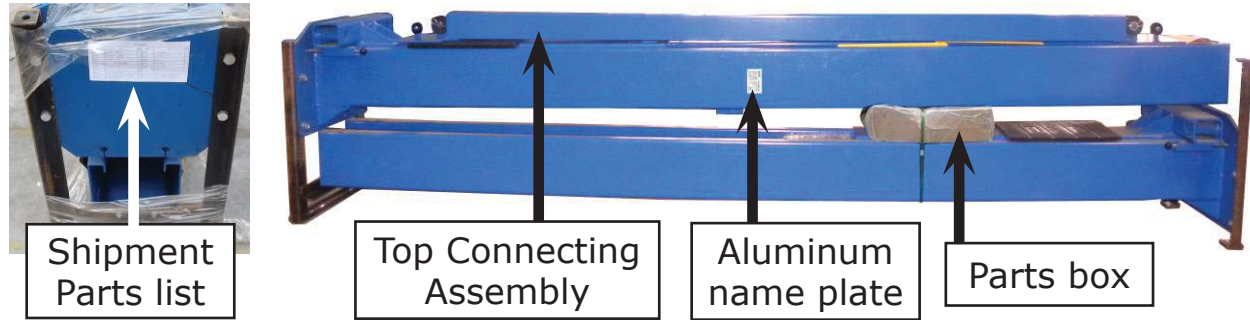
1. Packaged lift and hydraulic power unit (See Fig. 6)



Fig. 6

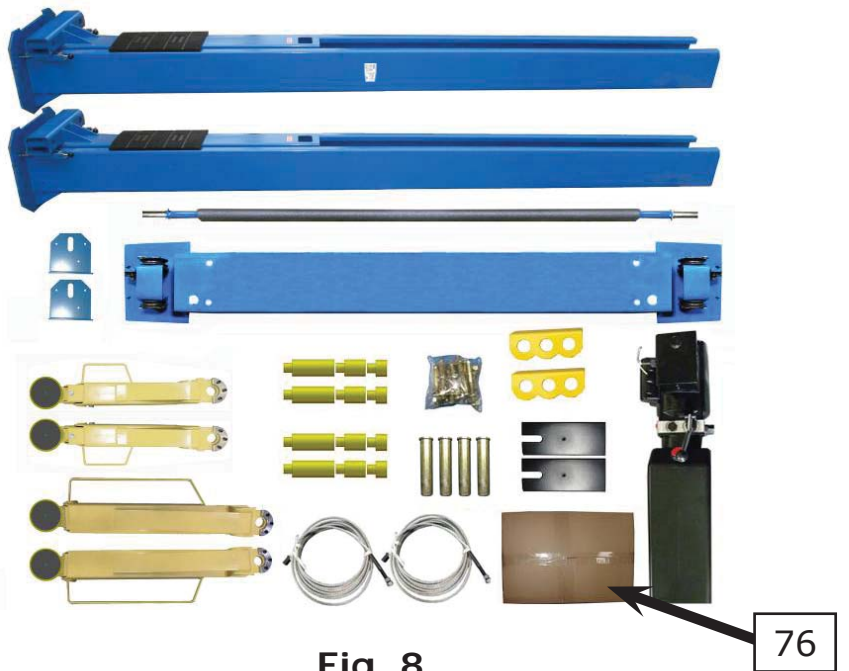


2. Move the lift aside with a fork lift or hoist, and open the outer packing carefully, take off the parts from upper and inside the column, take out the parts box, check the parts according to the shipment parts list (See Fig. 7).



**Fig. 7**

3. Loose the screws of the upper package stand, take off the upper column and remove the package stand.
4. Move aside the parts and check the parts according to the shipment parts list (See Fig. 8, 9).



**Fig. 8**  
Parts in the shipment parts list



**Fig. 9**  
Parts in the parts box (76)



## E. Connecting oil hose

Push the carriages, connecting the cylinder fittings and then connect the oil hose to the cylinder.

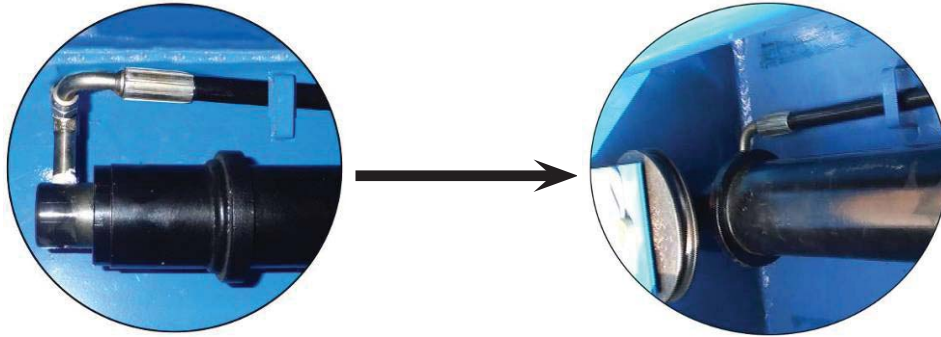


Fig. 12

## F. Connecting cables

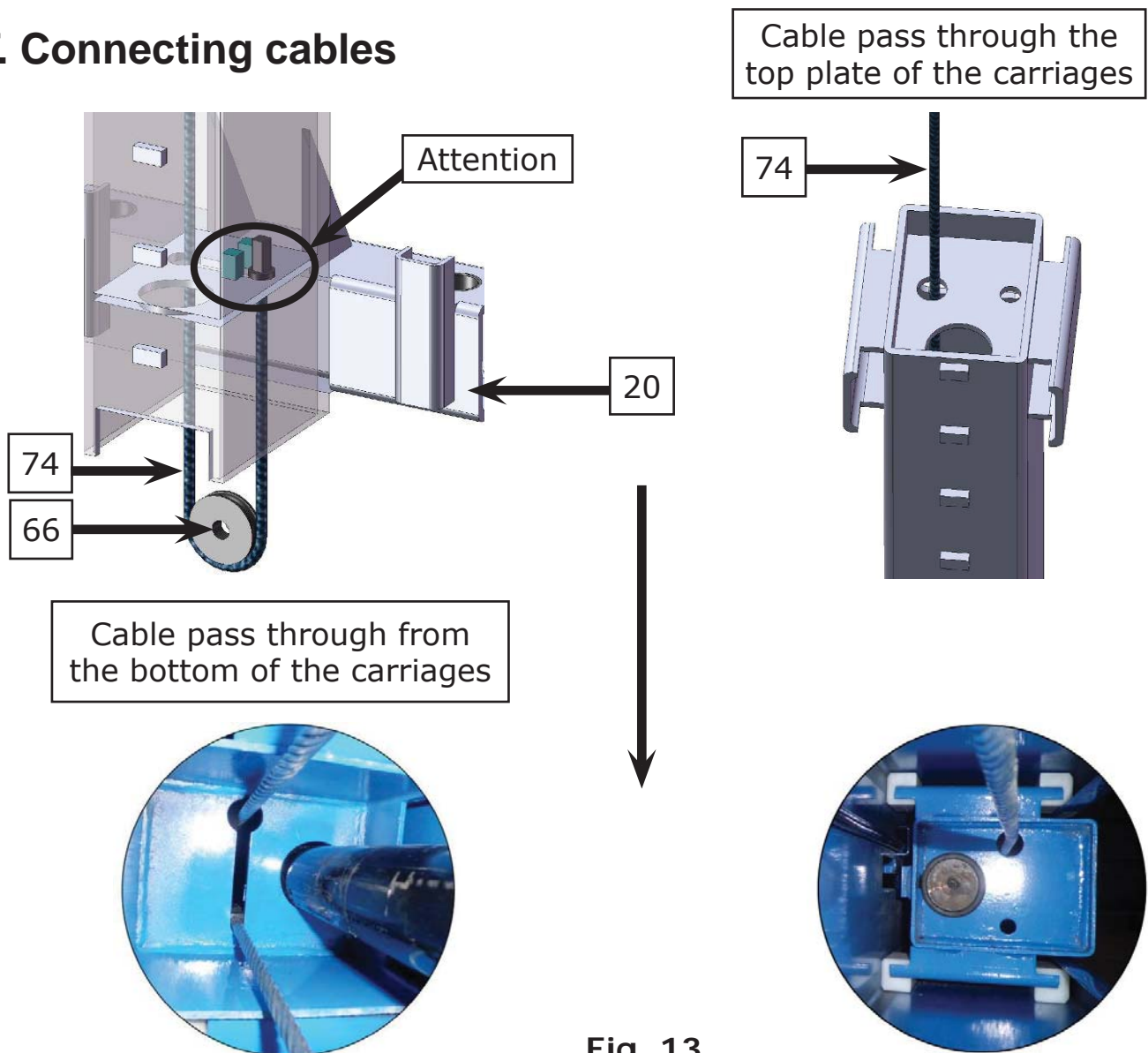


Fig. 13

## G. Lay the columns on their sides with cables and oil hoses installed, and with the open sides facing each other

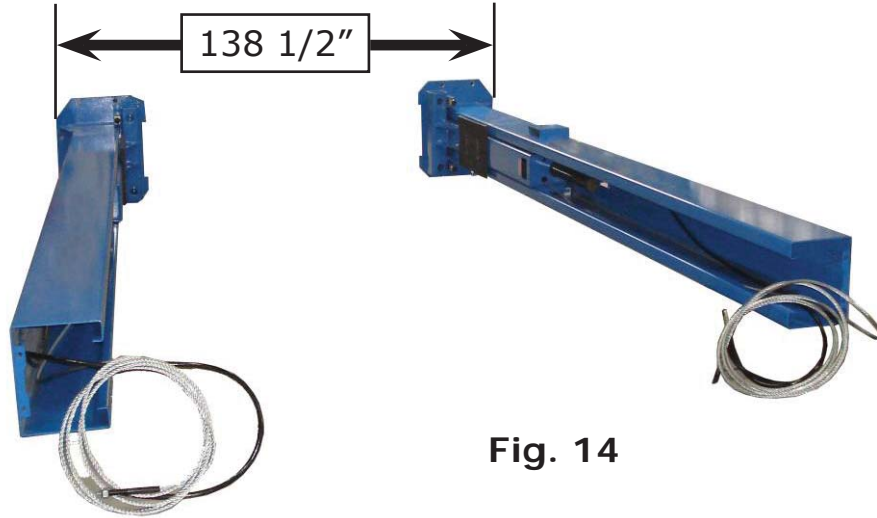


Fig. 14

## H. Position columns

Position the columns on the installation layout of baseplate. Install the anchor bolts. Do not tighten the anchor bolts (See Fig. 15).

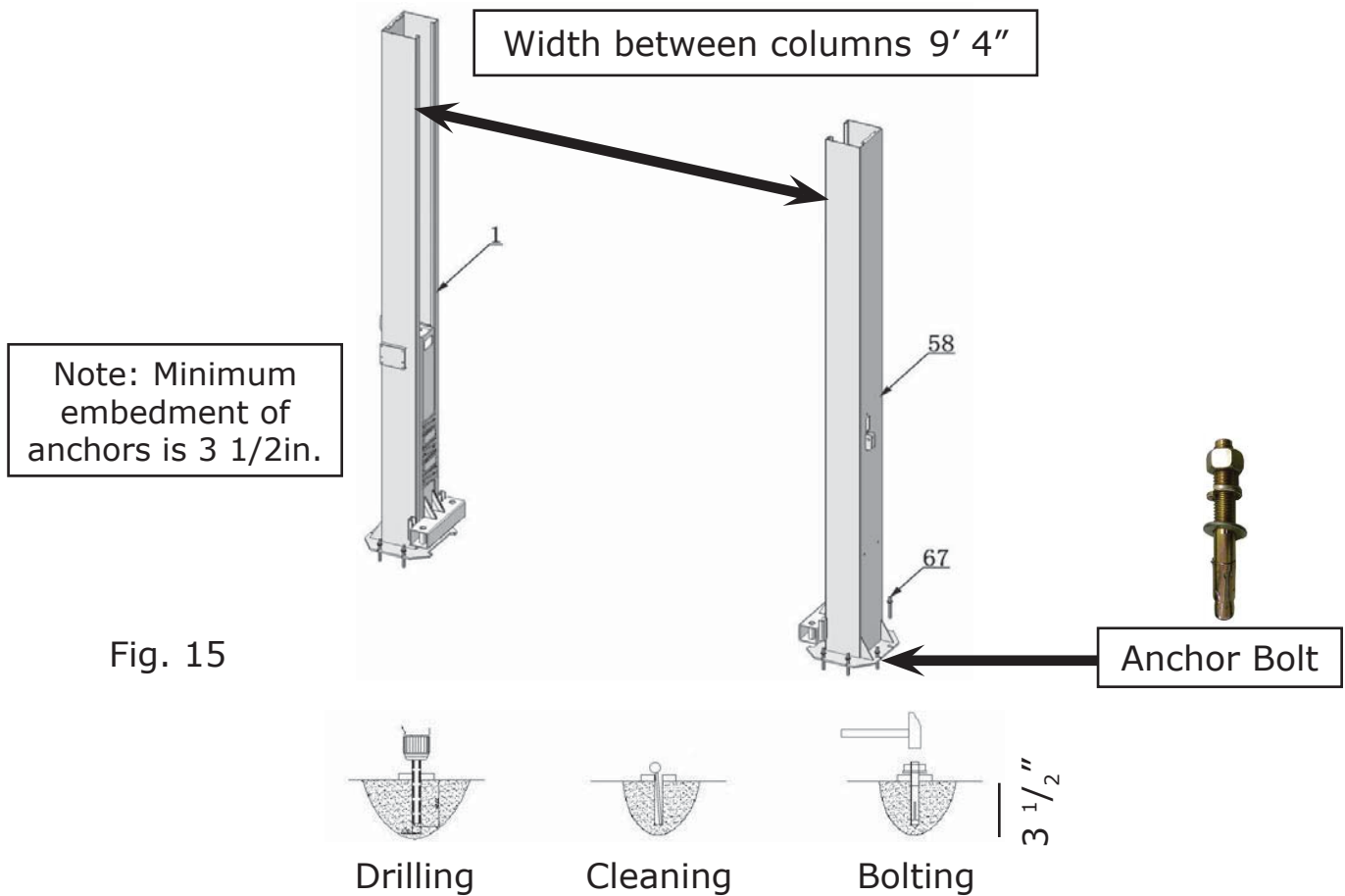


Fig. 15

**I. Assemble overhead top beams (See Fig.16).**



Fig. 16

**J. Check the columns plumbness with level bar, and adjusting with the shims if the columns are not vertical. Tighten the anchor bolts (See Fig.17).**

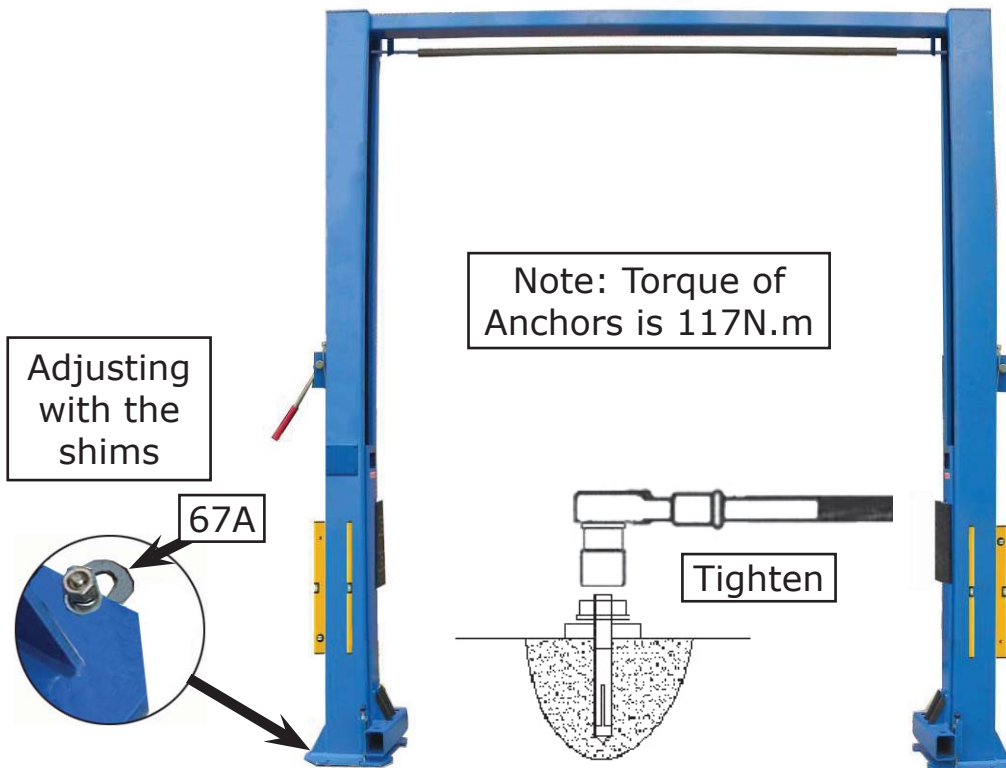
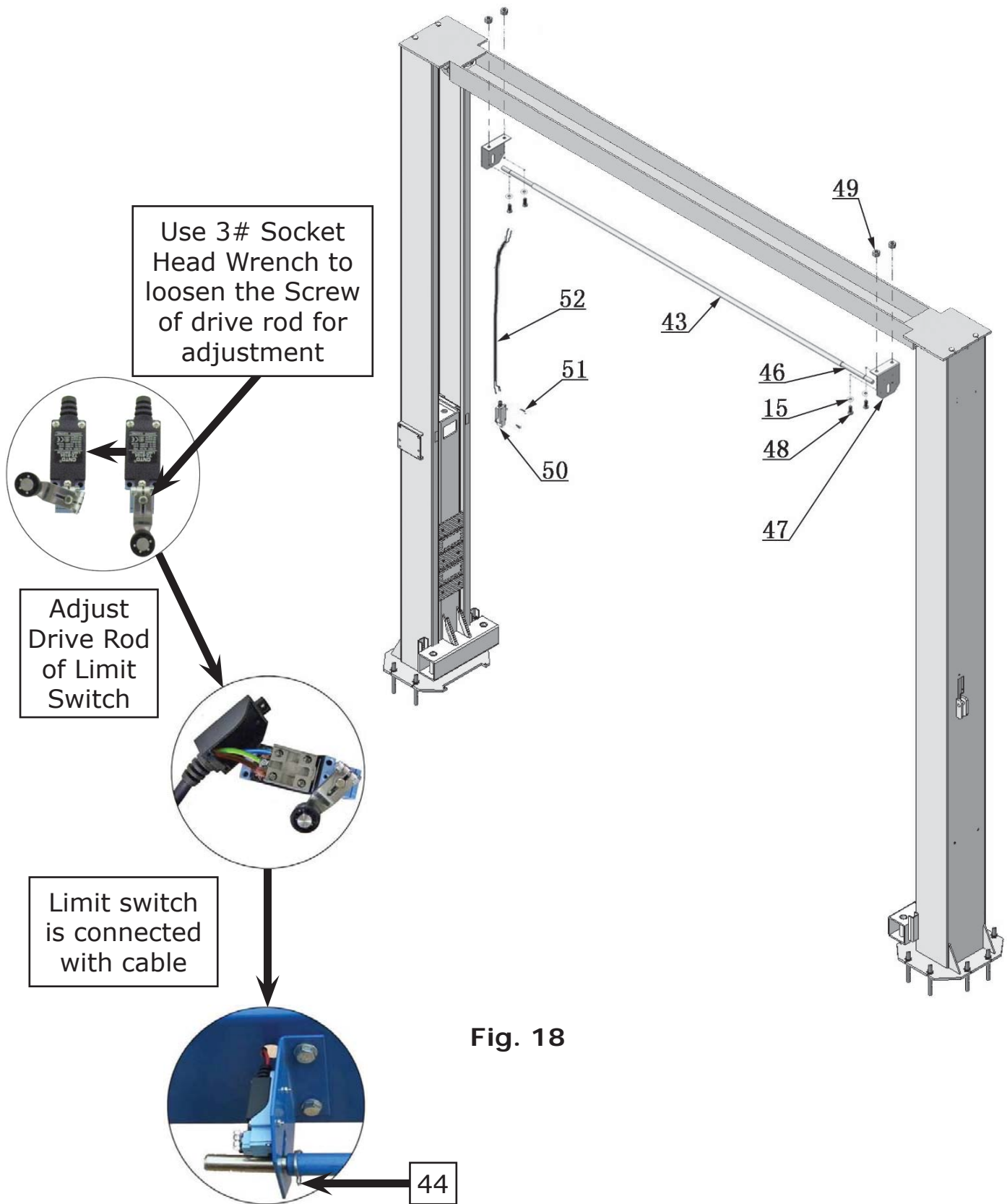


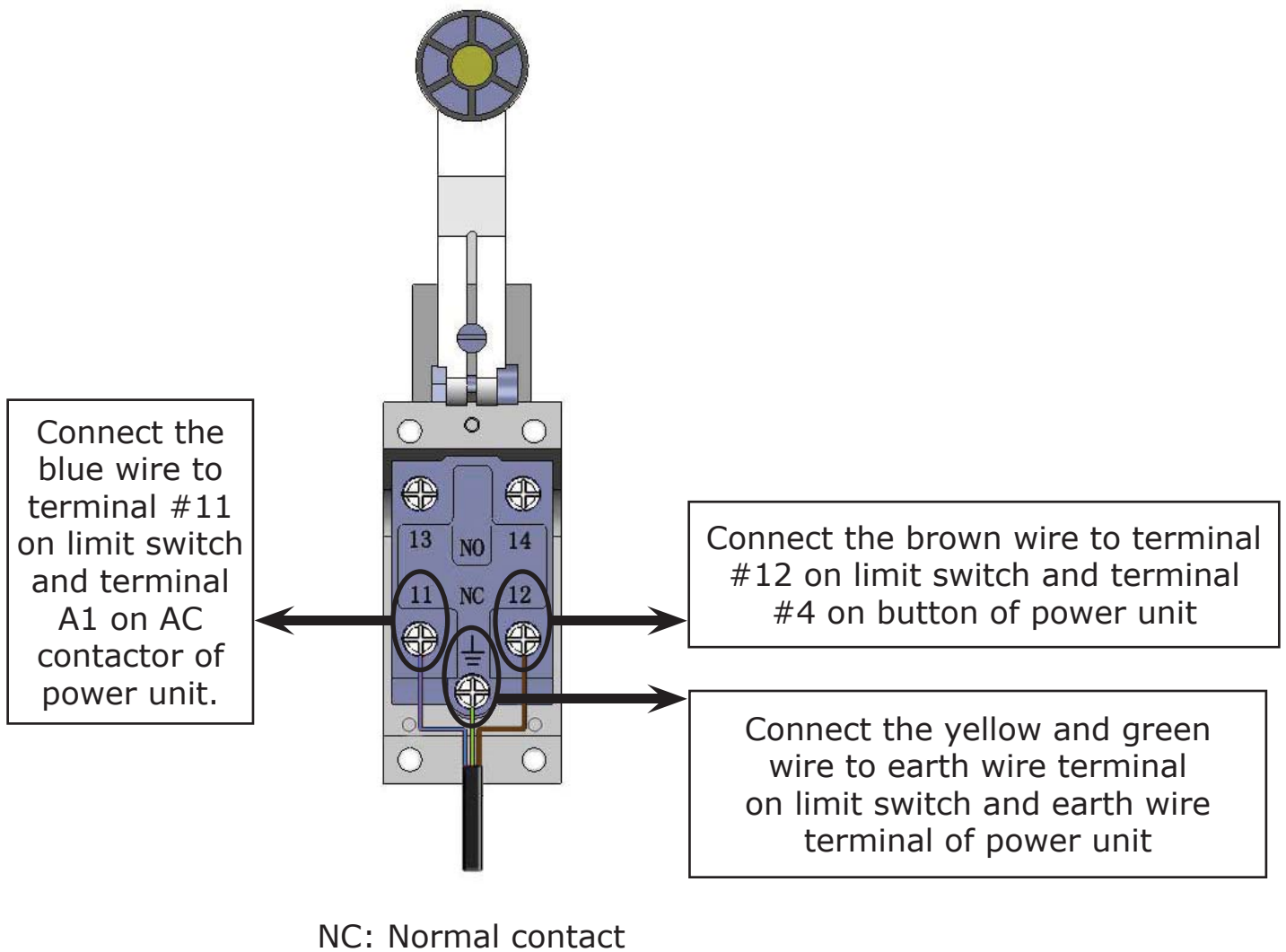
Fig. 17



**K. Install the limit switch control bar and limit switch (See Fig. 18).**

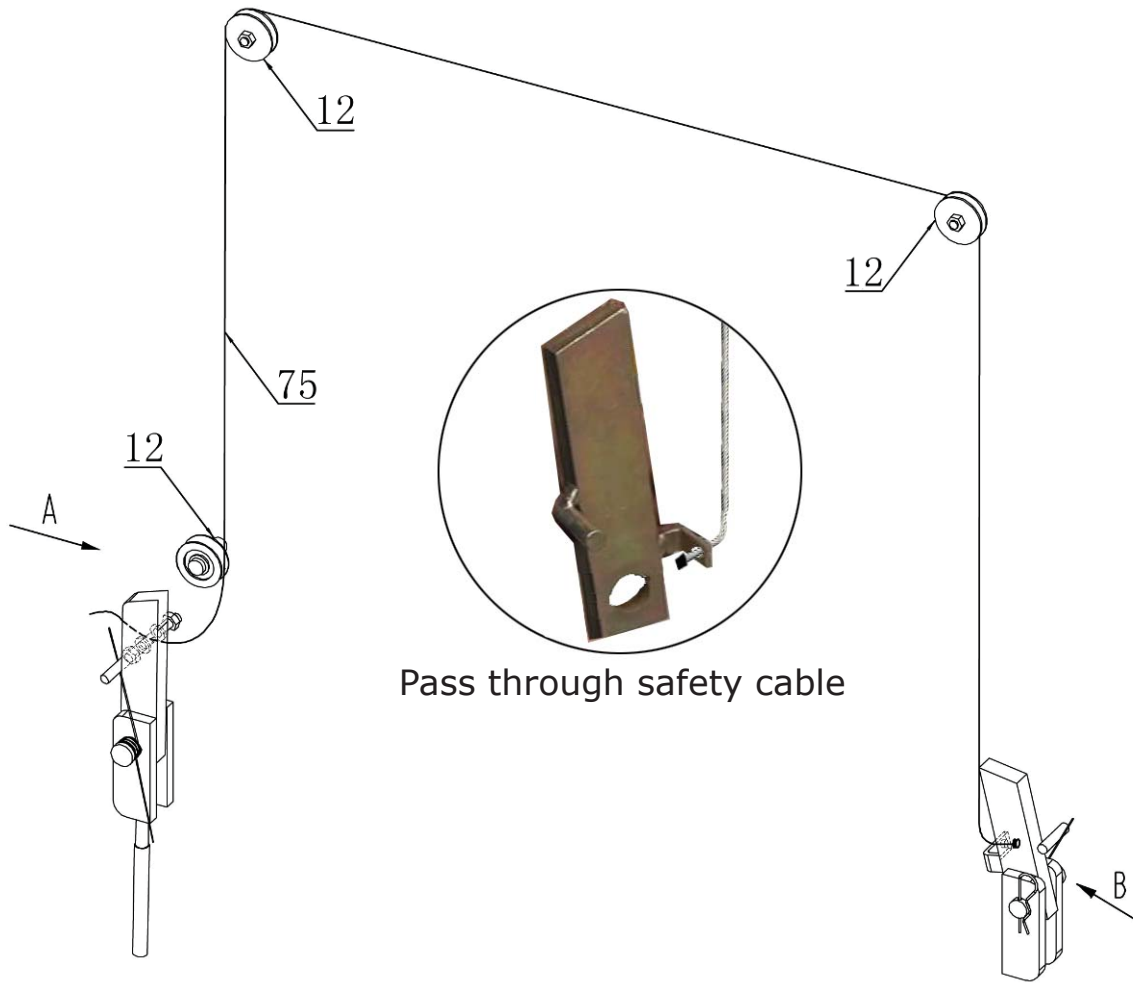


**Fig. 18**



**Fig. 18 (cont.)**

## L. Install safety cable (See Fig. 19).



View A

View B

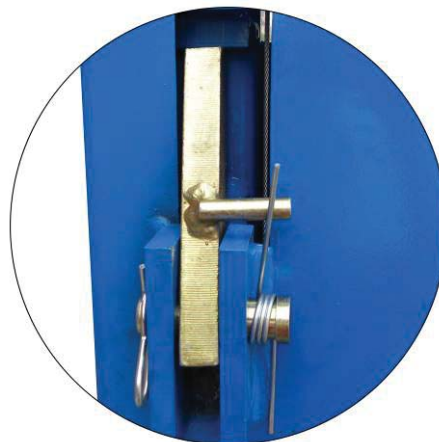


Fig. 19



## M. Install cables (See Fig. 20).

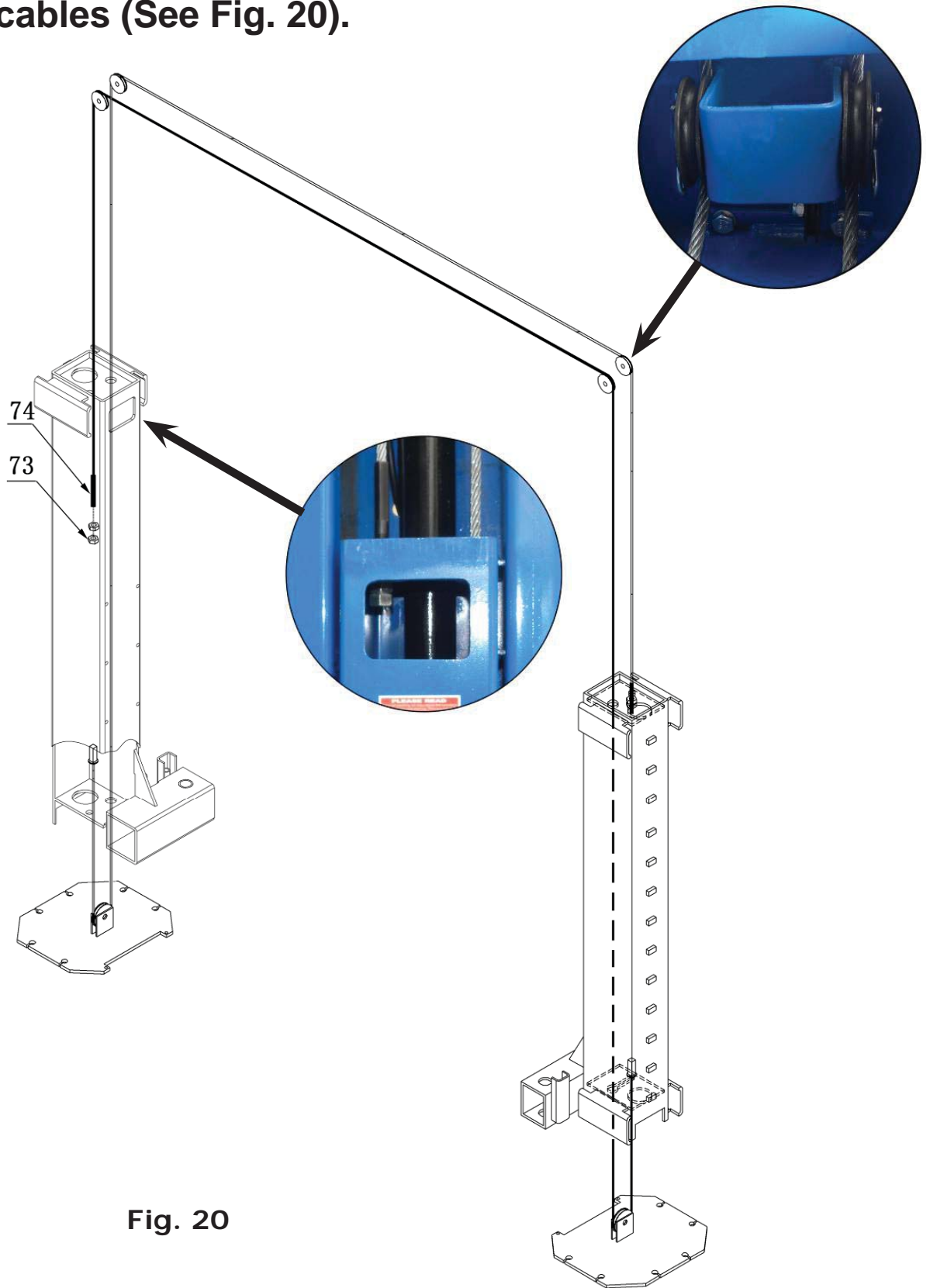


Fig. 20

# N. Assembly oil hose assembly (See Fig. 21).

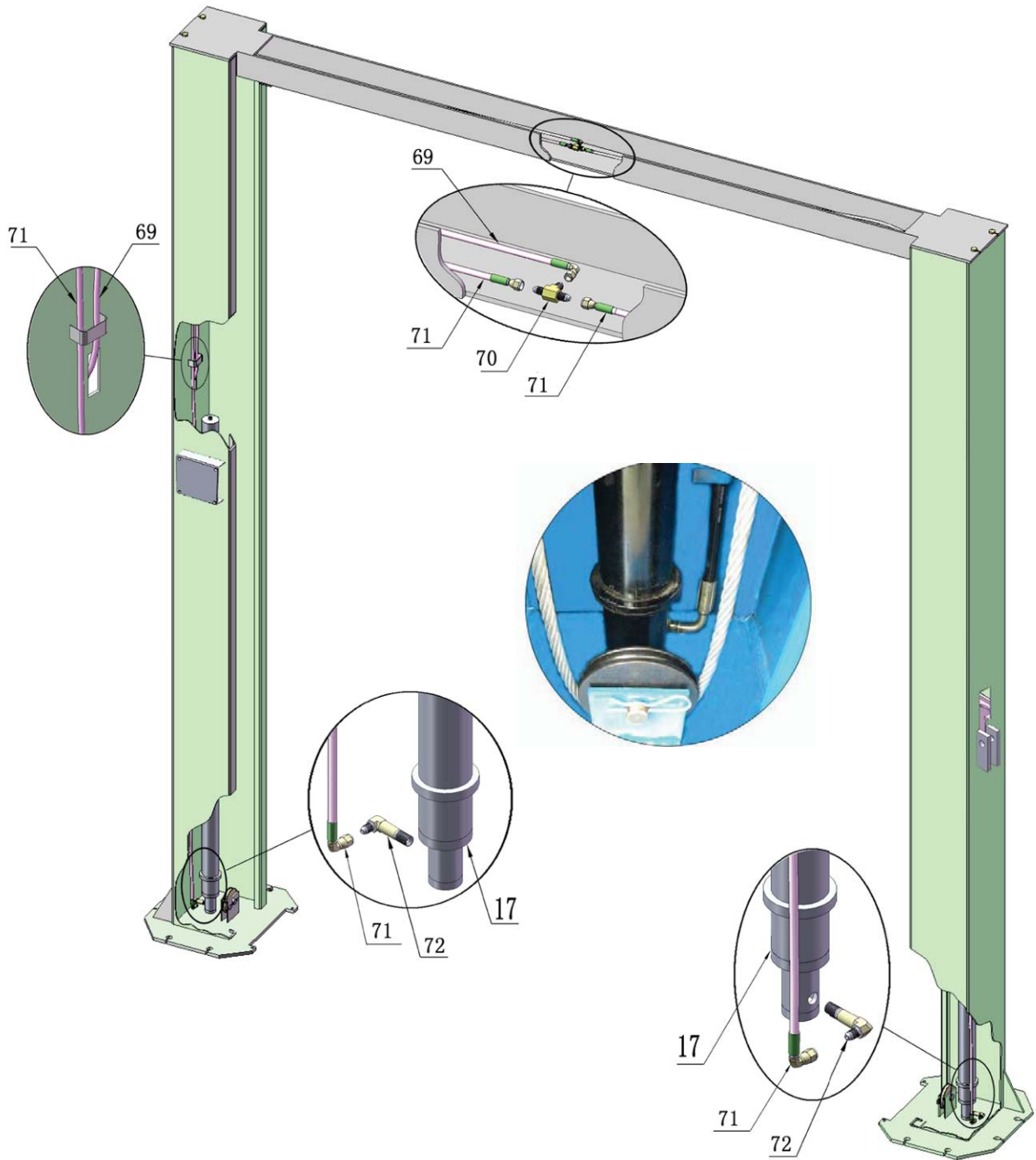


Fig. 21

## O. Install power unit and oil hoses (See Fig. 22)

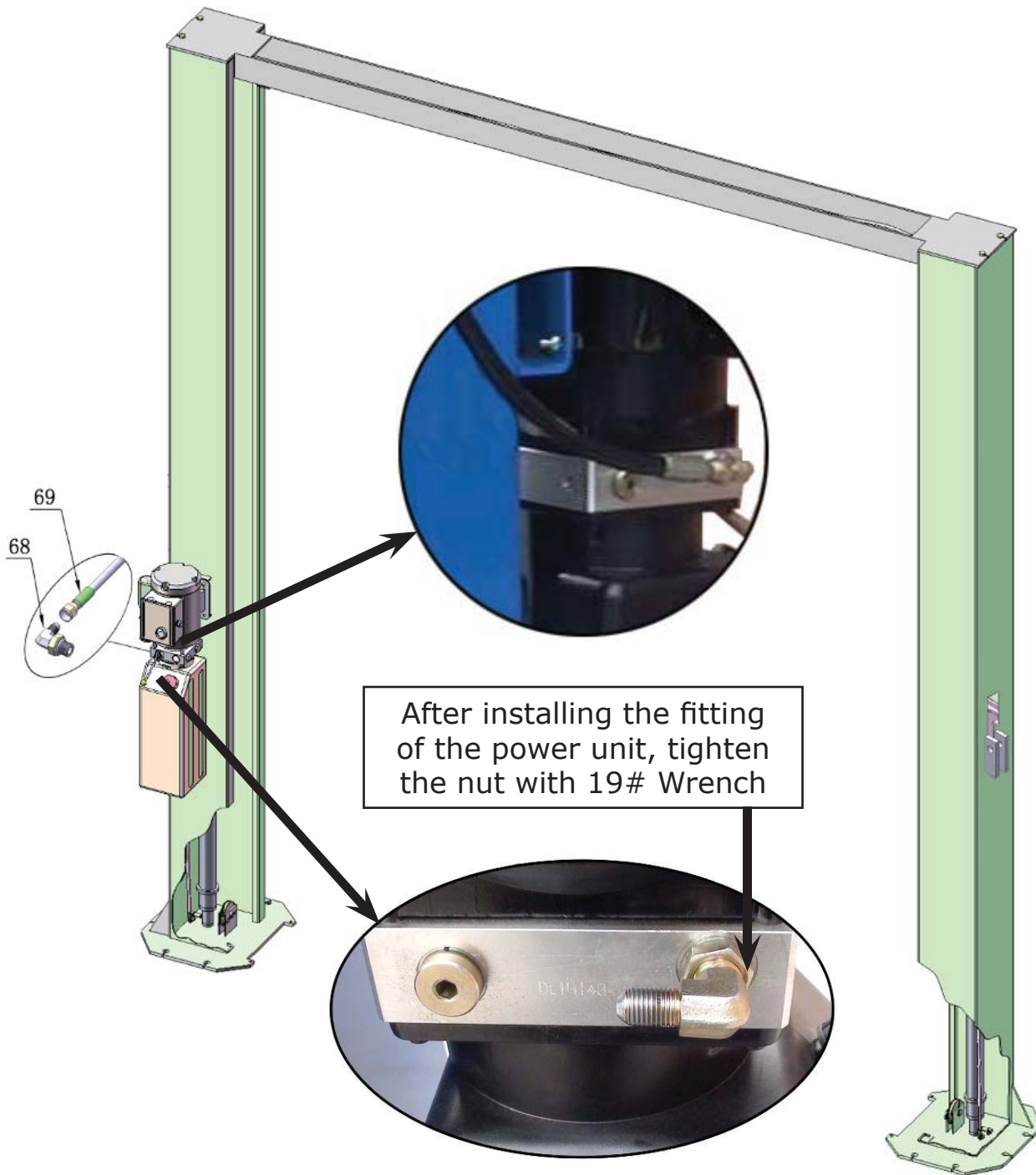


Fig. 22

Tighten all the hydraulic fittings, and fill the reservoir with hydraulic oil.

**Note:** In consideration of Hydraulic Power Unit's durability and keeping the equipment running in the perfect condition, please use Hydraulic Oil 46#.

## P. Install lifting arms and adjust the arm locks

1. Install the lifting arms (See Fig. 23).
2. Lowering the carriages down to the lowest position, then use the 17# wrench to loosen the nut of arm lock (See Fig. 24).

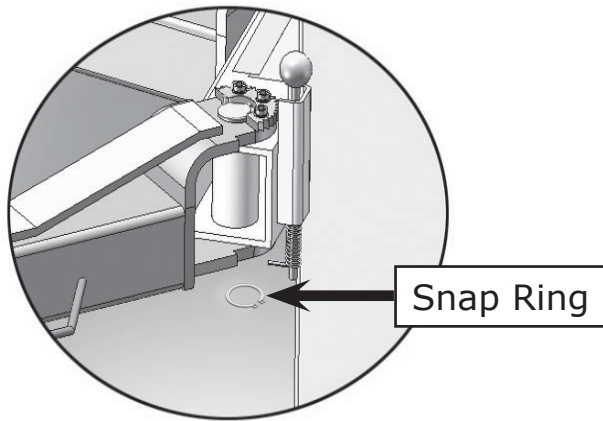


Fig. 23

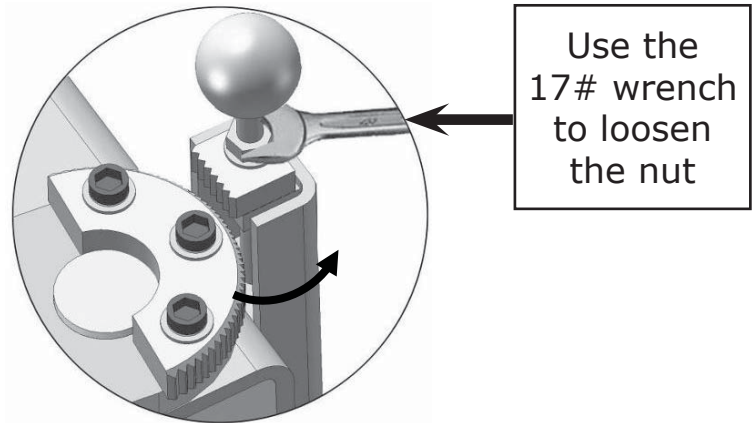


Fig. 24

3. Adjust the arm lock as direction of arrow (See Fig. 25)
4. Adjust the moon gear and arm lock to make it to be meshed, then tighten the nut of arm lock (See Fig. 26).

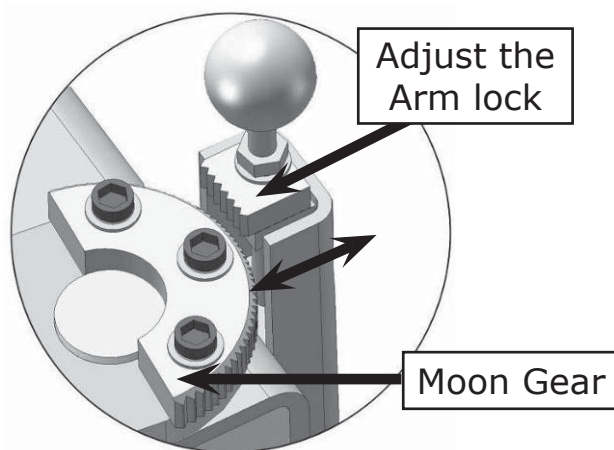


Fig. 25

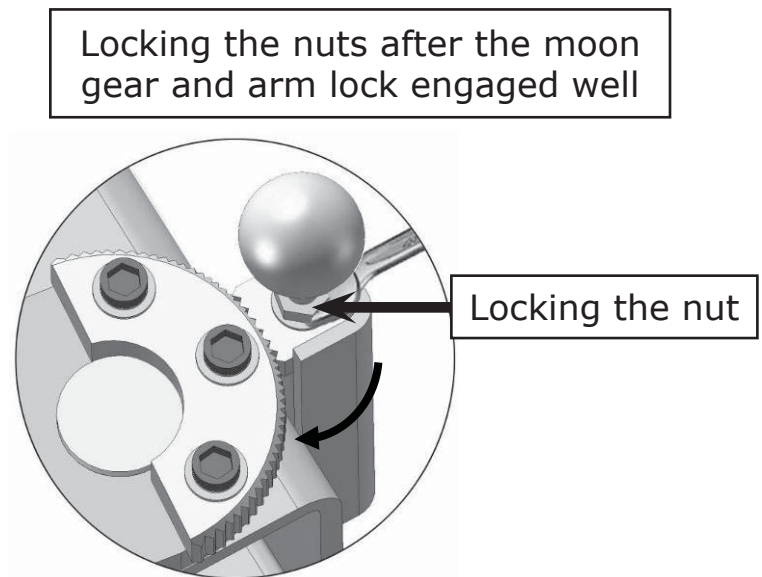


Fig. 26

## Q. Install electrical system

Connect the power source on the data plate of power unit.

**Note: 1. For the safety of operators, the power wiring must contact the floor well.**

### Atlas single phase motor (See Fig. 27).

1. Connecting the two power supply lines (Active **L** and Neutral wire **N**) to terminals of AC contactor marked **L1**, **L2** respectively.
2. Connecting the two motor wires to terminals of AC contactor marked **T1**, **T2**.
3. Connecting **A2** to **L2** of AC contactor.
4. Connecting the Limit Switch: Removing the wire of connecting terminal 4# on control button and terminal **A1** on AC contactor firstly (See Fig. 28), then connecting wire 12# (brown color) of the limit switch with terminal 4# of the control button and connecting wire 11# (blue color) with terminal **A1** on AC contactor respectively. Connecting the earth wire (green and yellow color) of the limit switch with earth wire terminal on power unit. (See Fig. 29).
5. Connecting terminal 3# on control button with terminal **L1** of AC contactor.

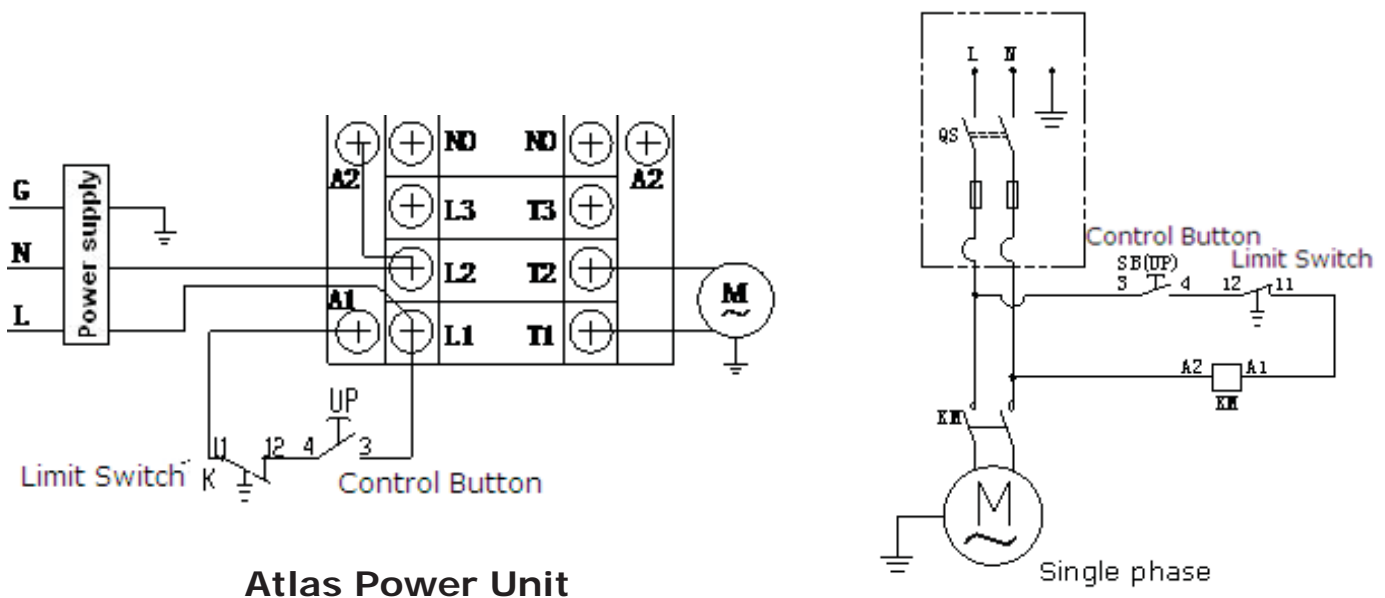


Fig. 27

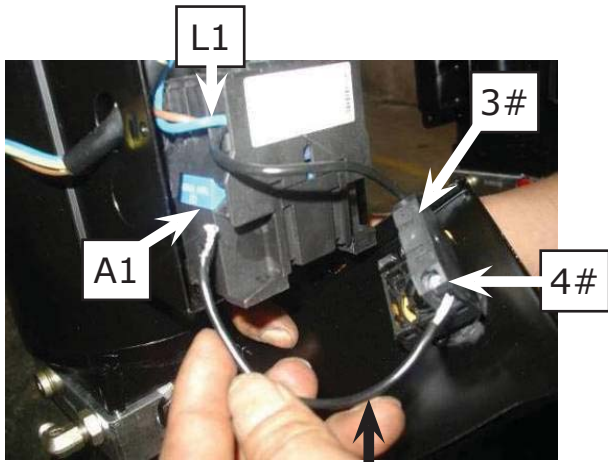


Fig. 28

Remove this wire  
before connecting  
the Limit Switch

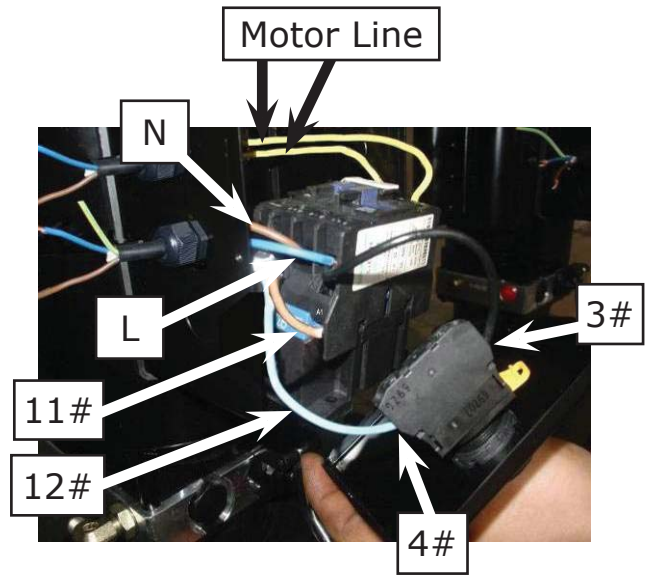


Fig. 29



## SPX single phase motor (See Fig. 30)

1. Power supply line (Neutral wire **N**) connected with wire **5#** of motor.
2. Wire **11# (blue wire)** of limit switch is connected with wire **6#** of motor.
3. Wire **12# (brown wire)** of limit switch is connected with wire **4#** of control button.
4. Earth wire (yellow and green wire) of limit switch is connected with terminal earth wire of power unit.
5. Wire **3#** on control button is connected with active wire(L) of the power supply.

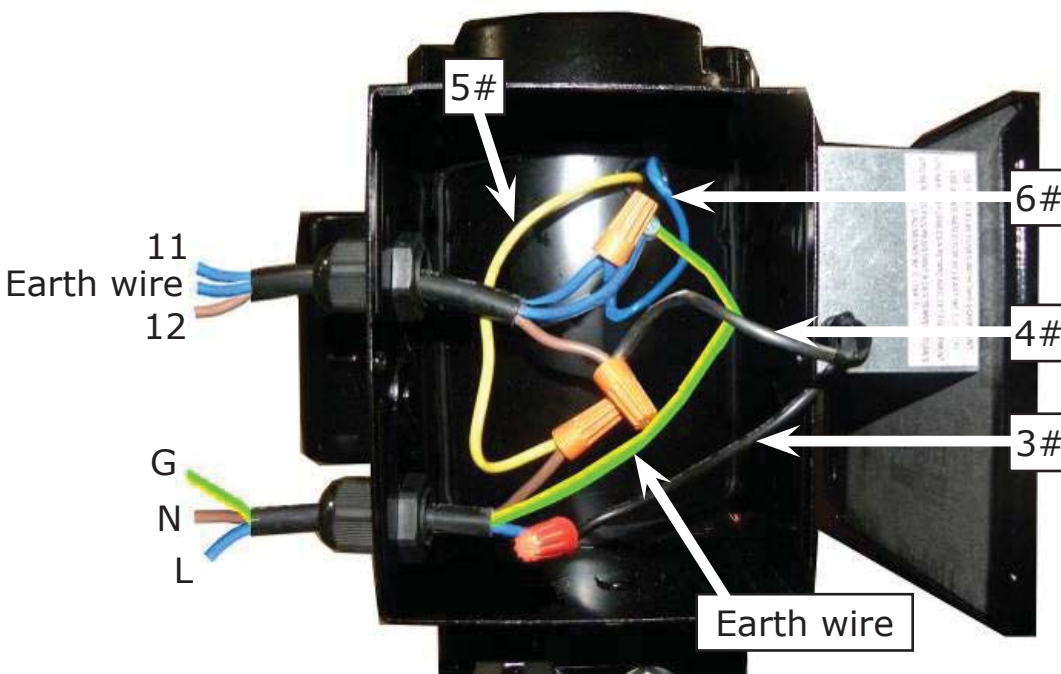
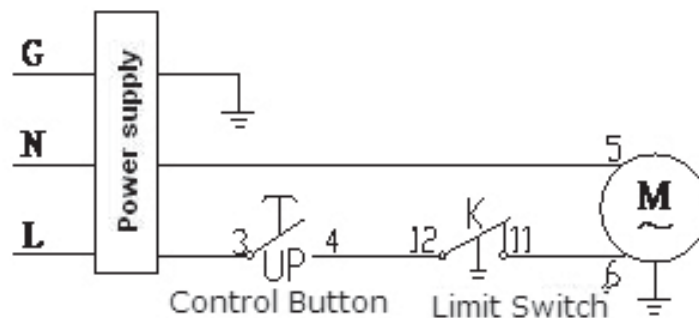
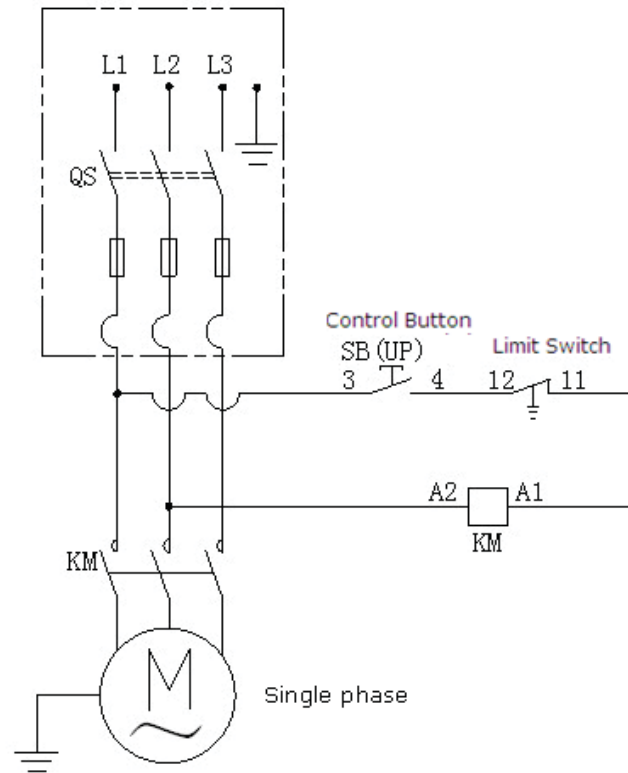


Fig. 30

## Three phase motor

### 1. Circuit diagram (See Fig. 31)



**Fig. 31**



## 2. Connection step (See Fig. 32)

- The source wires (**L1, L2, L3**) connected with terminals of AC contactor marked **L1, L2, L3** respectively.
- Terminals **4#** of control button connected with wire **12#** (brown wire) of limit switch; wire **11#** (blue wire) connected with **A1** terminals of AC contactor, Earth wire (yellow and green wire) of limit switch is connected with terminal earth wire of the motor.
- Terminals **3#** of control button connected with **L1** terminals of AC contactor.

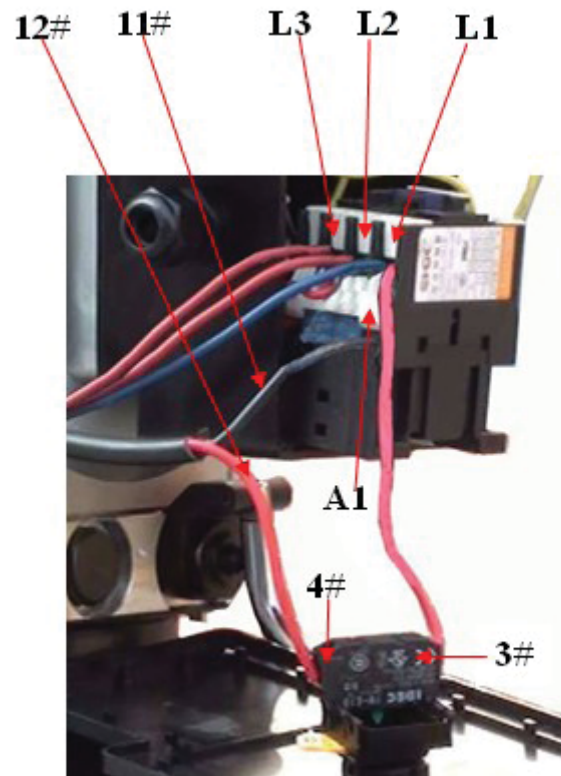
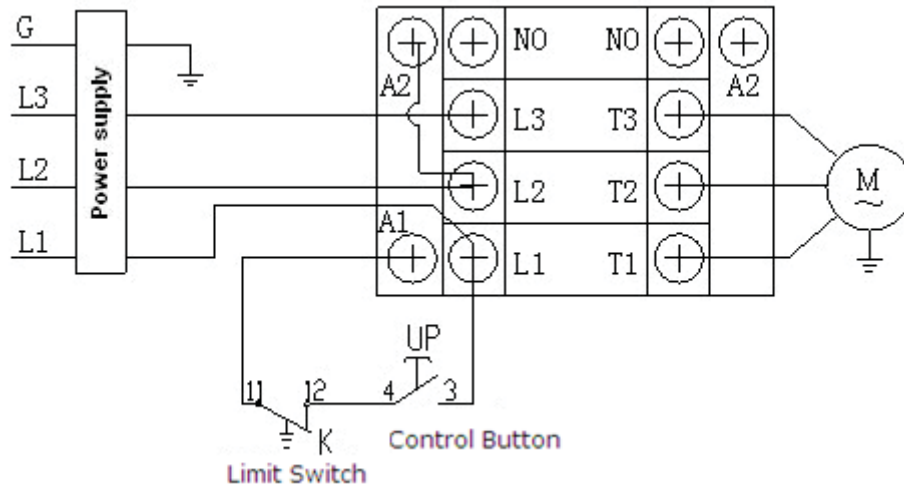


Fig. 32

# Exploded View

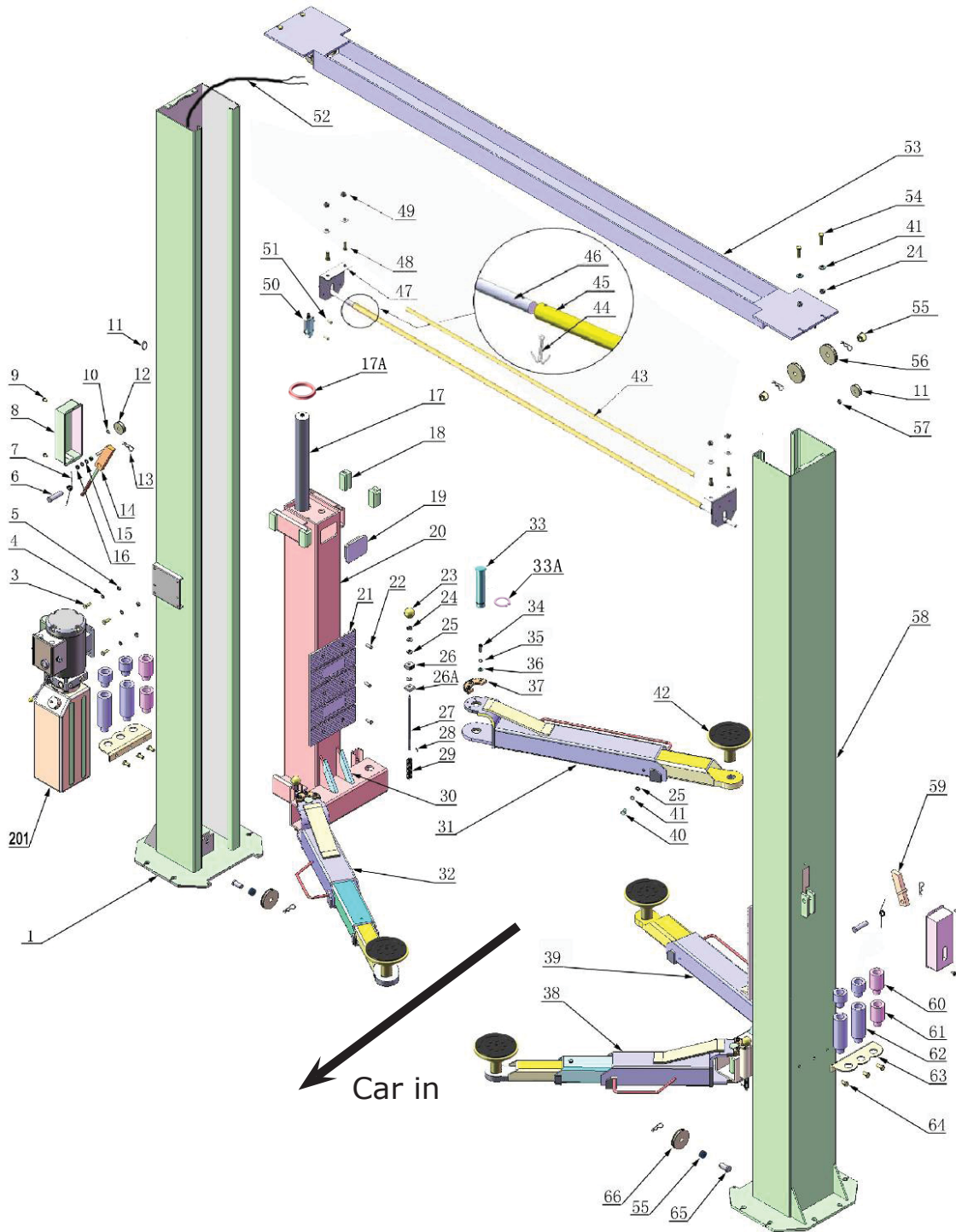


Fig. 33

# Cylinders

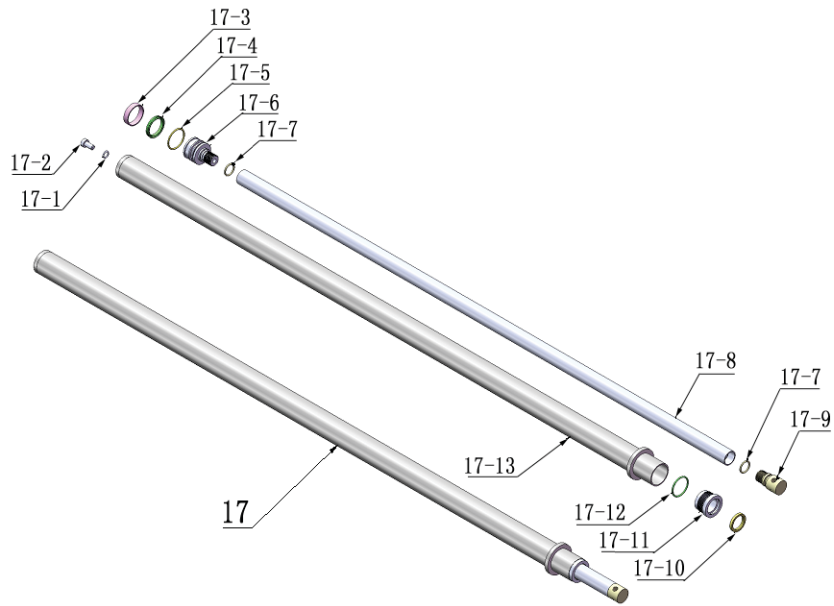


Fig. 34

# SPX Manual Power Unit, 220V/50Hz, Single phase

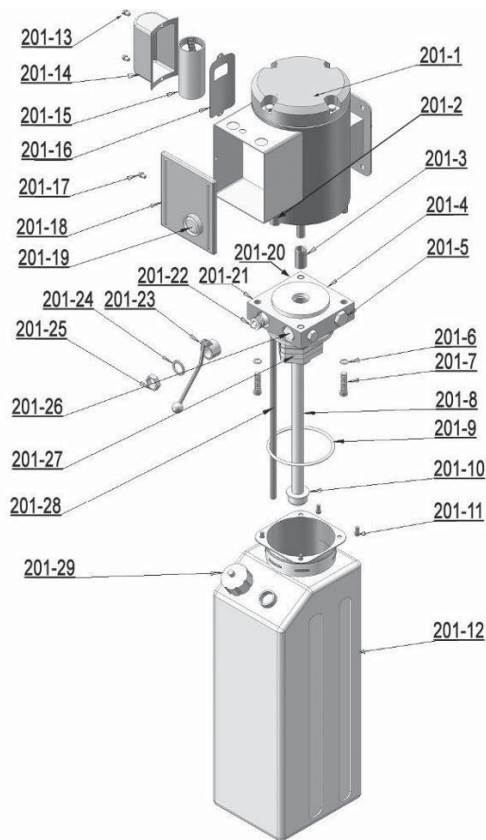


Fig. 35

# Atlas Manual Power Unit

220V/50HZ/1 phase

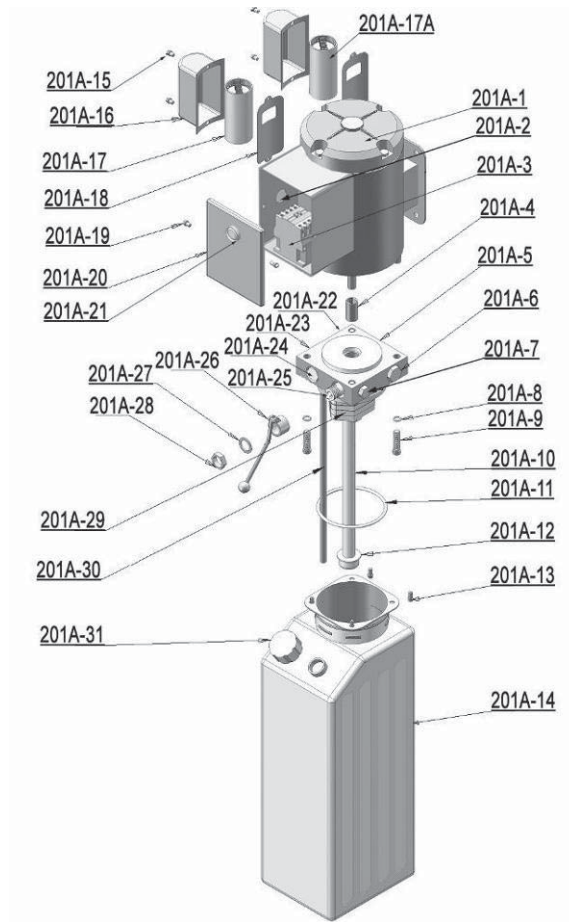


Fig. 36

# Illustration of hydraulic valve for SPX & Atlas power unit

a. SPX manual power unit, 220V/50HZ, Single phase (See Fig. 37)

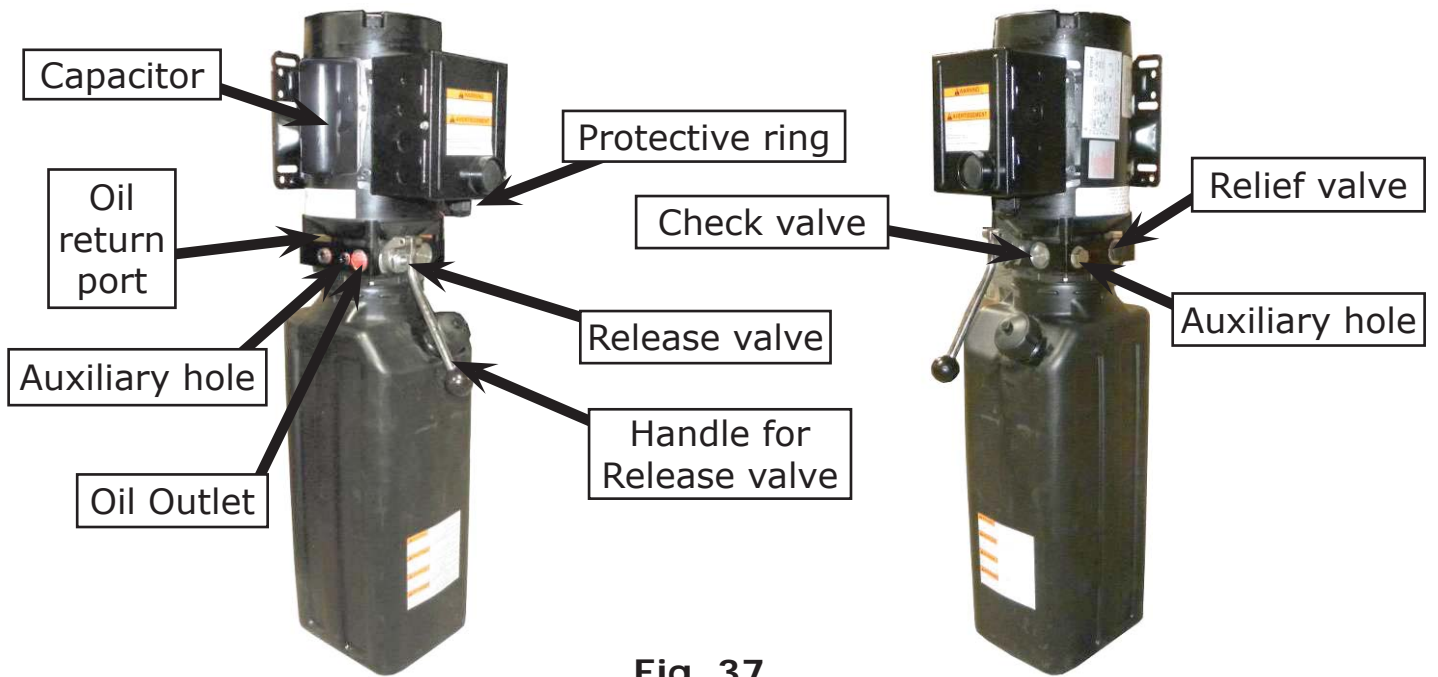


Fig. 37

b. Atlas manual power unit, 220V/50HZ, Single phase (See Fig. 38)

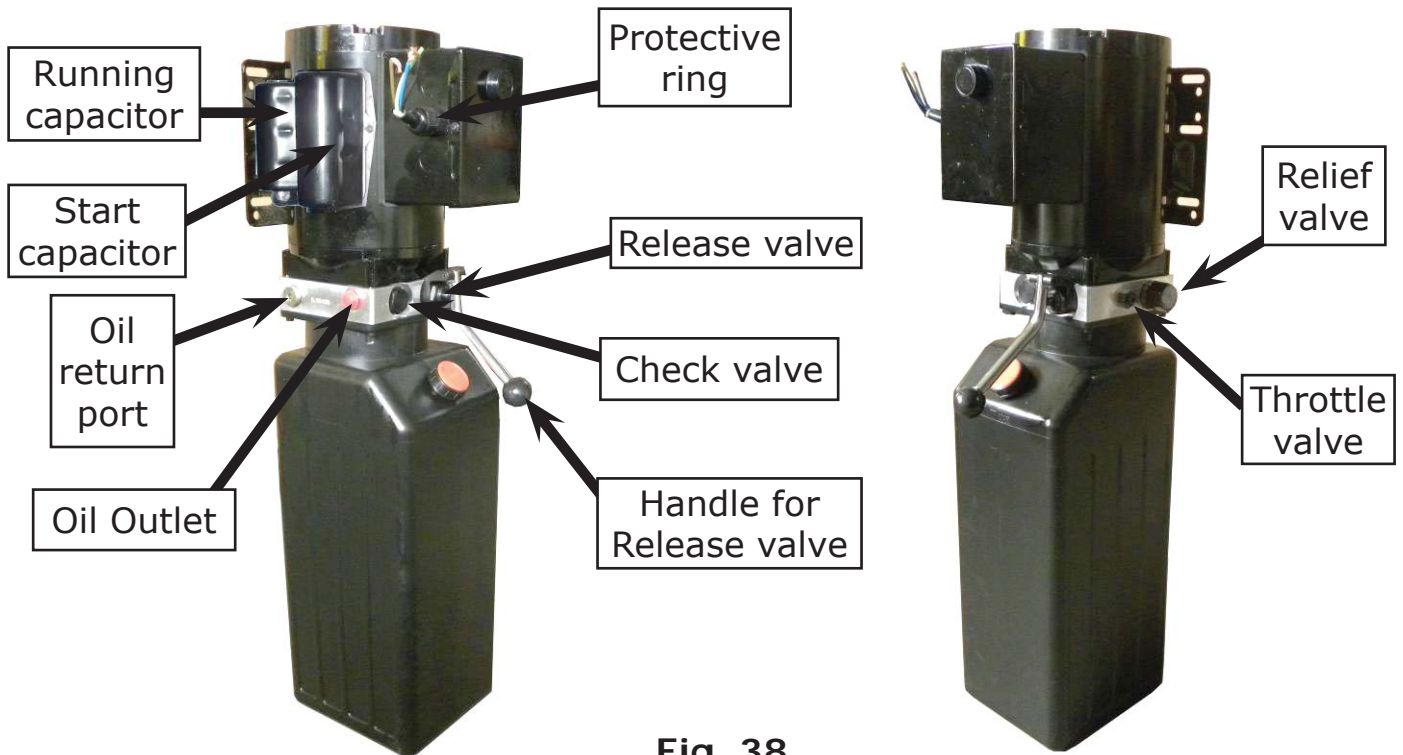


Fig. 38

# Test Run

---

## 1. Adjust synchronous cable (See Fig. 39)

Use wrench to hold the cable fitting, meanwhile use ratchet spanner to tighten the cable nut. Make sure two cables are with the same tension so that two carriages can work synchronously. Fit the plastic hole cover on the lifting carriages.

**If the carriages do not Synchronize when lifting, please tighten the cable nut of lower side carriage.**



Fig. 39

## 2. Adjust safety cable

Lifting the carriages and locking at the same height, strain the safety cable and then release a little, and then tighten the cable nuts. Make sure the safety device can always be worked properly.

## 3. Bleeding air

This hydraulic system is designed to bleed air by loosening the bleeding plug. Lifting the carriages to about 1 meter height, and loose the bleeding plug, the air would be bled automatically, then tighten the plug after bleeding, the lift would work stably and smoothly, otherwise repeat bleeding (See Fig. 40).

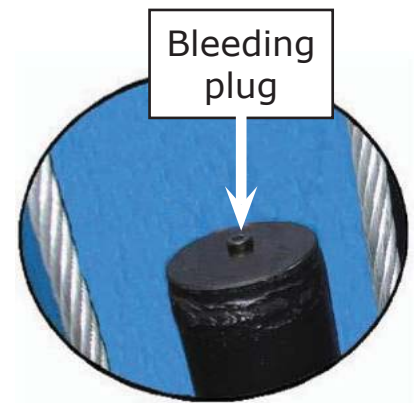
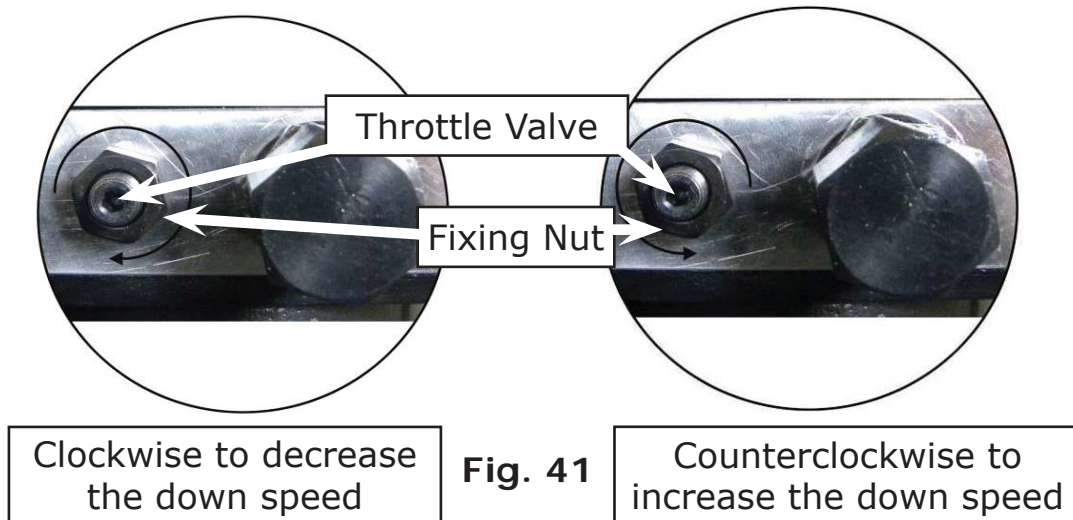


Fig. 40



#### 4. Adjust the lower speed (Only for Atlas power unit)

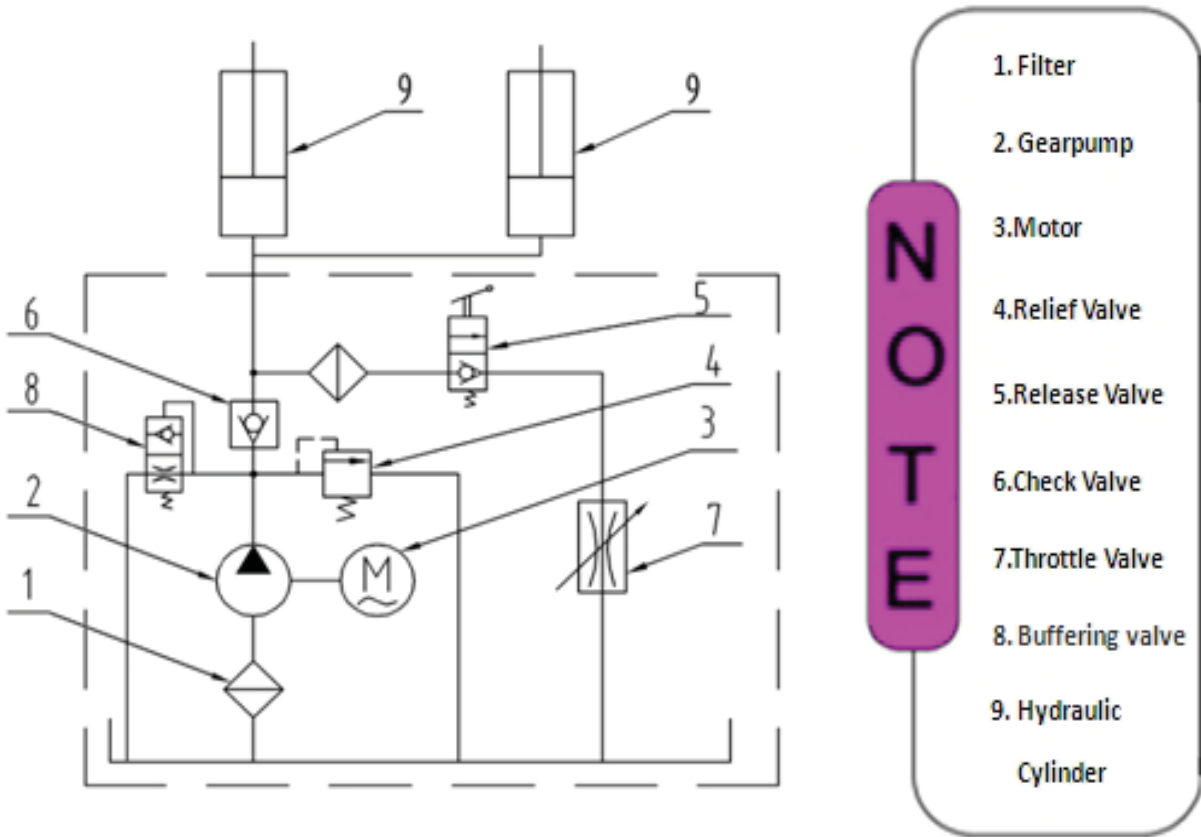
You can adjust the lower speed of the lift if needing: Loosen the fixing nut of the throttle valve, and then turn the throttle valve clockwise to decrease the lower speed, or counterclockwise to increase the lower speed. Do not forget to tighten the fixing nut after the lower speed adjustment has been done.



#### 5. Test with load

After finishing the above adjustment, test running the lift with load. Run the lift in low position several times first, making sure the lift can rise and lower synchronously, and the safety device can lock and release synchronously. And then test run the lift to the top completely. If there is anything improper, repeat the above adjustment.

**NOTE:** If the lift vibrates on the way up with a load, lubricate all pulley shafts and wear blocks. If the lift vibrates on the way down, the cylinders need to be bled again.



**Fig. 42 - Hydraulic System**



# Operation Instructions

---

**Please read the safety tips carefully before operating the lift.**

## **To lift vehicle**

1. Keep work area clean around and under the lift;
2. Position lift arms to the lowest position;
3. To shortest lift arms;
4. Open lift arms;
5. Position vehicle between columns;
6. Move arms to the vehicle's lifting point;

**Note: The four lift arms must at the same time contact the vehicle's lifting point where manufacturers recommended**

7. Press the **UP** button until the lift pads contact underside of vehicle totally. Recheck to make sure vehicle is secure;
8. Continue to raise the lift slowly to the desired working height, ensuring the balance of vehicle;
9. Push lowering handle to lower lift onto the nearest safety. The vehicle is ready to repair.

## **To lower vehicle**

1. Keep the lift area free of clutter;
2. Press the button of **UP** to raise the vehicle slightly, and then release the safety device, lower vehicle by pushing lowering handle.
3. Open the arms and position them to the shortest length;
4. Drive away the vehicle.
5. Turn off the power.

# Maintenance Schedule

---

## Monthly:

1. Re-torque the anchor bolts to 65-86 ft lbs;
2. Check all connectors, bolts and pins to insure proper mounting;
3. Lubricate cable with lubricant;
4. Make a visual inspection of all hydraulic hoses/lines for possible wear or leakage;
5. Check safety device and make sure proper condition;
6. Lubricate all rollers and pins with 90wt. Gear oil or equivalent;

**Note: All anchor bolts should take full torque. If any of the bolts does not function for any reason, DO NOT use the lift until the bolt has been replaced.**

## Every six months:

1. Make a visual inspection of all moving parts for possible wear, interference or damage.
2. Check and adjust as necessary, equalizer tension of the cables to insure level lifting.
3. Check columns for plumbness.
4. Check rubber pads and replace as necessary.
5. Check safety device and make sure proper condition.

# Trouble Shooting

---

TROUBLE	CAUSE	REMEDY
Motor does not run	<ol style="list-style-type: none"> <li>1. Button does not work</li> <li>2. Wiring connections are not in good condition</li> <li>3. Motor burned out</li> <li>4. Height Limit Switch is damaged</li> <li>5. AC Contactor burned out</li> </ol>	<ol style="list-style-type: none"> <li>1. Replace button</li> <li>2. Repair all wiring connections</li> <li>3. Repair or replace motor</li> <li>4. Replace the Limit Switch</li> <li>5. Replace AC Contactor</li> </ol>
Motor runs but the lift is not raised	<ol style="list-style-type: none"> <li>1. Motor runs in reverse rotation</li> <li>2. Gear Pump out of operation</li> <li>3. Release Valve in damage</li> <li>4. Relief Valve or Check Valve is damaged</li> <li>5. Low oil level</li> </ol>	<ol style="list-style-type: none"> <li>1. Reverse two power wire</li> <li>2. Repair or replace</li> <li>3. Repair or replace</li> <li>4. Repair or replace</li> <li>5. Fill tank</li> </ol>
Lift does not stay up	<ol style="list-style-type: none"> <li>1. Release Valve out of work</li> <li>2. Relief Valve or Check Valve leakage</li> <li>3. Cylinder or Fittings leaks</li> </ol>	Repair or replace
Lift raises slowly	<ol style="list-style-type: none"> <li>1. Oil line is jammed</li> <li>2. Motor running on low voltage</li> <li>3. Oil mixed with Air</li> <li>4. Gear Pump leaks</li> <li>5. Overload lifting</li> </ol>	<ol style="list-style-type: none"> <li>1. Clean the oil line</li> <li>2. Check electrical system</li> <li>3. Fill tank</li> <li>4. Replace Pump</li> <li>5. Check load</li> </ol>
Lift cannot lower	<ol style="list-style-type: none"> <li>1. Safety device are locking</li> <li>2. Release Valve in damage</li> <li>3. Safety cable broken</li> <li>4. Oil system is jammed</li> </ol>	<ol style="list-style-type: none"> <li>1. Release the safeties</li> <li>2. Repair or replace</li> <li>3. Replace</li> <li>4. Clean the oil system</li> </ol>

# 10-OHSC Parts List

---

Item	Part#	Description	Qty.	Note
<b>(See Fig.33, Fig.8, Fig. 13, Fig. 15)</b>				
1	211001	Powerside Column	1	
201	209002	Manual Power Unit	1	
3	209003	Hex Bolt	4	
4	209004	Rubber Ring	4	
5	209005	Nylock Nut	4	
6	206002	Safety Pin	2	
7	209007	Safety Spring	2	
8	209008	Safety Cover	2	
9	209009	Cup Head Bolt	4	
10	209010	Snap Ring	1	
11	620059	Protective ring	1	
12	209049	Plastic small pulley	3	
13	209012	Hair Pin	8	
14	209013	Powerside Safety Lock	1	
15	206006	Washer	6	
16	206023A	Hex Nut	2	
17	209014	Cylinder	2	
17A	209111	Protective ring for cylinder	2	
18	209015	Slider Block	16	
19	209016	Carriage Plastic Cover	2	
20	211002	Carriage	2	
21	209018	Protective Rubber	2	
22	209019	Bolt	12	
23	209020	Plastic Ball	4	
24	209021	Hex Nut	12	

<b>Item</b>	<b>Part#</b>	<b>Description</b>	<b>Qty.</b>	<b>Note</b>
25	209022	Washer	10	
26	209023A	Arm Lock	4	
26A	201041	Limit ring	4	
27	209024	Arm Lock Bar	4	
28	209025	Hair Pin	4	
29	209026	Spring	4	
30	209027	Protective Rubber Set	4	
31	209028A	Lifting Arm - Rear Right	1	
31A	209179	Outer Arm - Rear Right	1	
31B	209136B	Inner Arm - Rear Right	1	
32	209029A	Lifting Arm - Front Right	1	
32A	209137	Outer Arm - Front Right	1	
32B	206088	Middle Arm - Front Right	1	
32C	206089A	Inner Arm - Front Right	1	
33	203105A	Arm Pin	4	
33A	520023	Snap Ring	4	
34	209032	Socket Bolt	12	
35	209034	Lock Washer	18	
36	209033	Washer	12	
37	209035	Moon Gear	4	
38	209036A	Lifting Arm - Front Left	1	
38A	209177	Outer Arm - Front Left	1	
38B	206093	Middle Arm - Front Left	1	
38C	206089A	Inner Arm - Front Left	1	
39	209037A	Lifting Arm - Rear Left	1	
39A	209186	Outer Arm - Rear Left	1	
39B	209140A	Inner Arm - Rear Left	1	
40	209038	Hex Bolt	6	
41	209039	Lock Washer	10	
42	217114A	Rubber Pad Assembly	4	

Item	Part#	Description	Qty.	Note
42A	420138	Socket bolt	4	
42B	209134	Rubber Pad	4	
42C	680030B	Rubber Pad Frame	4	
43	206025A	Foam Cushion	1	
44	201005	Split pin	2	
45	206025C	Connecting Pin for Control Bar	2	
46	202011	Control Bar	1	
47	206042	Control Bar Bracket	2	
48	206041	Hex Bolt	4	
49	206023	Nylock Nut	4	
50	206013	Limit Switch	1	
51	206011	Cup Head Bolt	2	
52	209184	Wire Cable	1	
53	211011	Top Beam	1	
	211011A		0	
54	209046	Hex Bolt	4	
55	209057A	Bronze Bush	6	
56	209057	Small Pulley	4	
57	209056	Nylock Nut	2	
58	211012	Offside Column	1	
59	211013	Offside Safety Lock	1	
60	209051B	Stackable Adapter(1.5")	4	
61	209052B	Stackable Adapter (2.5")	4	
62	209053B	Stackable Adapter (5")	4	
63	209054A	Stackable Adapter Bracket	2	
64	209055	Hex Bolt	6	
65	209044	Pin For Pulley	2	
66	209045	Big Pulley	2	
67	209059B	Anchor Bolt	12	
67A	620065	Shim	10	

Item	Part#	Description	Qty.	Note
<b>Parts List for Oil Hose, Fitting &amp; Cable (See Fig. 18-22)</b>				
68	209060	90° Fitting for power unit	1	
69	211014	Oil hose	1	
70	211016	T- fitting	1	
71	211015A	Oil hose	2	
71A	211020	Oil hose	0	
72	211017	Extend 90° fitting for Cylinder	2	
73	209066	Cable Nut	4	
74	211018	Cable	2	
	211018A		0	
75	211019	Safety Cable	1	
	211019A		0	
76	209501B	Parts Box	1	
77	209502B		0	
<b>Parts for Cylinder (See Fig. 34)</b>				
17-1	209069	O-Ring	2	
17-2	209070	Bleeding Plug	2	
17-3	209071	Support Ring	2	
17-4	209072	Y-Ring	2	
17-5	209073	O-Ring	2	
17-6	209074	Piston Rod	2	
17-7	209075	O-Ring	4	
17-8	209076	Piston Rod	2	
17-9	209077	Piston Rod Fitting	2	
17-10	209078	Dust Ring	2	
17-11	209079	Head Cup	2	
17-12	209080	O-Ying	2	
17-13	209081	Bore Weldment	2	

Item	Part#	Description	Qty.	Note
<b>Parts for SPX manual power unit, 220V/50Hz/1 phase (See Fig. 35)</b>				
201-1	209082	Motor	1	
201-2	209109	Protective ring	1	
201-3	209083	Motor connecting shaft	1	
201-4	209084	Valve body	1	
201-5	209085	Relief valve	1	
201-6	209086	Lock washer	4	
201-7	209087	Allen bolt	4	
201-8	209088	Inlet pipe	1	
201-9	209089	O-Ring	1	
201-10	209090	Filter	1	
201-11	209091	Bolt	4	
201-12	209092	Reservoir	1	
201-13	209093	Bolt	2	
201-14	209094	Cover of capacitor	1	
201-15	209095	Capacitor	1	
201-16	209096	Rubber gasket	1	
201-17	209097	Bolt	1	
201-18	209098	Cover of motor terminal box	1	
201-19	209099	Push button	1	
201-20	209110	Oil return port	1	
201-21	209100	Oil outlet	1	
201-22	209101	Release valve	1	
201-23	209102	Handle for release valve	1	
201-24	209103	Washer	1	
201-25	209104	Nut	1	
201-26	209105	Check valve	1	
201-27	209106	Gear pump	1	
201-28	209107	Oil return pipe	1	
201-29	209108	Filler cap	1	



Item	Part#	Description	Qty.	Note
<b>Parts for Atlas manual power unit, 220V/50Hz/1 phase (See Fig. 36)</b>				
201A-1	209082A	Motor	1	
201A-2	209109	Protective ring	1	
201A-3	209112	AC contactor	1	
201A-4	209083A	Motor connecting shaft	1	
201A-5	209084A	Valve body	1	
201A-6	209085A	Relief valve	1	
201A-7	209113	Throttle valve	1	
201A-8	209086A	Lock washer	4	
201A-9	209087A	Allen bolt	4	
201A-10	209088A	Inlet pipe	1	
201A-11	209089A	O-Ring	1	
201A-12	209090A	Filter	1	
201A-13	209091A	Allen bolt	4	
201A-14	209092A	Reservoir	1	
201A-15	209093A	Cup head bolt with washer	4	
201A-16	209094A	Cover of capacitor	2	
201A-17	209095A	Start capacitor	1	
201A-17A	209095B	Run capacitor	1	
201A-18	209096A	Rubber gasket	2	
201A-19	209097A	Cup head bolt with washer	2	
201A-20	209098A	Cover of motor terminal box	1	
201A-21	209099A	Push button	1	
201A-22	209110A	Oil return port	1	
201A-23	209100A	Oil outlet	1	
201A-24	209105A	Check valve	1	
201A-25	209101A	Release valve	1	
201A-26	209102A	Handle for release valve	1	
201A-27	209103A	Washer	1	
201A-28	209104A	Nut	1	
201A-29	209106A	Gear pump	1	
201A-30	209107A	Oil return pipe	1	
201A-31	209108A	Filler cap	1	

# Warranty

---



**This item** is warranted for five (5) years on structural components, two (2) years on hydraulic cylinders, and one (1) year on electric or air / hydraulic power units from invoice date. Wear items are covered by a 90 day warranty.

This LIMITED warranty policy does **not include a labor** warranty.

**NOTE: ALL WARRANTY CLAIMS MUST BE PRE-APPROVED BY THE MANUFACTURER TO BE VALID.**

The Manufacturer shall repair or replace at their option for this period those parts returned to the factory freight prepaid, which prove after inspection to be defective. This warranty will not apply unless the product is installed, used and maintained in accordance with the Manufacturers installation, operation and maintenance instructions.

This warranty applies to the ORIGINAL purchaser only, and is non-transferable. The warranty covers the products to be free of defects in material and workmanship but, does not cover normal maintenance or adjustments, damage or malfunction caused by: improper handling, installation, abuse, misuse, negligence, carelessness of operation or normal wear and tear. In addition, this warranty does not cover equipment when repairs or alterations have been made or attempted to the Manufacturer's products.

THIS WARRANTY IS EXCLUSIVE AND IS LIEU OF ALL OTHER WARRANTIES EXPRESSED OR IMPLIED INCLUDING ANY IMPLIED WARRANTY OR MERCHANTABILITY OR ANY IMPLIED WARRANTY OF FITNESS FROM A PARTICULAR PURPOSE, AND ALL SUCH IMPLIED WARRANTIES ARE EXPRESSLY EXCLUDED.

THE REMEDIES DESCRIBED ARE EXCLUSIVE AND IN NO EVENT SHALL THE MANUFACTURER, NOR ANY SALES AGENT OR OTHER COMPANY AFFILIATED WITH IT OR THEM, BE LIABLE FOR SPECIAL CONSEQUENTIAL OR INCIDENTAL DAMAGES FOR THE BREACH OF OR DELAY IN PERFORMANCE OF THIS WARRANTY. THIS INCLUDES, BUT IS NOT LIMITED TO, LOSS OF PROFIT, RENTAL OR SUBSTITUTE EQUIPMENT OR OTHER COMMERCIAL LOSS.

**PRICES:** Prices and specifications are subject to change without notice. All orders will be invoiced at prices prevailing at time of shipment. Prices do not include any local, state or federal taxes.

**RETURNS:** Products may not be returned without prior written approval from the Manufacturer.

DUE TO THE COMPETITIVENESS OF THE SELLING PRICE OF THESE LIFTS, THIS WARRANTY POLICY WILL BE STRICTLY ADMINISTERED AND ADHERED TO.