



# Atlas Edge 401 & 601 Wheel Alignment Machines

## INSTALLATION & OPERATION MANUAL



### INDIANA

5800 MASSACHUSETTS AVE.  
INDIANAPOLIS, IN 46218

PHONE: (800) 262-1950  
FAX: (317) 542-1448

### DELAWARE

250 EXECUTIVE DRIVE, SUITE 1  
NEWARK, DE 19702

PHONE: (800) 715-1950  
FAX: (302) 894-9136

### GEORGIA

2375 BUTTON GWINNETT DR., SUITE 100  
ATLANTA, GA 30340

PHONE: (800) 768-4104  
FAX: (678) 781-0149

### ARIZONA

8399 W VAN BUREN ST., SUITE 210  
TOLLESON, AZ 85353

PHONE: (800) 602-9928  
FAX: (602) 490-3495

### NEW HAMPSHIRE

8 INDUSTRIAL DRIVE  
HUDSON, NH 03051

PHONE: (800) 360-0053

### FLORIDA

11801 NW 100th RD., SUITE 8  
MEDLEY, FL 33178



PHONE: (800) 305-5609

### TEXAS

3206 INDUSTRIAL TERRACE, SUITE 102  
AUSTIN, TX 78758

PHONE: (800) 512-7611

## SYMBOLS USED IN THE MANUAL

	SYMBOLS
	<b>FORBIDDEN!</b>
	<b>Mandatory!</b> Operations or jobs to be performed compulsorily
	<b>Hazard!</b> Be especially careful

# CONTENTS

<b>0</b>	<b>CAUTION</b> .....	<b>3</b>
0.1	Preliminary Safety Information .....	3
<b>1</b>	<b>INTENDED USE</b> .....	<b>4</b>
<b>2</b>	<b>OPERATOR TRAINING</b> .....	<b>4</b>
2.1	General Preventive Measures .....	4
<b>3</b>	<b>MACHINE OVERVIEW</b> .....	<b>5</b>
3.1	Models (Edge 401-601) Overview .....	5
3.2	Safety Devices .....	6
3.3	Measurement Range and Accuracy .....	6
3.4	Overall Dimensions .....	6
3.5	Managing PC .....	6
3.6	Sensors .....	7
3.6.1	Front Sensors .....	8
3.6.2	Rear Sensors .....	8
3.6.3	Sensor Keypads .....	9
3.6.4	LED indicating Levelling and Tolerance during Adjustment .....	9
3.7	Clamps .....	10
3.7.1	4 Point Clamps .....	10
3.7.2	3 Point Fast Clamps .....	10
<b>4</b>	<b>SWITCHING THE MACHINE ON AND OFF</b> .....	<b>11</b>
4.1	Switching the Machine On .....	11
4.2	Switching the Machine Off .....	11
<b>5</b>	<b>SENSORS AUTOMATIC POWER OFF</b> .....	<b>13</b>
<b>6</b>	<b>LOW BATTERY INDICATOR</b> .....	<b>13</b>
<b>7</b>	<b>PROGRAM CONFIGURATION</b> .....	<b>14</b>
7.1	DATABASE Groups Configuration .....	15
<b>8</b>	<b>VEHICLE DIAGNOSIS AND ADJUSTMENT</b> .....	<b>17</b>
8.1	Introduction Page .....	17
8.2	Vehicle Make and Model Selection .....	17
8.3	Selected Vehicle Technical Specification Displaying .....	20
8.4	Preliminary Operations .....	21
8.4.1	Vehicle Check Preliminary Operations .....	21
8.4.2	Run-Out Preparation .....	21
8.5	Run-Out .....	22
8.5.1	Run-Out with Raised Wheels .....	22
8.5.2	Thrust Run-Out with Automatic Acquisition .....	25
8.6	Measurement Preliminary Operations .....	30
8.7	Sensors Alignment and Levelling .....	31
8.8	Steering Procedure .....	32
8.9	Vehicle Diagnosis .....	33
8.10	Adjustment Preliminary Operations .....	34
8.11	Rear Axle Adjustment .....	34
8.12	Front Axle Adjustment .....	35
8.13	Additional Functions Menu .....	36
8.14	Printout of Measurements taken .....	37
<b>9</b>	<b>DATABASE CUSTOMIZATION</b> .....	<b>40</b>
9.1	New Group Entry .....	40
9.2	New Group Deletion .....	41

9.3	New Vehicle Entry .....	42
9.4	Customized Vehicle Deletion .....	45
<b>10</b>	<b>PROGRAM AND DATABASE PROTECTION SMART CARD .....</b>	<b>46</b>
10.1	DATABASE Management .....	46
<b>11</b>	<b>SENSORS' ERRORS .....</b>	<b>48</b>
11.1	Data Reception/Transmission Error between Sensors and Cabin.....	48
11.2	Angle Measurement Horizontal Error .....	48
<b>12</b>	<b>TROUBLESHOOTING .....</b>	<b>49</b>
<b>13</b>	<b>MAINTENANCE.....</b>	<b>49</b>
<b>14</b>	<b>STORAGE AND SCRAPPING.....</b>	<b>50</b>
<b>15</b>	<b>MACHINE IDENTIFICATION DATA .....</b>	<b>50</b>



Bluetooth brands are property of their owners, and are used by Atlas Equipment under license.

## 0 CAUTION

Any damage caused by failure to follow the instructions in this manual or improper machine use shall relieve Atlas Equipment of all liability.

### 0.1 Preliminary Safety Information



#### **Before starting the machine:**

- Read the instructions and the entire manual before using or working on the wheel aligner. This manual represents an integral part of the product and is intended to inform the user on how to use the Atlas Edge 401 and 601 wheel aligner. Keep the manual for the entire life of the machine. Keep it in an easy to access place and refer to it every time the need arises. All machine operators must be able to read the manual.
- Make sure the power supply is in conformity with the specifications shown on the plate. Voltage and frequency data plate is positioned on machine back side. Please, read plate data. NEVER connect aligner to a voltage or frequency other than the specified ones.
- Duly arrange wheel aligner power cable. This product features a 3-wire plug with built-in grounding. It can be plugged into a socket with built-in grounding, only. Should a grounded socket not be available for machine connection, contact an electrician. Do not tamper with or misuse plug.

#### **Upon machine switching off:**

- Do not switch off the built-in PC by unplugging it or by turning PC switch to off, but follow the procedure set forth in par.4.2 on page 11. Improperly switching off the PC could lead to HARD-DISK file "corruption".
- The switching off procedure set forth in par. 4.2 on page 11 does not affect sensor recharge supports, which continue being powered.

#### **In emergency conditions and before performing any maintenance:**

- Insulate the machine against any power source using the special master switch, and remove plug from power socket.
- Do not try to service this unit arbitrarily, as the opening or removal of machine doors could expose user to hazardous voltage. Maintenance operations shall be carried out by authorised service personnel, only.

#### **Work environment and machine cleaning:**

- The work environment must be kept clean and dry, and must not be exposed to atmospheric agents. It must also be well lit.
- Do not clean the machine using jets of water and compressed air. To clean plastic panels or surfaces use a moist cloth (avoid using liquids containing solvents).

*Atlas Equipment shall be entitled to make any changes to the models described in this manual at any time for reasons of a technical and commercial nature.*

# 1 INTENDED USE

Atlas Edge 401 and 601 systems are machines for the detection of all vehicle special angles. Angles are detected by four sensors with microprocessor technology and infrared measurement system, and data transmission (without any cable connection between sensors).

The data of front cabin sensors are transmitted VIA RADIO through  **Bluetooth**<sup>®</sup>

Vehicle max. allowed wheelbase length for data transmission and angle measurement is 14.5 ft.

Machine operational temperature range: 32 to 140°F.

# 2 OPERATOR TRAINING

The machine must be used by specifically trained and authorised personnel, only. To ensure proper machine use and that measurements can be efficiently taken, operators must be correctly trained and acquire the skills consistent with the instructions provided by the manufacturer. In case of any doubts relating to machine use and maintenance, refer to the instruction manual and then, if such doubts persist, contact an authorised after-sales center or Atlas Equipment technical assistance directly.

## 2.1 General Preventive Measures



- During operation and maintenance of this machine, always abide by the safety and accident-prevention regulations in force.



- The machine must only be used by adequately trained and authorised persons.



- This machine must only be used for the purpose for which it was expressly intended. Atlas Equipment declines all liability for injury or damage to persons animals and things caused by improper machine use.



- Accessories and spare parts must be fitted by persons authorised by Atlas Equipment and only original spare parts and accessories must be used.



- The machine must only be operated in places where there is no danger of explosions or fire.



- Removal or changes made to safety devices, or warning signals on the machine can cause serious hazards and represent a violation of safety regulations.



- Before doing any maintenance jobs on the system, always disconnect the power supply.

In case of doubt, do not interpret, but contact Atlas Equipment technical assistance in order to obtain instructions suitable for performing operations in total safety.



- Do not allow unauthorised personnel to come near the wheel aligner during use.



### 3 MACHINE OVERVIEW

#### 3.1 Edge 401– 601 Overview

##### PC KEYBOARD

Machine features a 102-key, PC-type command keyboard. Function keys allow using almost all machine functions. Vehicle general data, customer data, and vehicle database customization can also be entered via PC keyboard.

##### MONITOR

All models feature a high-definition, color monitor. Monitor use and maintenance instructions can be found on the manual coming with the monitor itself. Comply with these instructions.

##### MANAGING PC UPPER COMPARTMENT

For PC characteristics see par. 3.5 page 6

##### PRINTER CENTRAL COMPARTMENT

Results are printed with a inkjet color printer. Printer use and maintenance instructions can be found on the manual coming with the printer itself. Comply with these instructions.



**SHOCK HAZARD**  
**POWER SOCKET**

**MACHINE MASTER SWITCH**

**SENSORS POSITIONED ONTO RECHARGE PORTS**  
See par. 3.6 page 7

##### CLAMPS

See par. 3.7 page 10



**STEERING LOCK** is a tool used to keep vehicle steering in a fixed position. It is used before the adjustment procedure, as shown by the instructions displayed during program.



**PEDAL DEPRESSOR** is a tool used to lock brake pedal during measurement preliminary operations. It has to be used as shown in the instructions displayed during program.



### 3.2 Safety Devices

Wheel aligner features a safety device (master switch) positioned on the rear of the machine. Master switch cuts off machine power when set to “0”.

### 3.3 Measurement Range and Accuracy

Axle	Measurement	Accuracy	Measurement Range	Measurement Total Range
Front	Toe	± 2'	± 2°	± 20° x 2
	Partial toe	± 1'	± 1°	± 20°
	Set-back	± 2	± 2°	± 5°
	Camber	± 2'	± 3°	± 10°
	Caster	± 5'	± 10°	± 18°
	Kingpin	± 5'	± 10°	± 18°
Rear	Toe	± 2'	± 2°	± 20° x 2
	Partial toe	± 1'	± 1°	± 20°
	Set-back	± 2'	± 2°	± 5°
	Camber	± 2'	± 3°	± 10°
	Thrust angle	± 2'	± 2°	± 5°

### 3.4 Overall Dimensions

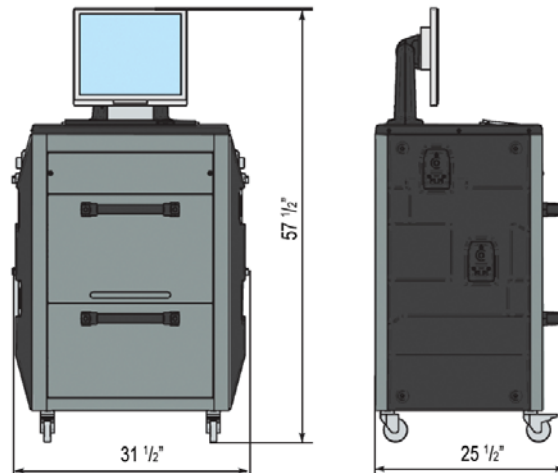

Figure 1

### 3.5 Managing PC

Software is installed on managing PC (personal computer), positioned inside cabin. EPIA 8001 managing PC features:

- Processor VIA Nano 64bit @ 1.6GHz.
- RAM 1 Gb;
- Smart card reader
- 4 USB; 1 LAN Ethernet 10/100Mb;
- PS2 keyboard and mouse input; Windows XP Embedded Standard 2009™ operating system, in English language
- 1366x768 Pixels HD Ready video output
- Hard Disk ≥ 160 Gb



### 3.6 Sensors

Edge 601 sensors do not need any cable or cord connection for angle measurement.

Edge 401 front two sensors are connected to the cabin with cables.

Sensor units consist of infrared data transmitters/receivers and CCD-type transducers with infrared emitter focal point.

All the characteristic angles of vehicle axles are controlled with 6 CCD sensors and infrared transmission.

Data transmission among infrared sensors is effective also under critical lighting conditions.

Data is transmitted from front sensors VIA RADIO through modules  **Bluetooth**® located inside front sensors and cabin.

Rear sensors do not communicate directly with cabin: their data are transmitted/received through front sensors, via infrared ray transmission.

Power is supplied by rechargeable 6V long-lasting batteries. Front and rear sensors are recharged thanks to the battery recharge ports positioned onto the cabin.

For all sensors with rechargeable batteries, power supply and consumption data are the following:

	<b>REAR SENSORS</b>	<b>FRONT SENSORS</b>
Power supply	Lead battery 6V - 3.3Ah	Lead battery 6V - 3.3Ah h
Average operation with fully effective and charged battery	Approx. 12 hours	Approx. 10 hours
Average recharge time	Approx. 10 hours	Approx. 10 hours

### 3.6.1 Front Sensors

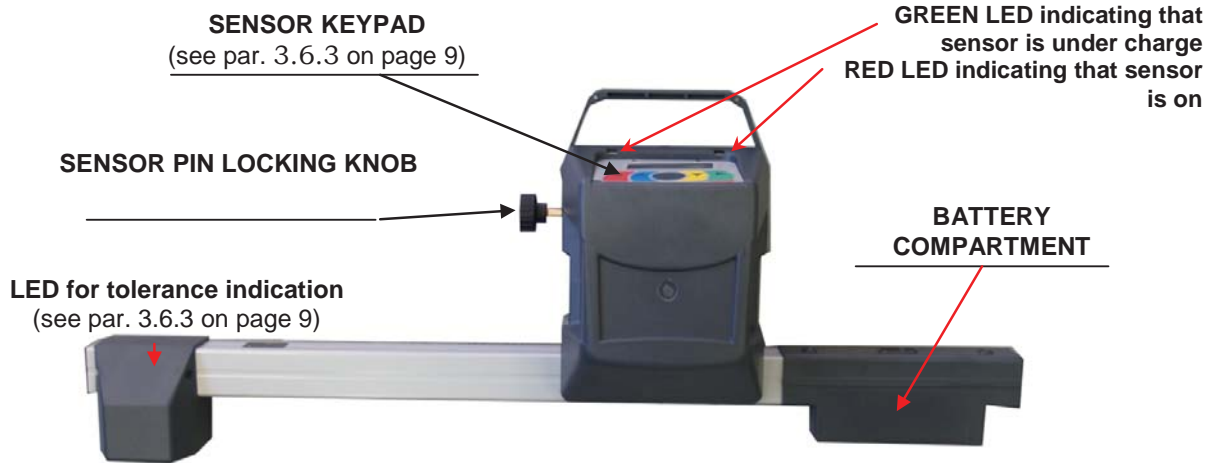

Figure 2

### 3.6.2 Rear Sensors

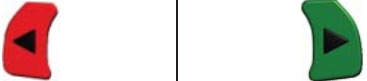

Figure 3

### 3.6.3 Sensor Keypads



Figure 4

KEYS	DESCRIPTION
	Sensor switch-on key.
	If pressed at the same time, they allow sensor manual switching off.

Legend of Figure 4:

- |     |                      |   |
|-----|----------------------|---|
| A - | • Green LED on:      | sensor battery is under charge  |
| B - | • Red LED steady on: | sensor is on  |
|     | • Red LED flashing:  | sensor is battery is low (when battery residual charge is lower than or equal to 30%); it will turn off after a few minutes |

### 3.6.4 LED indicating Levelling and Tolerance during Adjustment

Sensors (see par. 3.6.1 and 3.6.2) are equipped with LED indicators for their correct levelling and for tolerance during adjustment.

#### Leveling indicator

- RED LED on → sensor is not levelled
- RED LED flashing and GREEN LED steady on → sensor is close, but not levelled
- GREEN LED ONLY is flashing → sensor is levelled
- RED LED flashing and GREEN LED steady on → sensor is close, but not levelled
- RED LED on → sensor is not levelled

#### Tolerance indicator during adjustment

- GREEN LED flashing → measurement is within tolerance, exactly at the centre
- RED LED flashing and GREEN LED steady on → measurement is within tolerance
- RED LED on → measurement is NOT within tolerance

Note: during front adjustment, if you want to observe tolerance onto LEDs, take the red selection frame on the value you are adjusting (see 8.12 on page 35).

During rear adjustment, on the contrary, tolerance is indicated both on horizontal LEDs (toe) and vertical LEDs (camber).

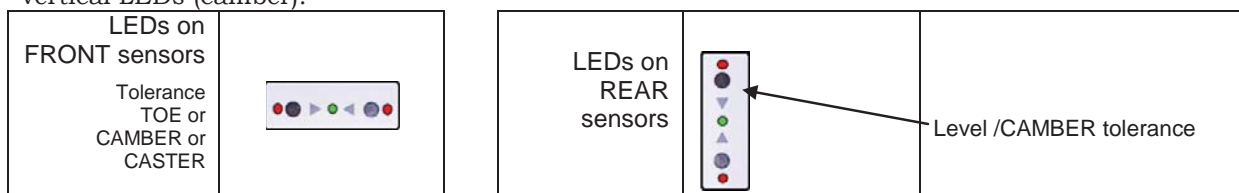

### 3.7 Clamps

Two types of clamps are available, depending on different needs.

#### 3.7.1 4 Point Clamps

Screw-on self-centering type for 10" to 19" alloy rims, with removable tabs.

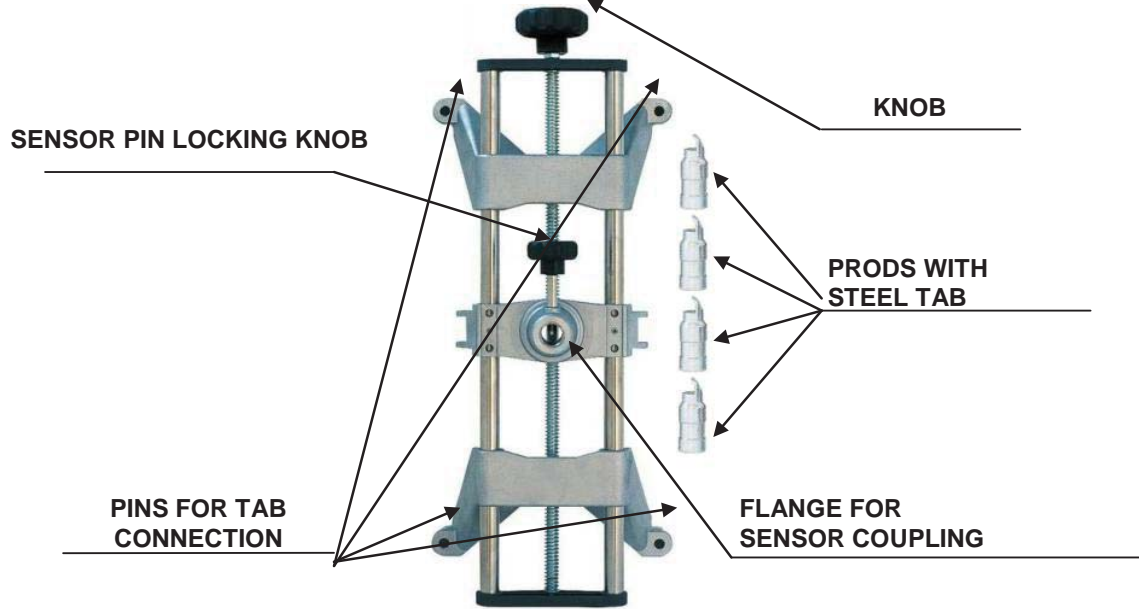

Figure 5

#### 3.7.2 3 Point Fast Clamps

3-resting point self-centering type for 10" to 20" rims, with manual approach and locking unit on tire.

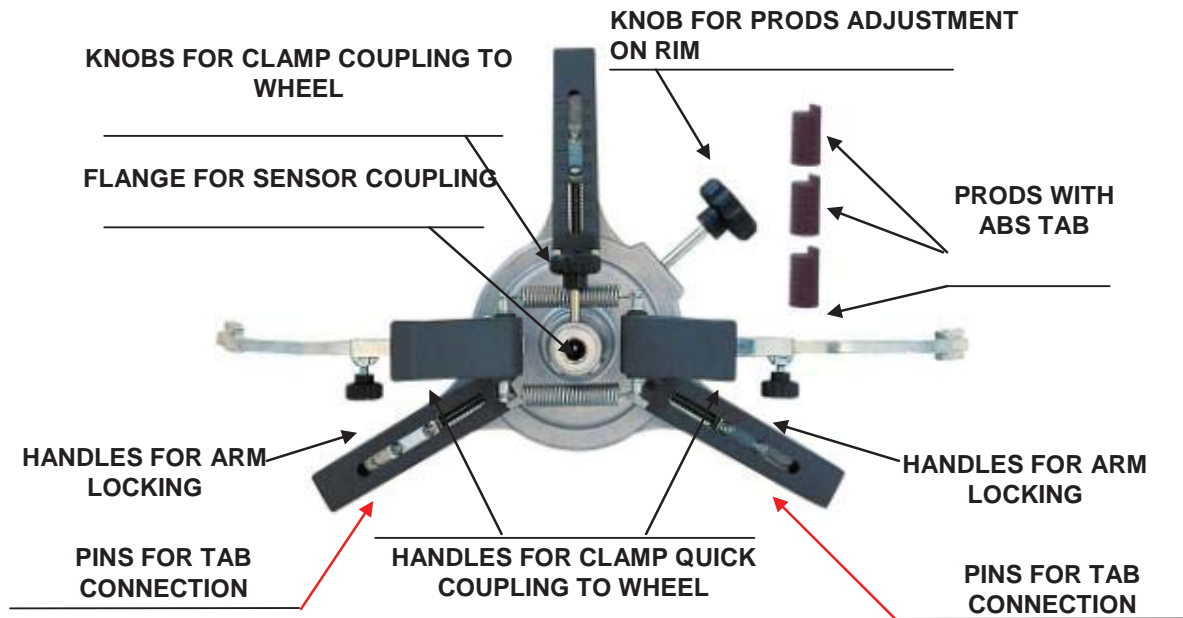

Figure 6

## 4 SWITCHING THE MACHINE ON AND OFF



**WARNING:** Before switching the machine on, make sure that the **SMART CARD** for enabling the database is in the special reader on the front of the PC.  
See chap. 10.

### 4.1 Switching the Machine On

To switch the machine on and access to the program, turn on the switch positioned on the back of the machine.

Once PC initialization is completed by the Windows operating system™, the program will be automatically enabled and the introduction page will be displayed. From this page you can enable all machine functions (see par. 8 on page 17).



Figure 7

### 4.2 Switching the Machine Off

From the introduction page (see par. 8 on page 17) you can switch the machine off by selecting the corresponding key.









	SENSOR KEYPAD	PC KEYBOARD	DESCRIPTION
			Enables machine switching off procedure request



Figure 8

	SENSOR KEYPAD	PC KEYBOARD	DESCRIPTION
			Cancels. Goes back to the introduction page. (par. 8 on page17)
			Final confirmation of machine switching off

You have to wait for the following screen to be displayed:



Figure 9

Then turn the machine off with the switch positioned on machine back side.



**WARNING:**

The switching off procedure does not affect sensor recharge ports, which continue being powered.



## 5 AUTOMATIC SENSOR SHUT OFF

When the introduction page is displayed, the system makes all sensors automatically switch off.

Sensors will automatically switch off after 5 minutes approx. if no data are received (ex. cabin is off).

It is recommended to always switch sensors manually off (see par. 3.6.3 on page 9) when they are not used.

## 6 LOW BATTERY INDICATION

System displays a low battery warning signal (Figure 10).

This signal is also visible on the sensor through the flashing of start RED LED (see par. 3.6.3 on page 9).

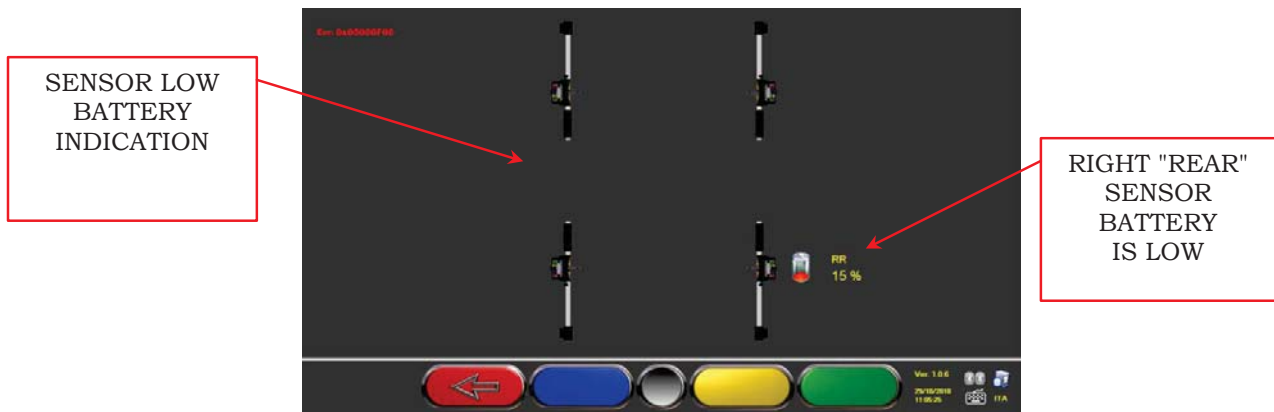



Figure 10

When the residual charge is LOWER than or EQUAL to 30%, the system displays the low battery indication page (Figure 10). The sensor will automatically switch off after a few minutes. Try not to reach this condition, and charge sensors as soon as possible.

To quit the signal page, press F1  .

## 7 PROGRAM CONFIGURATION

To proceed to program configuration, select F2  from the introduction page, as explained in par. 8.1 on page 17.

You will enter a configuration menu allowing editing the different program characteristics according to your needs.



Figure 11

**Language selection:** You can select your dialogue language among the many available ones.

**Configuration:** program will display the screen of Figure 12











You can edit system parameters, database profile, specify which parts are fitted on the machine, parts type, make a Bluetooth search to couple sensors with cabin.

**Print Menu:** Print can be customized by entering workshop data, selecting the type of desired printout, and selecting the pre-set printer (if more than one printer is connected).

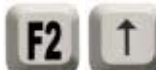
**Backup / Restore:** In order not to run the risk to lose any vehicle and customer database data, it is recommended to create a backup copy (data saving). We recommend using a "flash disk" USB key for this process.

Lost or deleted data can be restored if the backup operation has been carried out, thanks to the restore procedure.

**Additional functions:** program displays screen Figure 63, from which you can access TEST or sensor Calibration applications (reserved to skilled and authorized personnel), and the "DATABASE MANAGEMENT", see chap. 10

	SENSOR KEYPAD	PC KEYBOARD	DESCRIPTION
			Goes back to the introduction page. (par.8.1 on page17)
			Moves selection up.
			Moves selection down.
			Confirms selection.

## 7.1 DATABASE Groups Configuration

Select "GROUPS CONFIGURATION" from program configuration page, as explained in par. 7 on page 14.

You can edit system parameters, database profile, and specify which parts are fitted on the machine, and parts type as well.



Figure 12

	SENSOR KEYPAD	PC KEYBOARD	DESCRIPTION
			Goes back to the start configuration page. (par.8.1 on page 17)
			Moves selection up.
			Moves selection down.
			Confirms selection.

Select "DATABASE" option, and confirm. The following screen will be displayed:



Figure 13















	SENSOR KEYPAD	PC KEYBOARD	DESCRIPTION
			Goes back to Figure
			Moves selection up.
			Hides/displays the different Database profiles.
			Moves selection up, displaying the following profiles.
			Confirms selection.

Figure 13 displays a list, with the different DATABASE profiles, including the MAKES of the vehicles circulating in the different countries and regions all over the world.

Using key F5 , you can hide and/or display any profile so as to manage Database according to your needs.



Figure 14

By selecting any group and pressing F4, , you can also customise your profile by hiding and/or displaying the available makes, with key F5 .



Figure 15

## 8 VEHICLE DIAGNOSIS AND ADJUSTMENT

### 8.1 Introduction Page

Upon switching machine on (see par. 4.1 on page 11), program start screen will be displayed. You can select different functions.



Figure 16

	SENSOR KEYPAD	PC KEYBOARD	DESCRIPTION
			Switches machine off (par.4.2 on page 11)
			Program configuration (par. 7 on page 14)
			Accesses customer database
			Selects the list with different database profiles (par.7.1 on page 15)

Press F4 to continue.

### 8.2 Vehicle Make and Model Selection



List with different database profiles (par. 7.1 on page 15)

Figure 17



Press F4  to select vehicle make and model. Program shows the list of the makes of the selected group (see Figure 19),

Or press F5  to start a search using keys (model/make/year) or the V.I.N number (Vehicle Identification Number) which is a unique serial number used by the automobile industry to identify motor vehicles. V.I.N. consists of a 17-alphanumeric digit plate usually positioned inside engine compartment. See Figure 18.



Note: by pressing F5  you select the search mode: Through search keys such as Make name, model/year, or VIN (Figure ) or through a manual selection (Figure 19).



Figure 18

Press  to move cursor from "model name" to "V.I.N." entering field

Press  to continue, and display the list of all the vehicles complying with the just-entered search criteria; then select the correct vehicle and display the page of the selected vehicle technical specifications (par. 8.3)

To select vehicle make and model, press  from the introduction page (Figure 16) or from the database profile page (Figure 17).

The program will display the following box:

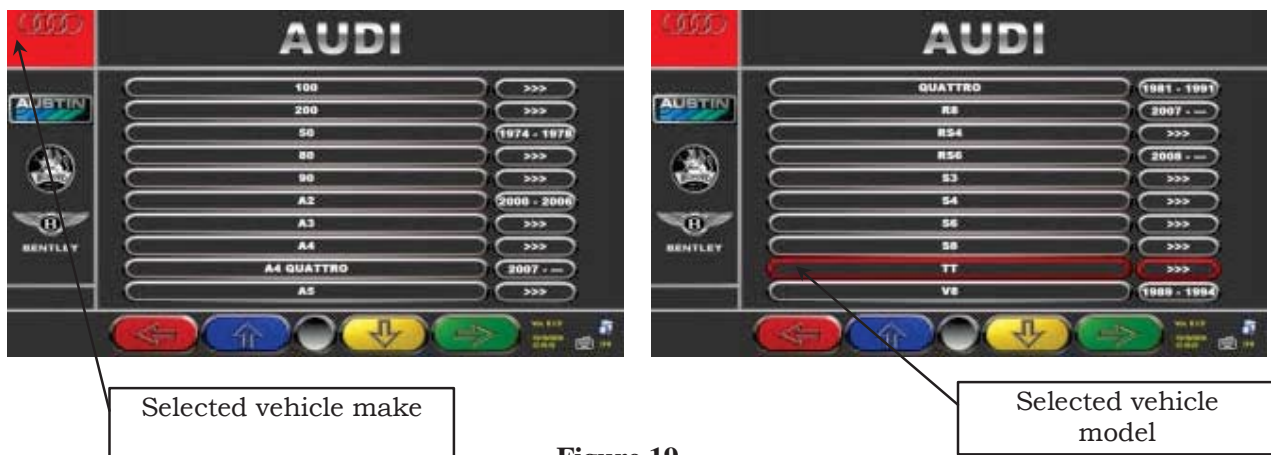

















Figure 19

Make and model of the vehicle you are going to work on shall be compulsorily selected.



	<b>SENSOR KEYPAD</b>	<b>PC KEYBOARD</b>	<b>DESCRIPTION</b>
			Goes back to the introduction page. (par.8.1 on page17)
			Moves selection up.
			Moves selection down.
			Confirms selection and goes to the following phase
			Moves selection up by one page.
			Moves selection down by one page.
			Moves selection to list top.
			Moves selection to list bottom.

**NOTE:** To speed-up selection phase, you can type the name of vehicle make or model, or part of them, on the PC keyboard, and then scroll the list until finding the desired one.

### 8.3 Selected Vehicle Technical Specification Displaying

When a vehicle is selected (see par. 8.2 on page 17), a screen showing the measurements and tolerances supplied by the manufacturer is displayed.



Figure 20

	SENSOR KEYPAD	PC KEYBOARD	DESCRIPTION
			Goes back to vehicle selection (par. 8.2 on page 17)
			See (*) Key description
			Displays vehicle technical specifications next page, and any graphic animation See (*) Key description
			Changes rim diameter value
			Goes to preliminary operations (par. 8.4 on page 21)

(\*) Key description

Possibility to enter chassis height or kingpin data, as envisaged by the manufacturer	Press F5 To display any <b>graphic animation</b>

## 8.4 Preliminary Operations

### 8.4.1 Vehicle Check Preliminary Operations

Before starting the check of vehicle geometrical alignment, the following checks shall be carried out:

- Check and, if necessary, eliminate any clearance on suspensions and on steering linkage
- Check and, if necessary, eliminate any hard spot or yielding of suspension spring parts.
- Adjust tire pressure to the values specified by the manufacturer.
- Position and distribute any load envisaged by the manufacturer.

### 8.4.2 Run-Out Preparation

After having displayed vehicle technical specification page (see par. 8.3 on page 20), you can prepare vehicle for Run-Out procedure. Proceed as follows:

- Fit clamps and sensors onto wheels
- Raise vehicle from lift platforms (if an Run-Out with raised wheel is carried out, see par. 8.5.1)
- Lock rotating plates



Figure 21

	SENSOR KEYPAD	PC KEYBOARD	DESCRIPTION
			Goes back to previous page
			Raised wheel Run-Out selection (par. 8.5.1 on page 22) or thrust Run-Out (par. 8.5.2 on page 25)
			Continues to next page (Run-Out) (par. 8.5 on page 22)

Note: during this phase, the images showing the 4 sensor batteries with the residual charge % are displayed.

## 8.5 Run-Out

The Run-Out procedure proves useful to compensate for rims and clamps unbalance. This procedure can be skipped by pressing F4.

This procedure can be enabled also after having diagnosed the vehicle, by selecting the special option from menu (see chap. 8.13 - Preliminary Operations).

To carry out the Run-Out procedure, you should have performed the preliminary operations, as explained in par. 8.4.2 on page 21.

### 8.5.1 Run-Out with Raised Wheels

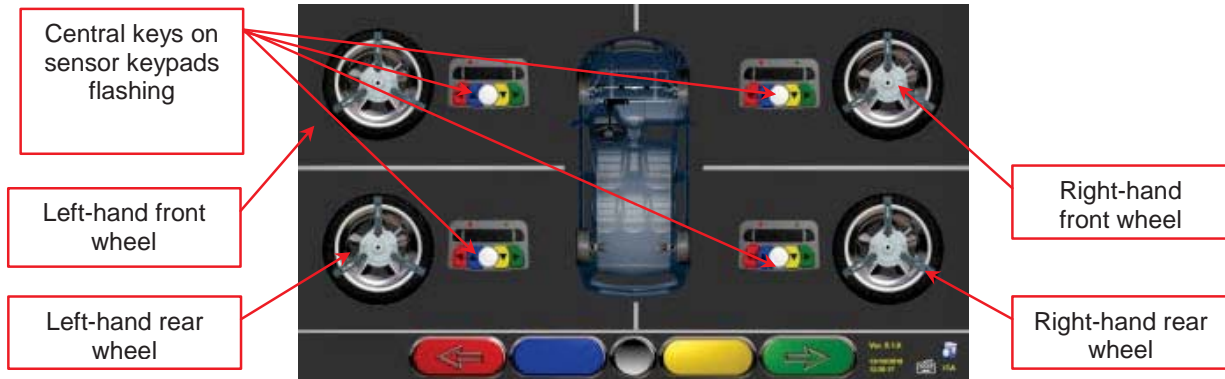







Figure 22

	SENSOR KEYPAD	PC KEYPAD	DESCRIPTION
			Goes back to Run-Out preliminary operations (par.8.4.2 on page 21)
			Make measurement preliminary operations (par 8.6. on page 30)

It is recommended to thoroughly comply with the displayed instructions.

During the start phase, the central keys of the displayed keypads are flashing, to indicate which key has to be pressed to start the procedure. It is neither necessary to start from a special wheel, nor to proceed according to a defined key order (see Figure 22).

The procedure should be carried out on all four wheels so, on the monitor, sensor keypad central keys will flash so as to suggest that you start the procedure by pressing the special key (see Figure 22). During configuration, you can set the Run-Out procedure in 2 or 3 points. The example shows a 3-point procedure.

When the keypad's central key is pressed, the following screen will be displayed:

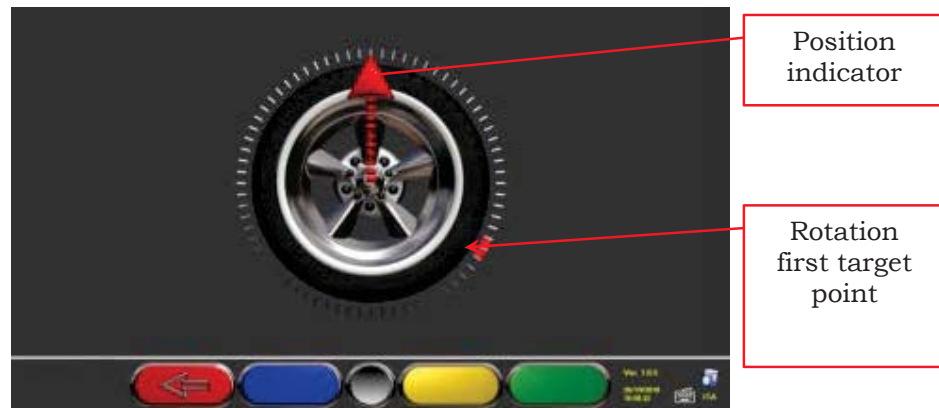

Figure 23

Figure 23 shows current wheel position.

Upon procedure start, a “self-calibration” is carried out so that the position indicator is facing up. Turn wheel rim by hand so as to allow the real-time displaying of wheel position and of the corresponding position indicator. Update is made approx. every 3 times a second. The first target is to turn wheel by 120° and reach the first highlighted point. Rotation can be made in both directions, but it is nevertheless recommended to follow the direction shown by the arrow to reach the indicated position more quickly.

Turn wheel by 120° and, once the target position is reached, press sensor keypad central key, as indicated on the screen Figure 24.



**Figure 24**

Figure 25 is displayed for approx. three seconds, which is enough for the program to acquire measurement readings. The red LED previously flashing on sensor keypad (par. 3.6.3 on page 9) will turn off during data acquisition; then it will flash again:



**Figure 25**

Now you shall turn wheel until position indicator matches the second point, positioned at about 240° from the starting position.



**Figure 26**

Turn wheel 240° and, once the target position is reached, press sensor keypad central key, as indicated on the screen Figure 24.

The last phase consists in taking the wheel back to the starting point: third point. Once the last rotation (to go back to starting position) has been carried out, the program acquires the last measurement readings. The screen Figure 25 will be displayed again for approx. three seconds. After measurement acquisition, the program will automatically continue, and the following screen will be displayed:

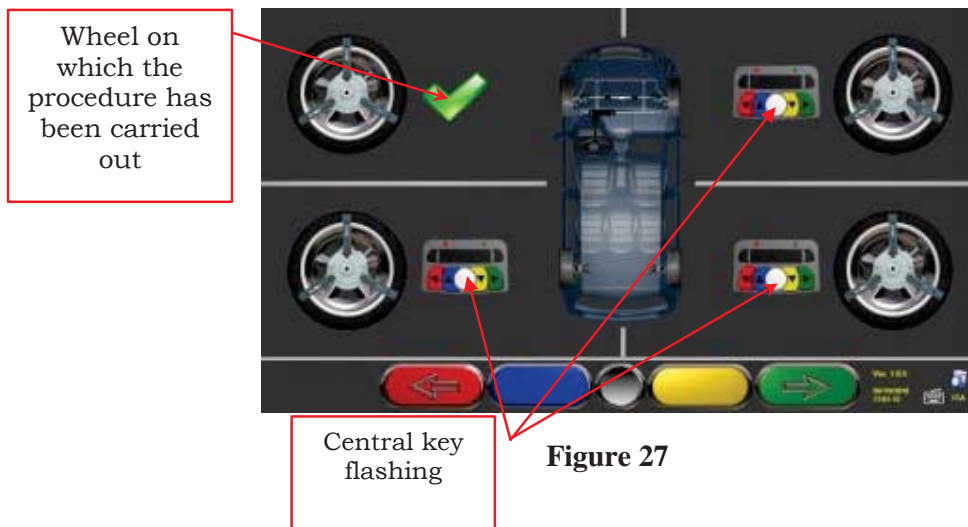

**Figure 27**

On Figure 27 the front left wheel is shown with a tick on the side, to indicate that the procedure has been carried out on that wheel. Procedure can be repeated by pressing the central key again of the concerned sensor. When the Run-Out procedure has been completed on all wheels, the program will automatically go to the next phase.

**NOTE:** Watching the monitor during this procedure can sometimes prove difficult, mainly when working on rear wheels. To prevent this problem, the Run-Out three acquisition points can be easily associated to the position of the 3 clamp arms (if made on 3 points) or to the 2 clamp sides with 4 points (if made on 2 points).



The different phases can be followed by looking at the red LED on the keypad of each sensor:  
 Red LED flashes when wheel has to be turned.  
 Red LED turns off when one of the three points is being sampled  
 Red LED is steady when the procedure has been completed.

**NOTE 2 :** During system configuration, you can also define that the procedure is carried out on 2 points instead of 3. This means that wheel will be turned twice by 180°, instead of being turned three times by 120°, as described above.

### 8.5.2 Thrust Run-Out with Automatic Acquisition

To carry out the thrust Run-Out with automatic acquisition procedure, press F3 to select

“thrust Run-Out” during the preliminary operations (see par. 8.4.2 on page 2).  
 The following screen will be displayed:

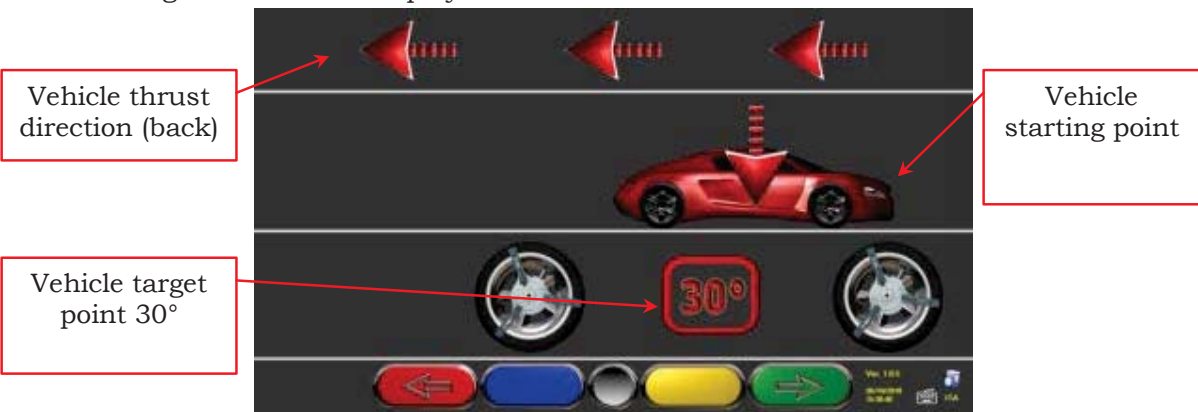

Figure 28

To carry out the thrust Run-Out operation, it is recommended to carefully follow the displayed instructions.

RELEASE sensors, so that they are free to oscillate upon wheel movement. Wait for sensors to stop oscillating, and start moving vehicle backwards, very slowly, until the rotation of the wheel has turned 30 degrees. You can observe this rotation on the 3-point races of the clamps.

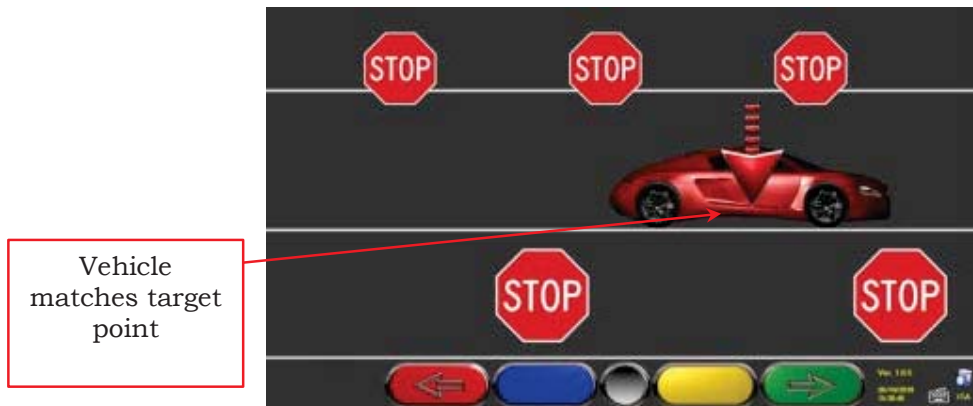
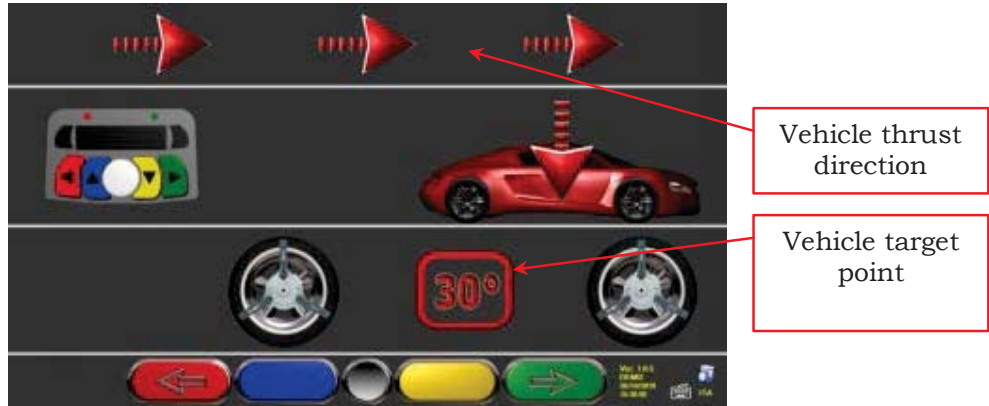

Figure 29

As soon as vehicle matches the target point, wait for sensors to stop oscillating. "STOP" will be displayed for approx. three seconds, which is enough for the program to acquire measurement readings. Then the following screen will be displayed:



**Figure 30**

Move vehicle forward again, until the rotation of the wheel did not make back 30 degrees forward (final point). "STOP" will be displayed for approx. three seconds, and measurement readings acquired. The thrust Run-Out procedure has been completed.

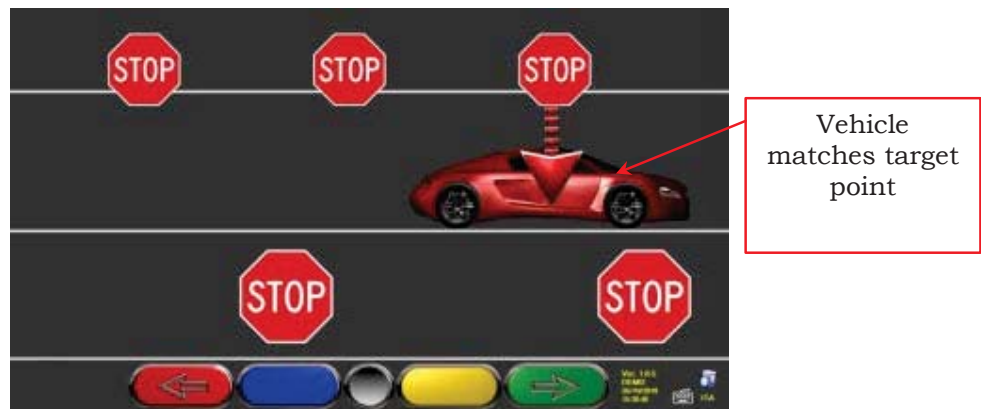

**Figure 31**

Should you wish to repeat the operation once the program has already entered a following phase, you can go back to this page by pressing F1, and repeat the above procedure. Once the Run-Out procedure has been completed, the program will automatically go to the next phase.

### 8.5.1 Inclinometer-controlled Thrust Run-Out

Inclinometer control during the thrust Run-Out procedure is used to measure more accurately the rotation angle pertaining to the calculation.

From the Run-Out configuration menu, set – Thrust Run-Out → “inclinometer”.

Lower the reference sensor (usually it is the left front one) until its end is almost touching the ground, then lock it in place. RELEASE the other sensors, so that they are free to oscillate upon wheel movement. When finished, press central key to confirm.

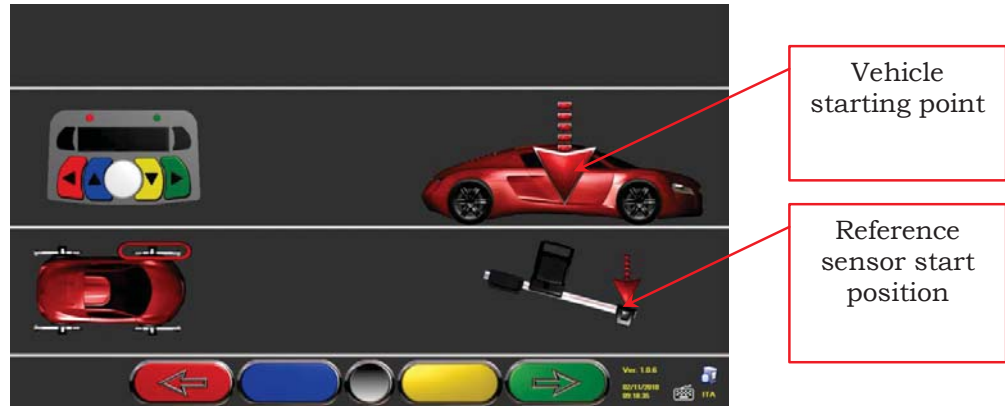

Figure 32

Move vehicle back, very slowly, until reference sensor reaches the target position (end up – see Figure 33). When finished, press central key to confirm.

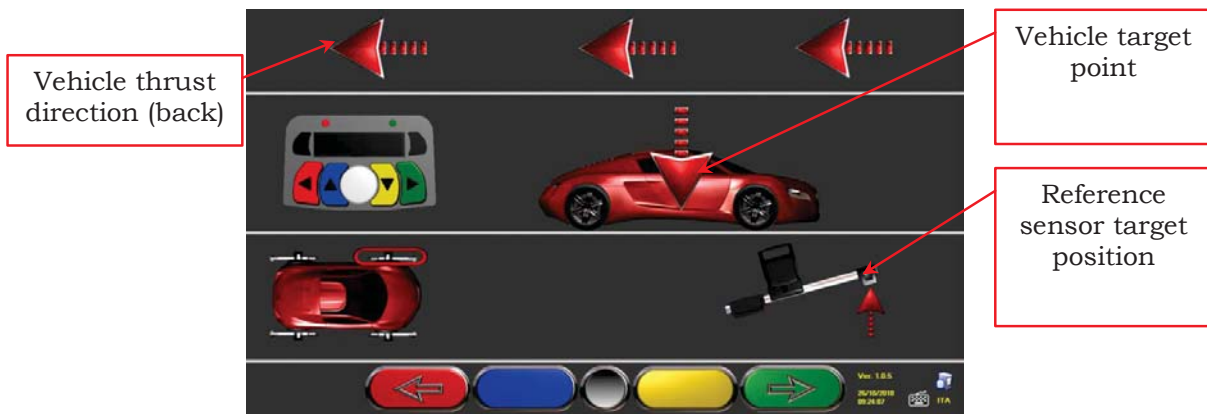

Figure 33

Position the reference sensor horizontally - clearly levelled - and, when finished, press the central key to confirm.

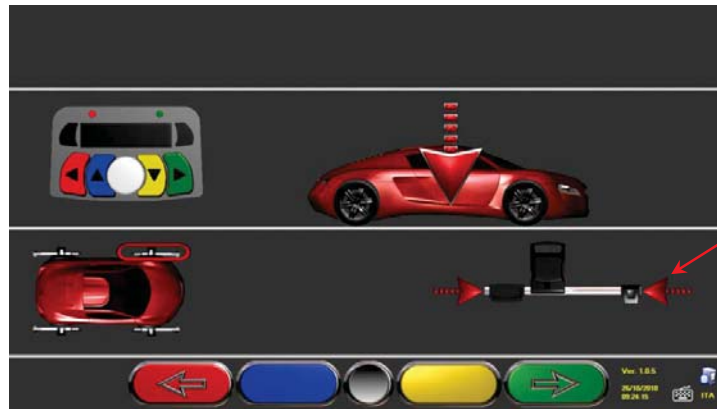

Figure 34

“STOP” is displayed for approx. three seconds, which is enough for the program to acquire measurement readings.

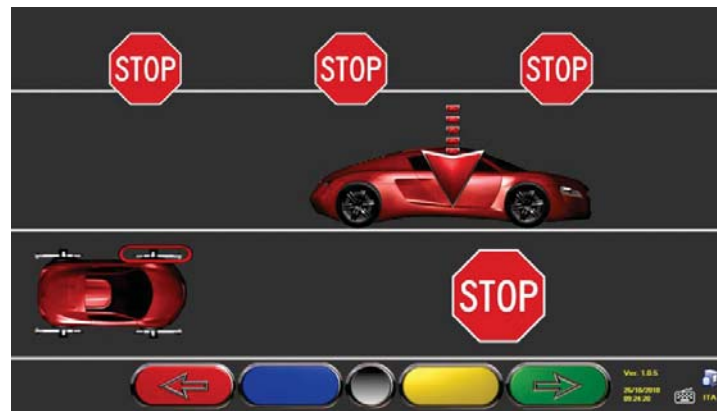

Figure 35

Position reference sensor again with the end up, almost in the "target" position reached in Figure 36 and, when finished, press central key to confirm.

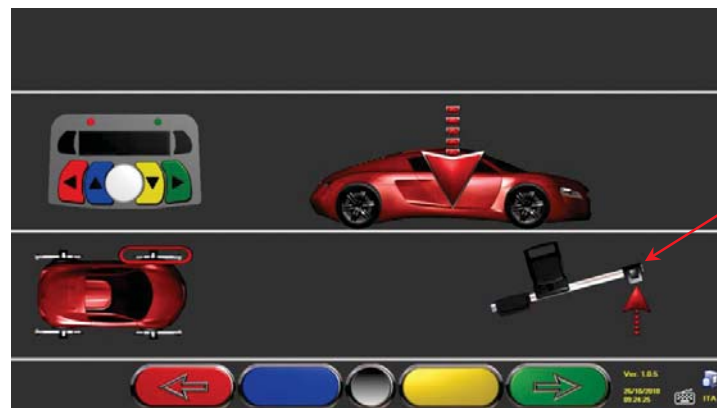
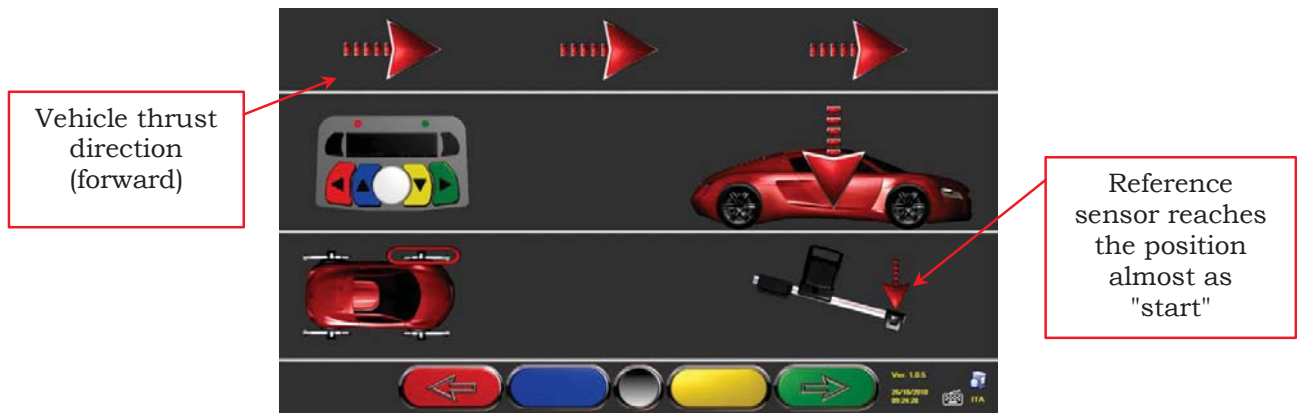

Figure 36

Move vehicle forward, very slowly, until the reference sensor again almost reaches the start position. When finished, press central key to confirm.



**Figure 37**

Position the reference sensor horizontally - clearly levelled - and, when finished, press central key to confirm. "STOP" is displayed for approx. three seconds, which is enough for the program to acquire measurement readings.



**Figure 38**

The thrust Run-Out procedure with "inclinometer control" has been carried out.

Should you wish to repeat the operation once the program has already entered a following phase, you can go back to this page by pressing F1, and repeat the above procedure. Once the Run-Out procedure has been completed, the program will automatically go to the next phase.

## 8.6 Measurement Preliminary Operations

After having carried out the Run-Out procedure as explained in par. 8.5 on page 22, the vehicle is prepared for measurement readings. The following screen will be displayed:



Figure 39

	SENSOR KEYPAD	PC KEYBOARD	DESCRIPTION
			Goes back to Run-Out procedure (par. 8.5 on page 22)
			Continues to the alignment procedure (par. 8.7 on page 31)

- 1) Lower vehicle so as to make wheels rest on lift platforms (of course, only if the Run-Out procedure has been carried out with raised wheels)
- 2) Release front plates, and any rear platform
- 3) Brake wheels with hand brake, and lock brake pedal with the special tool (this operation is necessary when carrying out a steering for kingpin correct calculation).
- 4) Settle vehicle front and rear ends (this operation shall be carried out only if the Run-Out with raised wheels procedure has been performed).

Press to continue.





## 8.7 Sensors Alignment and Levelling

To proceed to the sensor alignment and levelling procedure, you should have first carried out measurement preliminary operations, as explained in par. 8.6 on page 30.



Figure 40

	SENSOR KEYPAD	PC KEYBOARD	DESCRIPTION
			Goes back to measurement preliminary operations. (par. 8.6 on page 30)

Turn steering wheel from left to right, or vice-versa, until wheels are aligned, namely until display level is not perfectly centered.

Adjust sensors until they are levelled, and lock them in place by turning the special knobs. This operation shall be carried out on all four sensors.

Rear sensors also feature special 3-LED indicators (par. 3.6.44 on page 9) flashing based on sensors levelling.

If front wheels are too misaligned, no levelling will be displayed.

NOTE: Once sensor alignment and levelling operations are completed, the “STOP” images will be displayed under the alignment level to indicate that the program is acquiring vehicle data measurements. Sensor calibration check is also carried out. Program will automatically continue only after sensors are correctly aligned and levelled.

WARNING: The vehicle being diagnosed could feature a front spoiler preventing communication among sensors. Should this be the case, the special “spoiler” procedure will be automatically started.

Follow the displayed graphic representation, and lower front sensors so that the transducers positioned onto arm end are below the spoiler. System acquires front toe measurement, and then the alignment and levelling procedure of Figure 3 will be displayed again. Align and level, the program will continue automatically.

## 8.8 Steering Procedure

Once sensors are aligned and levelled (see par. 8.7 on page 31), the steering procedure can be carried out in order to define:

- Caster
- Kingpin
- Included angle

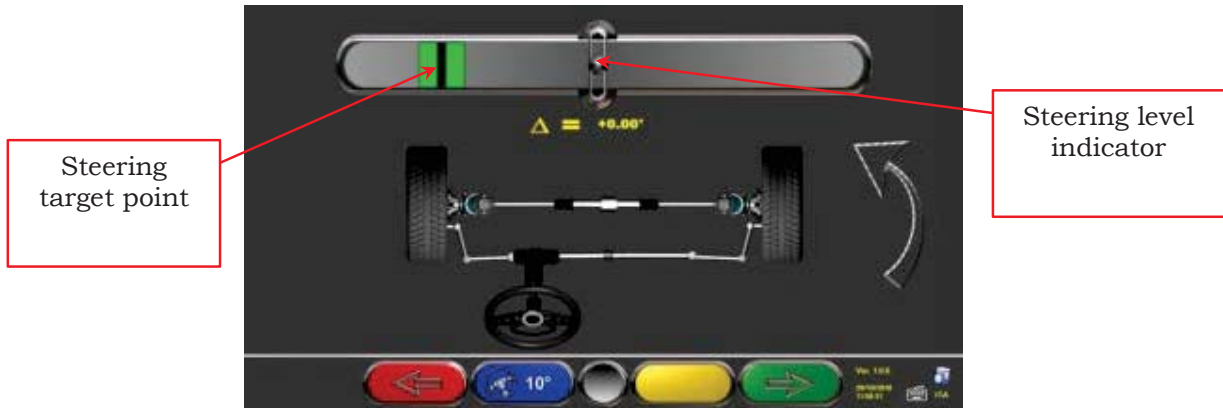

Figure 41

	SENSOR KEYPAD	PC KEYBOARD	DESCRIPTION
			Repeat alignment and levelling procedure (par. 8.7 on page 31)
			Press this key to select the type of steering to be made. (*)
			Displays vehicle diagnosis page (par. 8.9 on page 33)

(\*) Type of steering to be made:

- Steering at 20°
- ACK steering (at 20° with Toe-out on turn)
- Steering at 10°
- Max. steering with rotating plates with ENCODER (optional)

Steering procedure can also be skipped: the values of the above-specified data measurements will not be available. To skip the procedure, press F4 to directly display vehicle diagnosis page.

Should the procedure not be carried out at this stage but only at the end of adjustments, you can select the corresponding option from the menu.

## 8.9 Vehicle Diagnosis

After having carried out the steering procedure (see par. 8.8 on page 32), a diagnosis page showing a summary of the operations carried out on vehicle rear axle (Figure 42) will be displayed.



Figure 42

	SENSOR KEYPAD	PC KEYBOARD	DESCRIPTION
			Repeat steering procedure. (par. 8.8 on page 32)
			Changes values displaying layout
			Displays vehicle technical specifications (it may be changed, if needed). (par. 8.3 on page 20)
			Displays diagnosis page with a summary of front axle measurements (Figure 43)

Press F4 to display the diagnosis page with a summary of front axle measurements (Figure 43). If you press F3 from here , the program will allow the printout of diagnosis measurements.

Press F4 to continue with data adjustment, the program will display Figure 4, press F4 again to confirm.



Figure 43



Figure 44

Now you can prepare vehicle for adjustment (see par. 8.10 on page 34), confirm with F4 (Figure 44).

## 8.10 Adjustment Preliminary Operations

Select F4 from Figure (see par. 8.9 on page 33) to carry out adjustment preliminary operations. Follow the displayed instructions to carry out adjustment preliminary operations. Press F4 to continue.

1. Place steering wheel in straight position.
2. Lock steering wheel with the special tool, and continue.



Figure 45

## 8.11 Rear Axle Adjustment

Rear axle adjustment procedure can be made by pressing F4 from Figure 45 after having carried out adjustment preliminary operations (par. 8.10).

Proceed to adjustment, where allowed, as follows:

- Rear camber - Rear partial toe



Figure 46

	SENSOR KEYPAD	PC KEYBOARD	DESCRIPTION
			Changes values displaying layout (large numbers/large cursors)
			“Jack-Hold” procedure (adjustment with raised wheels)
			Displays vehicle technical specification page. (par. 8.3 on page 20)
			Continues to front axle adjustment. (par. 8.12 on page 35)

## 8.12 Front Axle Adjustment

Front axle adjustment procedure is launched by selecting in the rear axle adjustment page (Figure 47) after having carried out adjustment preliminary operations (see par. 8.10 on page 34).

To adjust angles, the correct sequence is the following: CASTER – CAMBER – TOE.

**WARNING:** When entering this stage, caster values are “FROZEN”.

To “de-freeze” these values, you can press Shift+F5 at the same time when the measurement selection “R” is on caster measurement values, or select F2 to display a menu page with additional functions (par. 8.13 on page 36). Now select “Caster Adjustment”.

Once caster values have been adjusted or, even if they are not adjusted as they are deemed to be correct, it is recommended to “FREEZE” these values again. This procedure prevents caster values from varying in case sensors are inadvertently moved.















To this end, take measurement selection “R” (see Figure 47) onto the caster values, and proceed as described above.

A grid will be displayed onto caster values, to indicate that they are “frozen”.

Then adjust front axle



Figure 47

	SENSOR KEYPAD	PC KEYBOARD	DESCRIPTION
			Repeat steering procedure. (par. 8.8 on page 32)
			Displays options menu. (par. 8.13 on page 36)
			Selection key of the measurement to be adjusted.
			Operations completed ! Customer data entry (par. 8.14 on page 37)
			Repeats adjustment operations (par. 8.11 on page 34)



### 8.13 Additional Functions Menu

To carry out some additional operations or to repeat some of program phases (in case they have not given satisfactory outcomes or have not been carried out at all), select F3 from the FRONT AXLE ADJUSTMENT page (see par. 8.12 on page 35).



You will access an additional function menu allowing carrying out the following procedures:

**PRELIMINARY OPERATIONS:** see par. 8.4.1 on page 21.

**TOE CURVE:** Toe curve can be adjusted by following the displayed figures, as follows:

- Settle vehicle, press F4
- Position the special tool under front axle, press F4
- Adjust front partial toe, as recommended by the manufacturer, press F4
- Remove tool from axle, and press F4. Program will go back to the adjustment phase.

**CHASSIS DIAGNOSIS:** A graphic-geometrical representation of the axles of the vehicles you are working on can be displayed.

**DATABASE:** Displays vehicle selection page (8.2 on page 17) and, if needed, selecting a different vehicle

**CASTER ADJUSTMENT:** see par. 8.12 on page 35.



Figure 48

	SENSOR KEYPAD	PC KEYBOARD	DESCRIPTION
			Goes back to front adjustment page (par 8.12 on page 35)
			Moves selection up.
			Moves selection down.
			Confirms selection.

## 8.14 Printout of Measurements taken

By selecting the following key from the customer data entry page, the following screen will be displayed:



the following screen will be displayed:













Vehicle and customer data entry

Figure 49

	SENSOR KEYPAD	PC KEYBOARD	DESCRIPTION
			Repeat steering procedure. (par. 8.8 on page 32)
			Stores the carried out diagnosis inside a special "customer database" so as to allow test later displaying (par. 8.13 on page 36)
			Displays a print preview of the test carried out (Figure 50)
			Goes back to start page without storing test

Figure 50



	<b>SENSOR KEYPAD</b>	<b>PC KEYBOARD</b>	<b>DESCRIPTION</b>
			Goes back to “vehicle data entry” phase of Figure
			Allows selecting a printer different from the pre-set one
			Sends print report to printer
			Allows defining colors on the printout of out-of-tolerance data (Red to highlight them or Black NOT to highlight them)

A report on the performed test is printed with customer data, vehicle data before and after adjustment, vehicle technical specifications supplied by manufacturer, and any other remarks for the customer.

To access the data contained inside customer database, press F3  from the start page (see Figure 16)

Legend of the printout example shown in the previous page (Figure 51).

- 1 - Logo of the manufacturer
- 2 - Space dedicated to workshop data customisation
- 3 - Test date and time
- 4 - Vehicle being tested and vehicle owner data
- 5 - Vehicle being tested manufacturing data
- 6 - Vehicle being tested diagnosis data
- 7 - Vehicle being tested data after adjustment
- 8 - Front axle data table
- 9 - Rear axle data table
- 10 - Space devoted to manual remarks



**Greg Smith Equipment Sales, Inc.**  
 5800 Massachusetts Avenue  
 Indianaapolis, IN 46218

4  
 8  
 9  
 10  
 1  
 2  
 3  
 Data : 04/10/2010 13:42  
 ---  
 Modello : A5 SPORTBACK (PR=IBA/E/L) (2009 - ----)  
 Diam. cerchio 19"

Cliente : ROSSIO MARIO  
 Targa : BJ073LM  
 Marca : AUDI  
 Km : 22305

**Asse anteriore**

	Valori nominali	Diagnosi	Registrazione
Convergenza tot.	Gr +0°10' +0°20' +0°30'	+1°01'	+0°58'
Semiconverg. ant	Gr +0°05' +0°15'	+0°34'	+0°29'
Incl. ruota ant.	Gr -1°28' -1°05' -0°42' ---	+0°44'	-1°12' +0°31' +0°41'
Incidenza mont.	Gr -----	-----	-----
Incl. montante	Gr -----	---	---
Angolo incluso	Gr -----	---	---
Diverg. in curva (20°)	Gr +1°19' +1°49' +2°19' ---	-----	-----
Sierzata interna	Gr +37°06' +39°36' +41°06'	---	---
Sierzata esterna	Gr +31°02' +33°12' +34°42'	---	---

**Asse posteriore**

	Valori nominali	Diagnosi	Registrazione
Convergenza tot.	Gr +0°00' +0°20' +0°30'	+0°22'	+0°19'
Semiconverg. post	Gr +0°05' +0°10' +0°15'	+0°12'	+0°10'
Incl. ruota post.	Gr -1°48' -1°20' -0°55' ---	-0°04'	-0°23' +0°19' +0°31'
Angolo di spinta	Gr -0°15' +0°00' +0°15'	+0°01'	+0°00'

Figure 51

## 9 DATABASE CUSTOMIZATION

Vehicle database can be customized by creating customized groups and vehicles.

### 9.1 New Group Entry

To create customized groups and store them inside database, the group configuration page shall be displayed (see par. 7.1 on page 15).

Press “Ins” on the keyboard .

The following screen will be displayed:



Figure 52

Type the name of the new profile (the example Figure 2 shows “ITALIA”), and press F4 to confirm.



Figure 53

Now press F4 to enter the new “ITALIA” group and display the available makes with F5 , as specified in Figure 53. Then display profile, always pressing F5, as described here below in Figure 54.

Press F1 to quit.

By selecting "All makes" group using F5, a profile where all the vehicles of all the makes included in the database will be displayed

New displayed group



Figure 54

## 9.2 New Group Deletion

You have to display the group configuration (see par. 7.1 on page 15), select the customized group you want to delete, then press "cancel"  : , and press F4 to confirm.



Displayed customized group

Figure 55

**Warning:** If a customized group is deleted, it will no longer be possible to restore it, unless you have a database backup copy.

### 9.3 New Vehicle Entry

To create customized vehicles and store them inside the database, you shall first of all display the page of the measurements and tolerances supplied by the manufacturer of an already-existing vehicle (see par. 8.3 on page 20).

Press “Ins” on the keyboard :  
The following screen will be displayed:





**Figure 56**

As you can see in Figure 56 on the highlighted point, the make of the selected vehicle is highlighted by a red background.



You can enter or confirm the name of the make of the vehicle you want to create. Then, select and enter:

- Vehicle model and submodel name
- Manufacturing start date
- Manufacturing end date
- Rim diameter
- Front track
- Rear track
- Left wheelbase
- Right wheelbase
- Load conditions
- Tank conditions

Use the following keys for data selection:

	Move selection to the following datum.
	Move selection to the previous datum.

After data entry, you can delete them using the following keys:

	Deletes the whole selected element
	Deletes the last character of the selected element

Once the manufacture end date has been entered and you move on the next datum, the following screen relating to load conditions will be displayed





Figure 57

After having selected rim diameter, the following data to be entered are vehicle track and wheelbase, in the following screen:



Figure 58













Then enter tank and load conditions  
Now the screen will look as follows:







Highlighted point

Figure 59



	SENSOR KEYPAD	PC KEYBOARD	DESCRIPTION
		 	Goes back to the introduction page. (see chap. 8 on page 17)
		 	Moves selection up.
		 	Moves selection down.

As you can see from the zoom on the right side of Figure 59, you will have to specify if the point datum refers to can be adjusted or not.

	The point to which the data refers to can be adjusted. To define it as not-adjustable, press:	
	The point to which the data refers to cannot be adjusted. To define it as adjustable, press:	
Once the desired option has been selected, press:		



Once angle “adjustability” has been specified, you can enter the **graphic animations**.

Select the correct image or animation with keys   , then press “Enter” to confirm 

Now you may enter vehicle standard tolerance values as for:

FRONT AXLE:	REAR AXLE
<ul style="list-style-type: none"> <li>• Toe</li> <li>• Camber</li> <li>• Caster</li> <li>• Kingpin</li> <li>• Included angle</li> <li>• Max. steering</li> </ul>	<ul style="list-style-type: none"> <li>• Toe</li> <li>• Camber</li> <li>• Thrust angle</li> </ul>

Select data as described above, and enter values.

Warning: To separate whole values from decimals, try using a “dot”  or a “comma” .

When you have completed entering values, the following screen will be displayed. You will have to select an option:



Figure 60

Press F4  to confirm and create the customized vehicle.

If vehicle database is displayed, you can observe that the just-created customized vehicle is present; it is listed under a separate make, in alphabetical order, written in italic.

Using the same procedure, you can edit the values of a customized vehicle without having to create a new one. The final screen will be like the one of Figure with the additional item:

“Edit customized vehicle”

Select this option to edit vehicle data.

## 9.4 Customized Vehicle Deletion

You have to display vehicle database, and select the customized vehicle you wish to delete,

then press Ctrl + Canc:  + 

Warning: If a customized vehicle is deleted, it will no longer be possible to restore it, unless you have a database backup copy.

## 10 PROGRAM AND DATABASE PROTECTION SMART CARD

Atlas Edge 401 and Edge 601 aligners feature a PC with SMART CARD reader. This SMART CARD, inserted inside the reader, allows program operation, and enables access to the vehicle DATABASE.

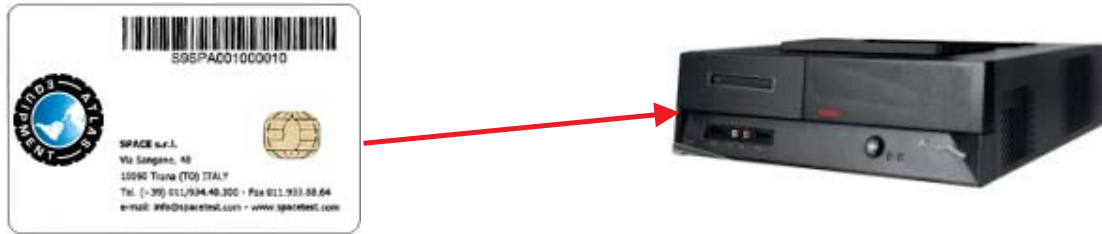

Figure 61

Every machine has its own unique SMARTCARD that cannot be replaced with the SMARTCARD of another machine for whatever reason. Should this SMARTCARD be removed or replaced, the program will display an error message, such as Figure 62, and will not give the authorization to continue.



Figure 62

The database can be updated by downloading files from Internet. Contact your retailer for further details on the download from the manufacturer's web site.

### 10.1 DATABASE Management

To update the database, proceed as follows:  
Select "Database Management" option from program configuration menu (see chap. 7) as specified in Figure 63, and press F4 to continue.



Figure 63



SMARTCARD  
serial number

**Figure 64**



When a USB flash disk key is inserted (such as the one supplied with the machine, and containing system Back-Up), the keys for database management are displayed, as shown in Figure 65.



SMARTCARD  
serial number

F2 → EXPORT  
CERTIFICATE

USB FLASH DISK  
DETECTED

F3 → IMPORT  
TOKEN  
(release key)

F4 → IMPORT  
Database on PC

**Figure 65**

F2  → Export certificate on USB flash disk. Customer shall send it to the manufacturer so that a release key can be prepared (as an alternative to the communication of customer's SMARTCARD serial number).

F4  → Allows copying the correct path of the DATABASE file that has been previously downloaded from internet and inserted inside the USB flash disk ROOT. Updated databases shall then be released through "Token" import.

F3  → Manufacturer sends the release code (called Token) to the customer after having checked the fulfilment of requirements (such as payment of the new Database). This "Token" file shall be pasted inside the USB flash disk ROOT and, by selecting this key, Token is imported in the correct path on your own PC so that the new database is released.

## 11 SENSOR ERRORS

### 11.1 Data Reception/Transmission Error between Sensors and Cabin

During data transmission/reception between sensors and cabin, the following screen may be displayed:

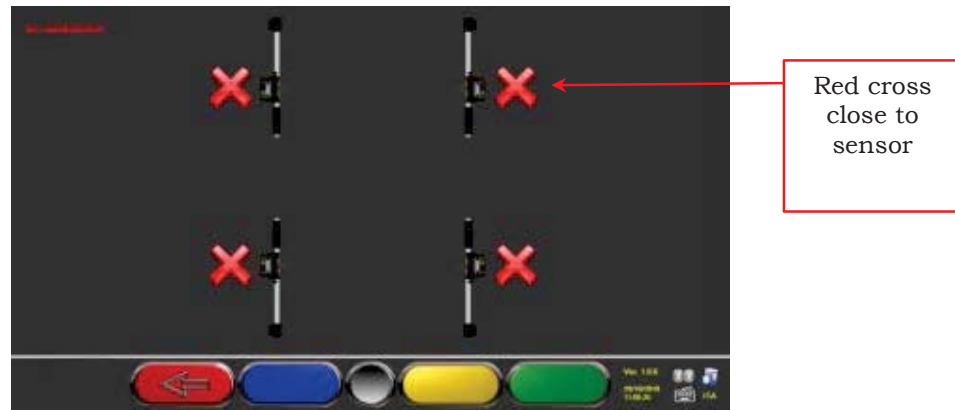

**Figure 66**

This means that there is a transmission/reception failure due to one or several of the following problems:

- Sensors infrared transceivers are not working
- There is a failure or a radio interference inside the transmission system,
- There is a hinder (ex. vehicle door open) between front and rear sensors.

Rear sensors do not directly communicate with cabin: their data are transmitted/received passing through front sensors so, if a front sensor is not working properly, data could not be transmitted to the corresponding rear sensor, even if the latter is working.

If the cause of failure is eliminated (ex. vehicle door is closed) error page will immediately disappear, and the measurement page will be displayed again. If the problem continues, check system hardware by switching machine off. Of course, it is not recommended to abruptly power cabin off; follow the correct switching off procedure:

- Press “Esc” on keyboard to go back to the introduction page (chap. 8 on page 17).
- Switch machine off following the correct procedure (see par. 4.2 on page 11).

### 11.2 Angle Measurement Horizontal Error

The following screens may be displayed during infrared data measurement:

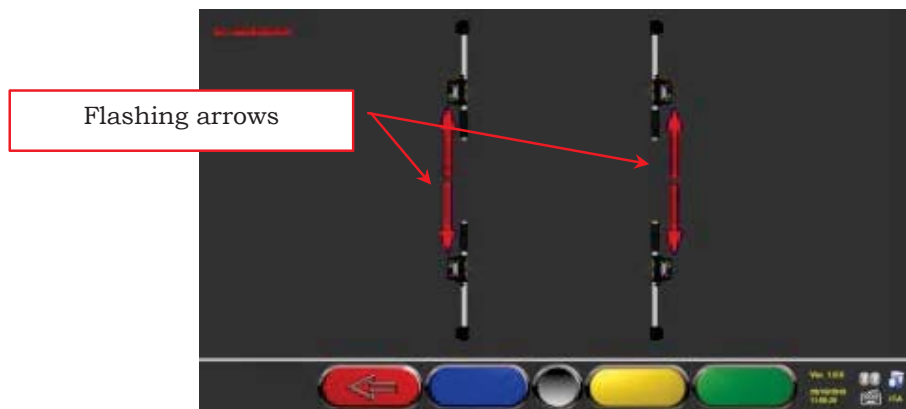

**Figure 67**

This error page indicates that one or more horizontal infrared measurements cannot be carried out.

There may be several causes:

- One or more CCD sensors (digital infrared transducer for horizontal angle measurement) are not working.
- One or more infrared emitters for horizontal angle measurement (I.R. LED) are not working.
- There is a hinder (ex. vehicle door open) between front and rear sensors.

If the cause of failure is eliminated (ex. vehicle door is closed) error page will immediately disappear, and the measurement page will be displayed again. If the problem continues, check system hardware by switching machine off. Of course, it is not recommended to abruptly power cabin off; follow the correct switching off procedure:

- Press “Esc” on keyboard to go back to the introduction page (see chap. 8 on page 17).
- Switch machine off following the correct procedure (see par.4.2 on page 11).

## 12 TROUBLESHOOTING

Some of the most common problems that could arise on wheel aligners are listed here below. Atlas Equipment declines all liability for injury or damage to persons, animals and properties caused by the intervention of unauthorised personnel, and by the use of non-original spare parts.

Before doing any operation on the system, always disconnect the power supply.

In case of doubt, do not interpret, but contact Atlas Equipment technical assistance in order to obtain instructions suitable for performing operations in total safety.

TROUBLE	CAUSE	REMEDY
NO OPERATION	- No mains voltage - Interrupted protection fuses	- Check mains voltage - Check protection fuses
Monitor does not work	- No supply voltage - No video signal	- Check power cable connection - Check video signal cable connection between PC and monitor
PC cannot be switched on	- No supply voltage	- Check PC ON/OFF switch - Check power cable connection
Printer does not work (see also printer user's manual)	- No supply voltage - No signal	- Check ON/OFF voltage - Check power cable connection - Check printer signal cable connection with PC

## 13 MAINTENANCE

**WARNING!** Before doing any maintenance job, the machine will have to be disconnected from the power mains.

To clean plastic panels or surfaces use alcohol (AVOID USING LIQUIDS CONTAINING SOLVENTS).

DISPLAY should be cleaned with a dry cloth; if very dirty, clean it with a moist cloth, then dry it.

Do not spray the alcohol directly on the control panel and do not clean using strong jets of compressed air.

Keep optical unit methacrylate filters clean using a slightly moist cloth, do not use solvents;

Printer cleaning, cartridge replacement and any other maintenance operation on printer are described in the manual supplied with the printer itself. Always refer to this manual before carrying out any maintenance operation on printer.





## 14 STORAGE AND SCRAPPING

**Storage** - If the machine has to be stored for a long period of time, disconnect all supply lines and protect the display screen, which could be damaged by excessive dust. Grease any parts liable to be damaged by dryness.

**Scrapping** - If the machine is to be no longer used, it must be made inoperative: All those parts that could represent a potential hazard risk must be correctly disposed of. Dispose of parts according to category. Scrap as iron scrap through authorised channels. Parts considered as special waste must be removed and split up according to type and then disposed of through authorised channels according to applicable regulations.

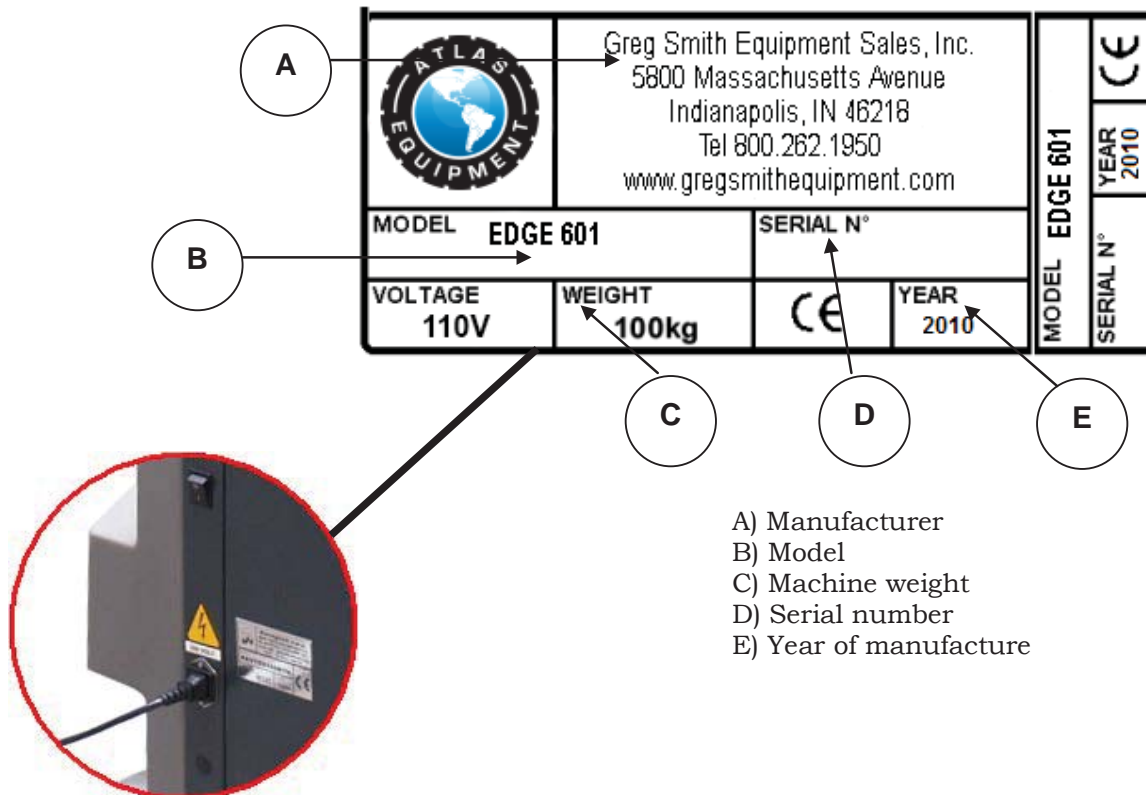
## 15 MACHINE IDENTIFICATION DATA



		Greg Smith Equipment Sales, Inc. 5800 Massachusetts Avenue Indianapolis, IN 46218 Tel 800.262.1950 www.gregsmithequipment.com		MODEL EDGE 601	SERIAL N°	MODEL EDGE 601	YEAR 2010	SERIAL N°	CE
VOLTAGE 110V		WEIGHT 100kg							

A) Manufacturer  
 B) Model  
 C) Machine weight  
 D) Serial number  
 E) Year of manufacture

**WARNING:** It is strictly forbidden to tamper with, notch, somehow alter or even remove machine identification plate; do not cover it with temporary panels, etc... as it shall always be clearly visible.

Said plate must always be kept clean.

**CAUTION:** Should the plate be accidentally damaged (removed from the machine damaged or even partially illegible) inform immediately the manufacturer.