

20 TON

AIR/MANUAL SHOP PRESS

Instruction Manual

Please read this instruction manual carefully before use.

IMPORTANT

PLEASE READ THESE INSTRUCTIONS CAREFULLY. NOTE THE SAFETY INSTRUCTIONS AND WARNINGS. USE THE PRODUCT CORRECTLY AND WITH CARE FOR THE PURPOSE FOR WHICH IT IS INTENDED. FAILURE TO DO SO MAY CAUSE DAMAGE TO PROPERTY AND/OR SERIOUS PERSONAL INJURY. PLEASE KEEP THIS INSTRUCTION MANUAL SAFE FOR FUTURE USE.

1. SAFETY INSTRUCTIONS AND WARNINGS

- 1.1 Use a qualified person to maintain the press in good condition. Keep it clean for best and safest performance.
- 1.2 The maximum load is 20tons. **DO NOT** exceed this rated capacity. Never apply excessive force to a workpiece and always use the pressure gauge to accurately determine the applied load.
- 1.3 Use this press for the purpose for which it is intended. **DO NOT** use it for any other purpose it is not designed to perform.
- 1.4 Keep children and unauthorized persons away from the work area.
- 1.5 Remove ill fitting clothing. Remove ties, watches, rings and other loose jewelry, and contain long hair.
- 1.6 Wear ANSI approved impact safety goggles, full-face impact safety shield and heavy-duty work gloves when operating the press.
- 1.7 Keep proper balance and footing, do not overreach and wear nonskid footwear.
- 1.8 Only use this press on a surface that is stable, level, dry and not slippery, and capable of sustaining the load. Keep the surface clean, tidy and free from unrelated materials and ensure that there is adequate lighting.
- 1.9 Inspect the press before each use. **DO NOT** use if bent, broken, cracked, leaking or otherwise damaged, any suspect parts are noted or it has been subjected to a shock load.
- 1.10 Check to ensure that all applicable bolts and nuts are firmly tightened.
- 1.11 Ensure that workpiece is center-loaded and secure.
- 1.12 Keep hands and feet away from bed area at all times.
- 1.13 **DO NOT** use the shop press to compress spring or any other item that could disengage and cause a potential hazard. Never stand directly in front of loaded press and never leave loaded press unattended.
- 1.14 **DO NOT** operate the press when you are tired or under the influence of alcohol, drugs or any intoxicating medication.
- 1.15 **DO NOT** allow untrained persons to operate the press.
- 1.16 **DO NOT** make any modifications to the press.
- 1.17 **DO NOT** use brake fluid or any other improper fluid and avoid mixing different types of oil when adding hydraulic oil. Only good quality hydraulic jack oil can be used.
- 1.18 **DO NOT** expose the press to rain or any other kind of bad weather.
- 1.19 If the press needs repairing and/or there is any part that needs to be replaced, have it repaired by authorized technicians and only use the replacement parts supplied by the manufacturer.
- 1.20 **WARNING:** the warnings, cautions and instructions discussed in this instruction manual cannot cover all possible conditions and situations that may occur. It must be understood by the operator that common sense and caution are factors which cannot be built into this product, but must be supplied by the operator.

2. SPECIFICATIONS

Capacity	20ton	Stroke	190mm (7-1/2")
Working Range	0-988mm (0-38-7/8")	Bed Width	545mm (21-1/2")
Air Inlet Fitting	1/4" NPT	Air Pressure	120-200PSI

3. ASSEMBLY

Use the exploded drawing as your guide to assemble the press. Lay all parts and assemblies out in front of you before beginning. The following procedure is recommended:

- 3.1 Attach one base section (21) to left post (20) and lower cross member (26) using bolts (25), washers (22), lock washers (23) and nuts (24), then attach another to right post (20) and the lower cross member (26).
- 3.2 Put the press frame in an upright position, attach one upper crossbeam (10) to left and right posts (20) using bolts (9), washers (13), lock washers (12) and nuts (11).
- 3.3 Put another upper crossbeam into position and insert the under plate (7) to the two upper crossbeams at the same time, then secure this crossbeam to the posts with bolts (9), washers (13), lock washers (12) and nuts (11).
- 3.4 Screw the upper round nut (6) onto the ram (3), insert the ram into the hole in the under plate (7), then screw the under round nut (8) onto the ram and attach the serrated saddle (5) to the ram.
- 3.5 Join the two press bed frame (18) together by inserting the four bolts (27) through the bushings (28) and the holes in the bed frames, then secure the four bolts by tighten the washers (14), lock washers (15) and nuts (16) on it.
- 3.6 Insert bed frame pins (19) into the holes in the posts, then insert the joined press bed frame (18) into press frame and onto bed frame pin.
- 3.7 Attach the pump and air motor assemblies to the right post using bolts (29) and washers (14), then insert the jack handle (48) into the handle bracket (38).
- 3.8 Connect the hydraulic hose fitting (57) to the connection nut (58) and assemble the pressure gauge (1) to the pressure gauge connection nut (59) which is on the top of the ram (3).
- 3.9 Tighten all bolts and nuts.

4. BEFORE FIRST USE

- 4.1 Before first use of this product, pour a teaspoon of good quality, air tool lubricant into the air supply inlet of the lift control valve, connect to air supply to air supply and operate for 3 seconds to evenly distribute lubricant.
- 4.2 Purge away air from the hydraulic system.

Manual operating system: open the release valve (41) by turning it counterclockwise. Pump several full strokes to eliminate any air in the system.

Air operating system: open the release valve (41) by turning it counterclockwise. Connect the air inlet fitting (39) into the air supply hose lock fitting, then turn on the air valve (40) letting the pump work for several times to eliminate any air in the system.

4.3 Check all parts and conditions, if there is any part broken, stop using it and contact your supplier immediately.

5. OPERATING INSTRUCTIONS

WARNING! Ensure that you read, understand and apply the safety instructions and warnings before use.

WARNING! Ensure that you have familiarized yourself thoroughly with the product and the hazards associated with its improper use.

- 5.1 Place the heel block (17) onto the press bed frame (18), then insert workpiece onto the heel block.
- 5.2 Close the release valve (41) by turning it clockwise until it is firmly closed.
- 5.3 Connect the air inlet fitting into the shop air supply hose lock fitting, turn on the air valve (40) to let the pump work until serrated saddle (5) nears workpiece, then turn off the air valve. When air source is unavailable, pump the jack handle (48) until serrated saddle nears workpiece.
- 5.4 Align workpiece and ram to ensure center-loading.
- 5.5 Turn on the air valve (or pump the handle) to apply load onto the workpiece.
- 5.6 When work is done, turn off the air valve (or stop pumping handle), slowly and carefully remove load from workpiece by turning the release valve counterclockwise in small increments.
- 5.7 Once ram has fully retracted, remove workpiece from the press bed frame.
- 5.8 Disconnect the air inlet fitting from the air source.

6. MAINTENANCE

- 6.1 Clean the outside of the press with dry, clean and soft cloth and periodically lubricate the joints and all moving parts with a light oil as needed.
- 6.2 When not in use, store the press in a dry location with ram and piston fully retracted.
- 6.3 When press efficiency drops, purge away air from hydraulic system as described in 4.2.
- 6.4 Check the hydraulic oil level: remove the oil filler nut (55) on the top of the reservoir, if the oil is not adequate, fill with high quality hydraulic jack oil as necessary, then replace the oil filler nut, purge away air from the hydraulic system as described in 4.2.

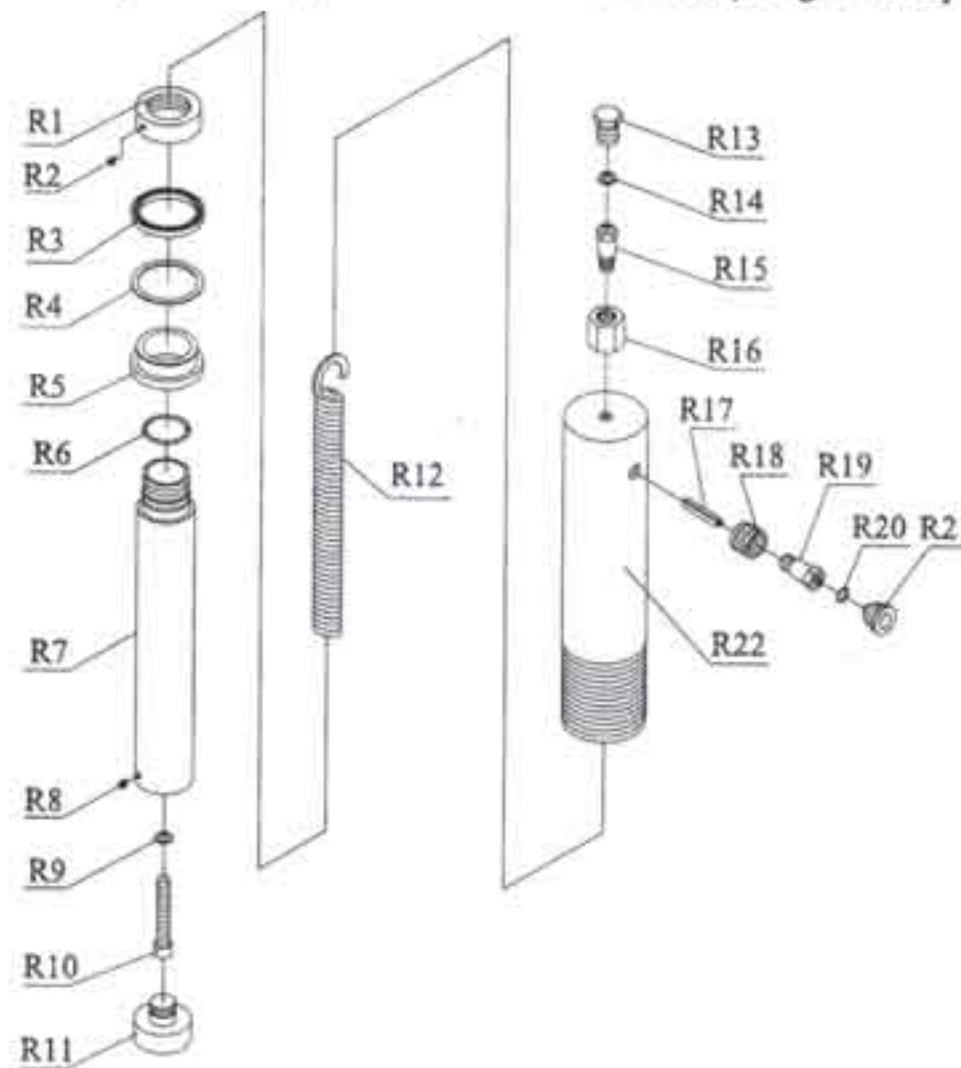

RAM PARTS LIST

Part No.	Description	Qty	Part No.	Description	Qty
R1	Nut	1	R12	Spring	1
R2	Screw M6x6	1	R13	Screw	1
R3	Sealing ring	1	R14	Nylon ring	1
R4	Ring	1	R15	Gauge coupler	1
R5	Bushing	1	R16	Gauge connection nut	1
R6	O-ring	1	R17	Pin	1
R7	Ram	1	R18	Connection nut	1
R8	Screw M6x10	1	R19	Coupler	1
R9	Sealing washer	1	R20	O-ring	1
R10	Bolt M10	1	R21	Dust cap	1
R11	Toe	1	R22	Cylinder	1

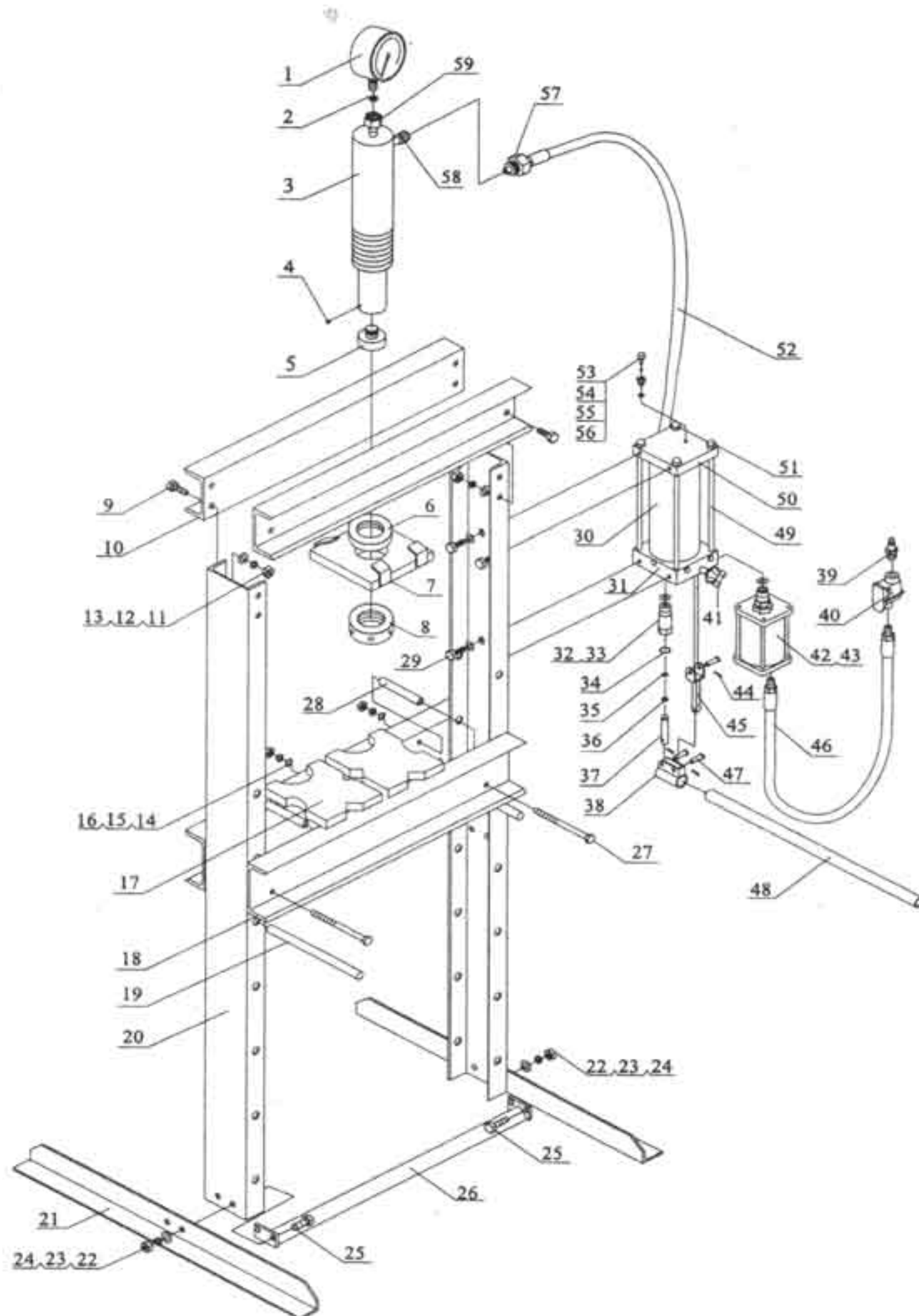

PARTS LIST

Part No.	Description	Qty	Part No.	Description	Qty	Part No.	Description	Qty
1	Pressure gauge	1	21	Base section	2	41	Release valve	1
2	Nylon ring	1	22	Washer Ø12	4	42	Ring	1
3	Ram assy	1	23	Lock washer Ø12	4	43	Air motor	1
4	Lock nut M6	1	24	Nut M12	4	44	R-pin	3
5	Serrated saddle	1	25	Bolt M12x30	4	45	Tie rod	1
6	Upper round nut	1	26	Lower cross member	1	46	Air hose	1
7	Under plate	1	27	Bolt M10x130	4	47	Pin	3
8	Under round nut	1	28	Bushing	4	48	Jack handle	1
9	Bolt M16x35	8	29	Bolt M10x15	4	49	Bolt	1
10	Upper crossbeam	2	30	Reservoir	1	50	Plate	1
11	Nut M16	8	31	Pump assy	1	51	Nut M10	4
12	Lock washer Ø16	8	32	Ring	1	52	Hydraulic hose	1
13	Washer Ø16	8	33	Small ram	1	53	Screw	1
14	Washer Ø10	8	34	Ring	1	54	Sealing ring	1
15	Lock washer Ø10	4	35	O-Ring	1	55	Oil filler nut	1
16	Nut M10	4	36	Nylon ring	1	56	Nylon ring	1
17	Heel block	2	37	Pump core	1	57	Hose fitting	1
18	Press bed frame	2	38	Handle bracket	1	58	Connection nut	1
19	Bed frame pin	2	39	Air inlet fitting	1	59	Gauge connection nut	1
20	Post	2	40	Air valve	1			